

THIS DRAWING IS UNPUBLISHED. RELEASED FOR PUBLICATION  
 © COPYRIGHT - By - ALL RIGHTS RESERVED.

LOC	DIST	REVISIONS					
		P	LTR	DESCRIPTION	DATE	DWN	APVD
G	14		H1	REVISED PER ECO-11-004917	11MAR11	RK	HMR

PART NO	PACKAGE TYPE	QTY
8-32060-1	LOOSE PIECE, BOX	100

1 MATERIAL: BODY & SLEEVE - COPPER PER ASTM B152  
 TIN PLATE PER ASTM B545  
 INSULATION - NYLON, COLOR- BLUE

2 TONGUE MATERIAL THK IS .031±.002

3 FOR .115 TO .170 WIRE INSULATION DIA.

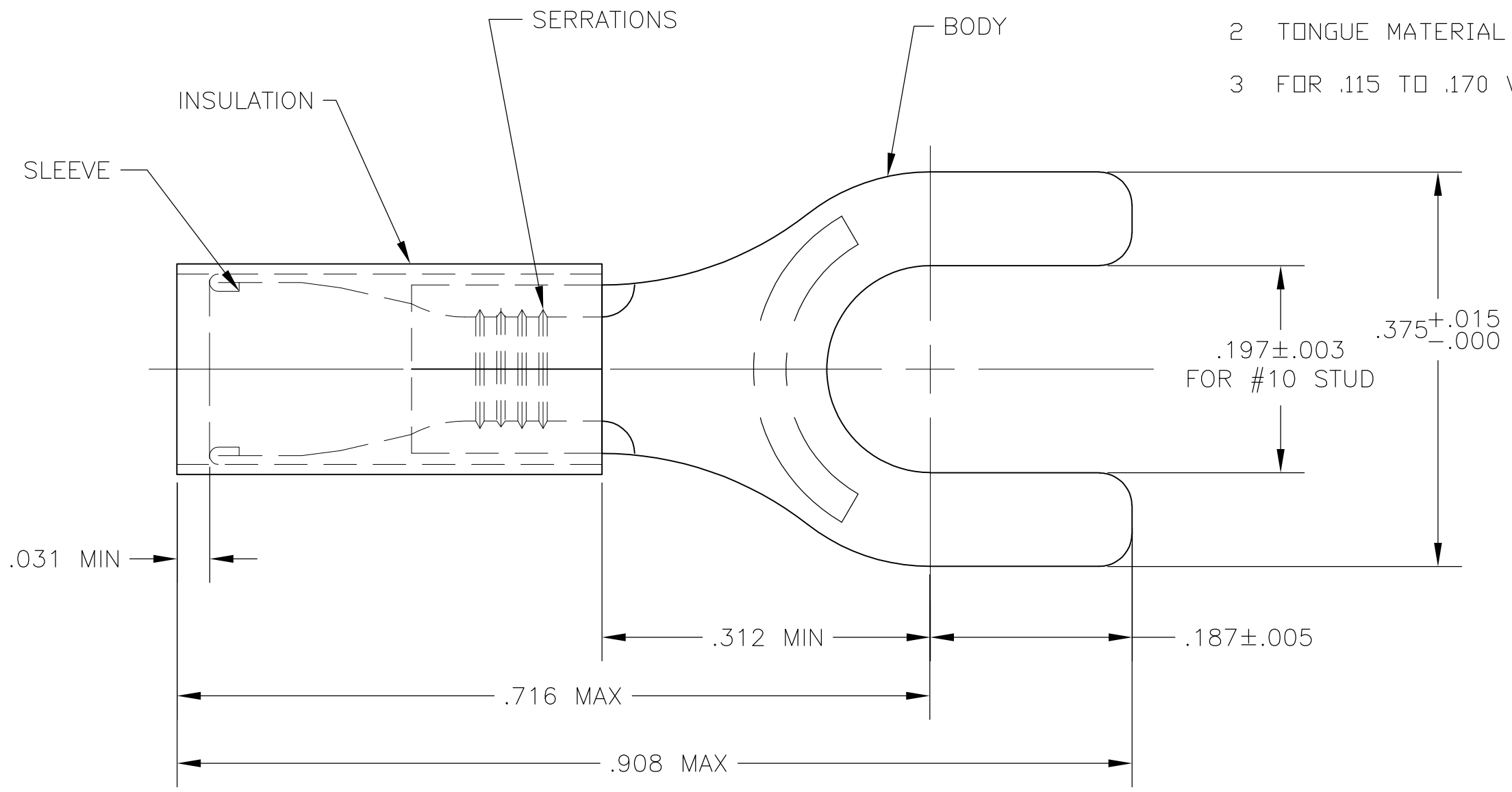

1	32060 ON TAPE	2-32060-1
1	WIRE TERMINAL	32060
QTY	DESCRIPTION	PART NO

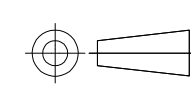
THIS DRAWING IS A CONTROLLED DOCUMENT.		DWN jr_ruth 10NOV04	 TE Connectivity NAME WIRE TERMINAL, PIDG - SPADE, WIRE SIZE : 16-14			
DIMENSIONS: INCHES		CHK T MICHELUTTI 10NOV04				
		APVD T MICHELUTTI 10NOV04				
TOLERANCES UNLESS OTHERWISE SPECIFIED: 0 PLC ± - 1 PLC ± - 2 PLC ± - 3 PLC ± .008 4 PLC ± - ANGLES ± 5°		PRODUCT SPEC - APPLICATION SPEC -				
MATERIAL	FINISH	WEIGHT	SIZE	CAGE CODE	DRAWING NO	RESTRICTED TO
1	1	-	A3	00779	C-32060	-
CUSTOMER DRAWING			SCALE	SHEET	REV	
			8:1	1 OF 1	H1	

单击下面可查看定价，库存，交付和生命周期等信息

[>>TE Connectivity\(泰科\)](#)