

REVISIONS					
P	LTR	DESCRIPTION	DATE	DWN	APVD
A1		ECR-20-004655	29SEP2020	RK	SBH

LV-2

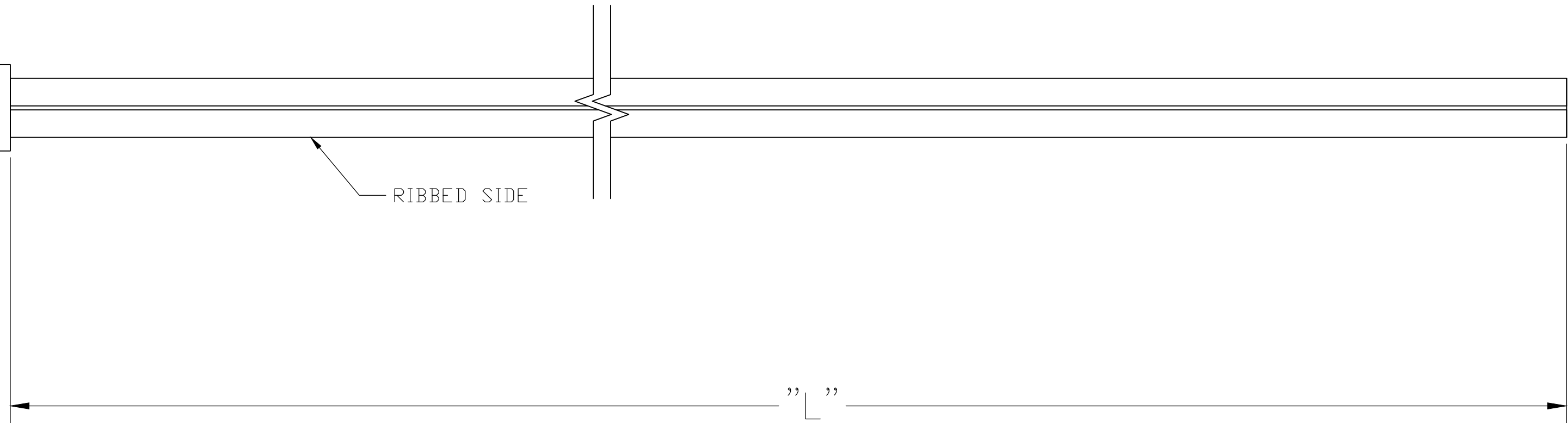
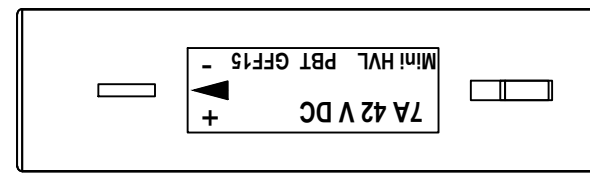
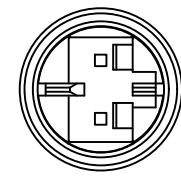

1. PACKAGING ACC. TO TE SPEC.107-18032
BUNDLE EVERY 25 ASSEMBLIES WITH A RUBBER BAND
2. ELECTRICAL TEST CONTAINING "SHORT CIRCUIT TEST, CONTINUITY AND ACCURATE CAVITY ASSIGNMENT TEST" ACC. TO TE-SPEC.108-18857, SUBSECTION 3.1.1

③ WIRING SCHEDULE AS SHOWN

WIRING SCHEDULE		
OUTLET		SIDE
1	+	RIBBED
2	-	SMOOTH

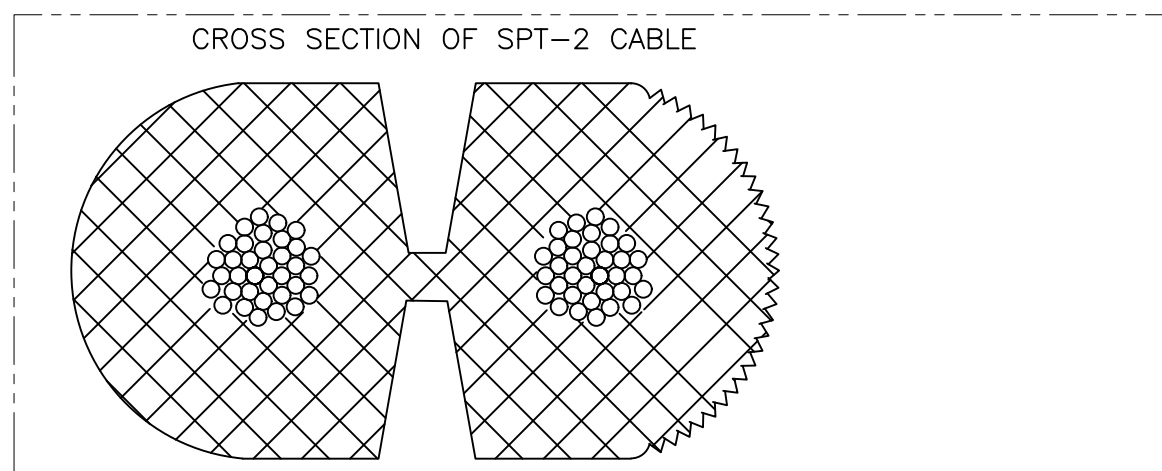

OBSOLETE	16.0 FT	±3.84	2181198-8
	14.0 FT	±3.36	2181198-7
	12.0 FT	±2.88	2181198-6
	10.0 FT	±2.4	2181198-5
OBSOLETE	8.0 FT	±1.92	2181198-4
	6.0 FT	±1.44	2181198-3
	4.0 FT	±.96	2181198-2
	2.0 FT	±.48	2181198-1
	"L"	TOLERANCES [INCHES]	TE P/N

THIS DRAWING IS A CONTROLLED DOCUMENT.		DWN E.C. CLAYBAUGH 16/JUN/11		
DIMENSIONS: INCHES		CHK P. BECKER 13/JUL/11		
TOLERANCES UNLESS OTHERWISE SPECIFIED:		APVD P. BECKER 01/AUG/11	NAME CABLE ASSY, NECTOR, LV-2, OUTLET - PIGTAIL	
0 PLC ± -		PRODUCT SPEC	-	
1 PLC ± -		APPLICATION SPEC	-	
2 PLC ± -		WEIGHT	-	
3 PLC ± -		MATERIAL	-	
4 PLC ± -		FINISH	-	
ANGLES ± -		CUSTOMER DRAWING	-	
SIZE		CAGE CODE	DRAWING NO	RESTRICTED TO
A2		00779	C-2181198	-
SCALE		SHEET	REV	
N.T.S.		1 OF 1	A1	

单击下面可查看定价，库存，交付和生命周期等信息

[>>TE Connectivity\(泰科\)](#)