

LOC		DIST		REVISIONS			
P	LTR	DESCRIPTION	DATE	DMN	APVD		
G		REV PER ECO-12-016000	4-9-09	RM	RL		

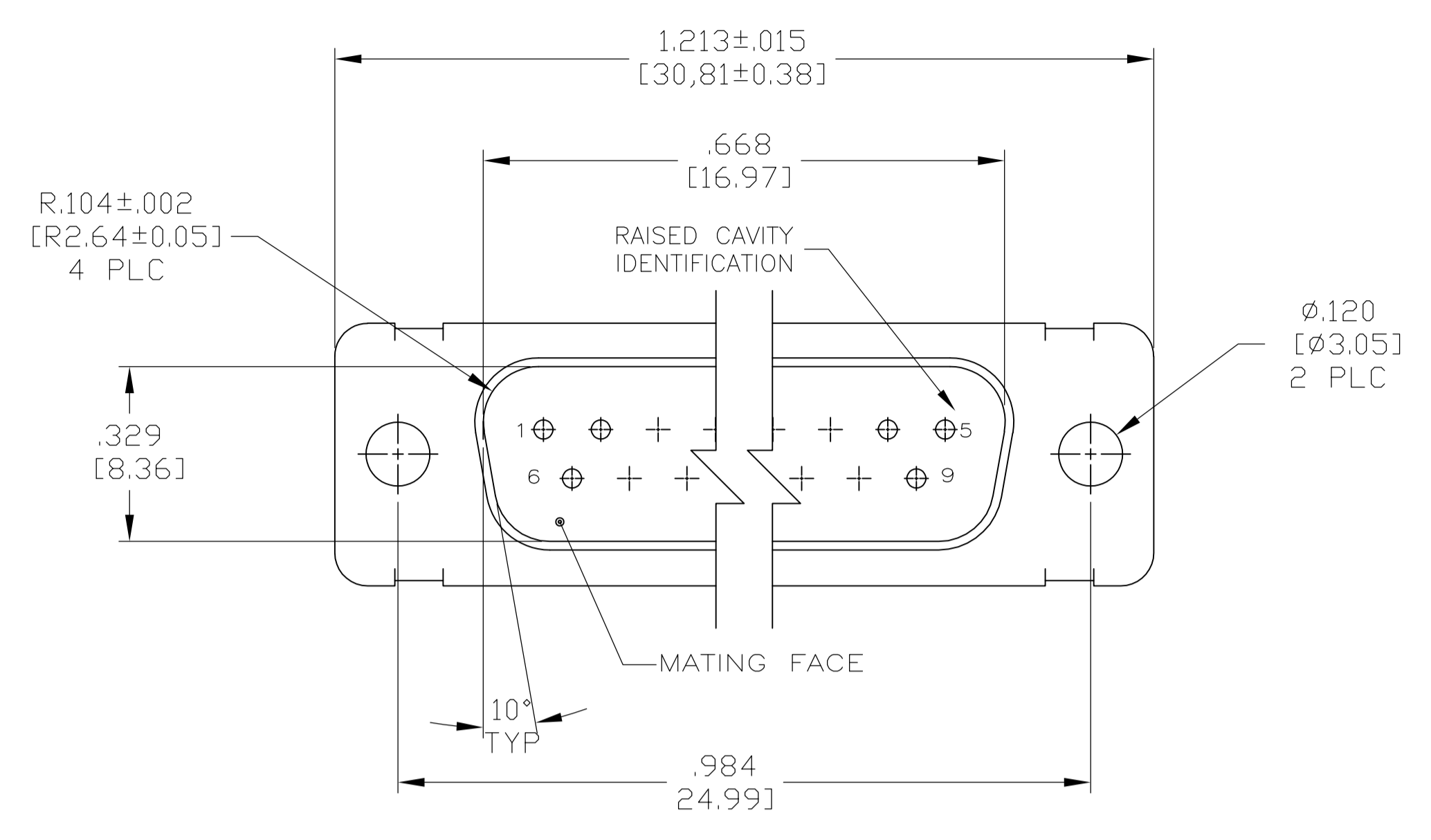

- THIS CONNECTOR ASSEMBLY IS SUPPLIED WITH Be Cu CONTACT RETENTION CLIPS INSTALLED IN THE INSERT ASSEMBLY.
  - THIS CONNECTOR ASSEMBLY MATES WITH ANY PLUG CONNECTOR WITH THE SAME INSERT ARRANGEMENT AND DIMENSIONAL REQUIREMENTS PER MIL-C-24308.
  - MARKED WITH .047 [1.19]-.062 [1.57] HIGH CHARACTERS. FAR SIDE REFERS TO THE WIDE SIDE OF THE KEYSTONE. NEAR SIDE REFERS TO THE NARROW SIDE OF THE KEYSTONE.
  - MAXIMUM WIRE INSULATION TO BE USED WITH THIS CONNECTOR ASSEMBLY IS .054 [1.37] DIAMETER.
- 3 SPECIAL REQUIREMENTS PER BOEING 1A01 DOCUMENT.  
6 BUILT TO ORDER, NO INVENTORY OF THIS PART NUMBER IS TO BE KEPT. SINGLE LOT DATE CODE REQUIRED.

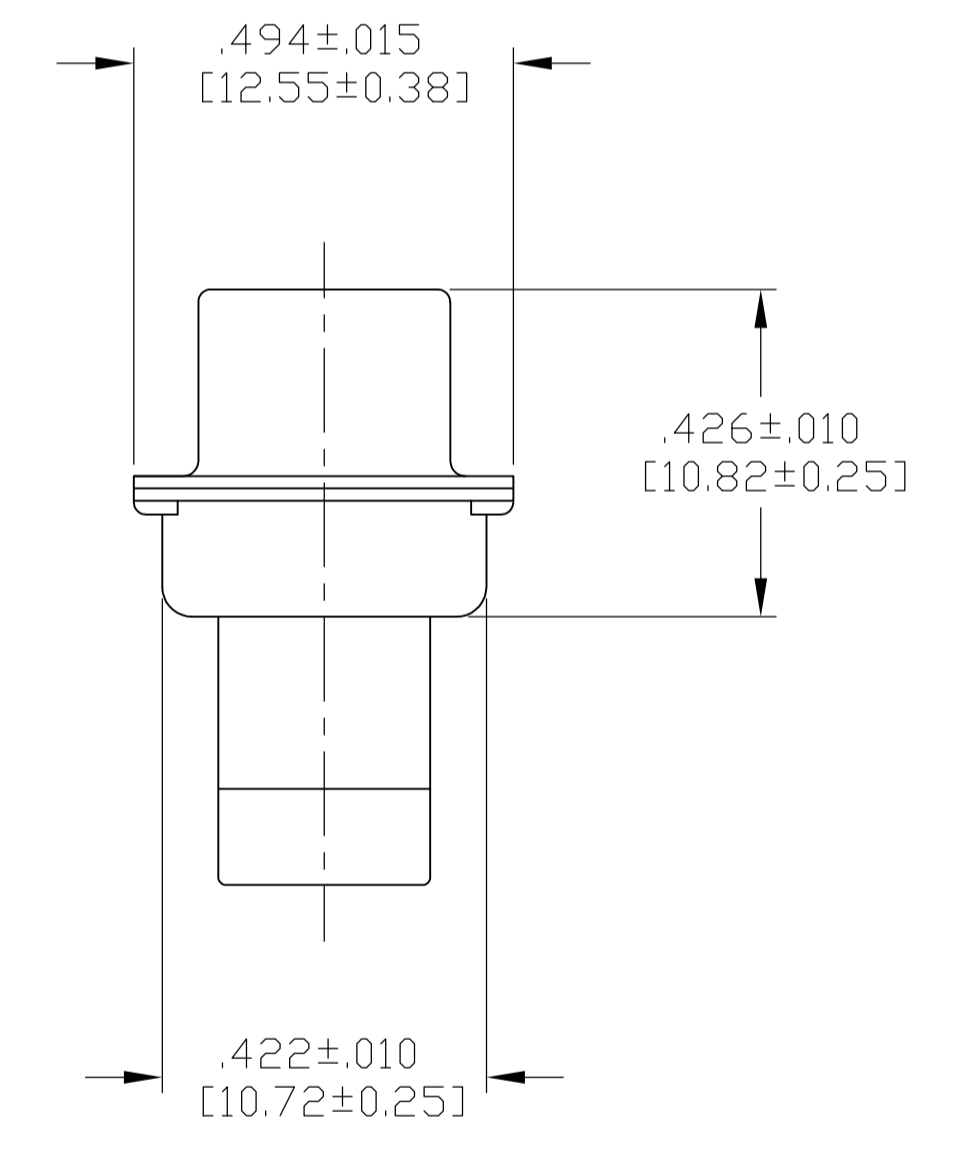
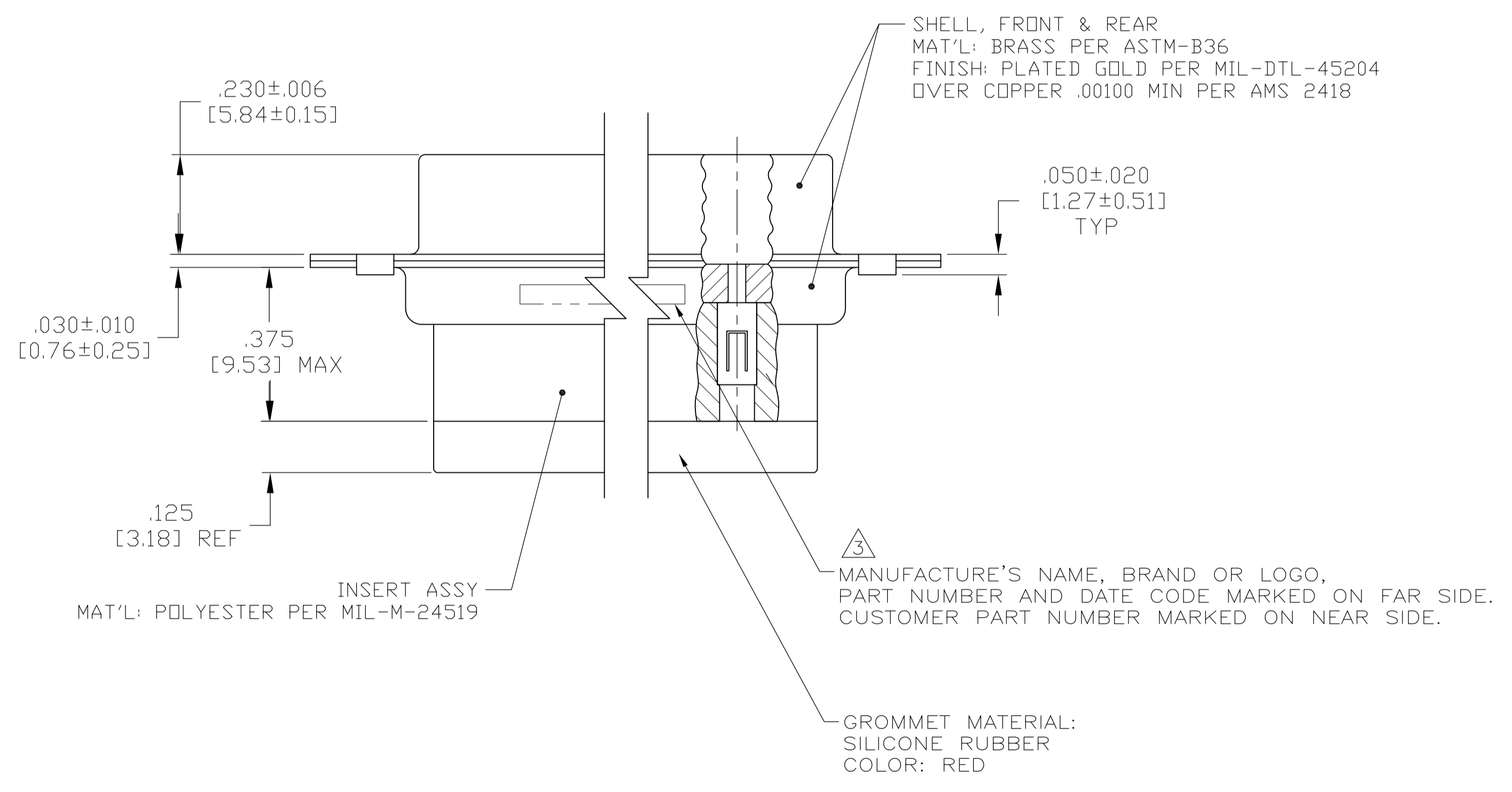

OBsolete

REMARKS	CUSTOMER MARKING	PART NUMBER
<span style="border: 1px solid black; padding: 2px;">6</span> <span style="border: 1px solid black; padding: 2px;">7</span>	1A01-026PHW	1-211638-1
<span style="border: 1px solid black; padding: 2px;">7</span>	A70323-12013-026	211638-8
--	---	211638-4
<span style="border: 1px solid black; padding: 2px;">7</span>	2A014-031V-001	211638-2
<span style="border: 1px solid black; padding: 2px;">6</span> <span style="border: 1px solid black; padding: 2px;">7</span>	1A01-026PHA	211638-1

THIS DRAWING IS A CONTROLLED DOCUMENT.		DIN C.C.THOMAS 4-9-09		Tyco Electronics Corporation Harrisburg, PA 17105-3608																															
DIMENSIONS: INCHES [mm]		TOLERANCES UNLESS OTHERWISE SPECIFIED:		NAME																															
<table border="1"> <tr><td>0 PLC</td><td>±</td><td>--</td></tr> <tr><td>1 PLC</td><td>±</td><td>--</td></tr> <tr><td>2 PLC</td><td>±</td><td>--</td></tr> <tr><td>3 PLC</td><td>±</td><td>.005 [0.13]</td></tr> <tr><td>4 PLC</td><td>±</td><td>--</td></tr> <tr><td>ANGLES</td><td>±</td><td>--</td></tr> </table>		0 PLC	±	--	1 PLC	±	--	2 PLC	±	--	3 PLC	±	.005 [0.13]	4 PLC	±	--	ANGLES	±	--	<table border="1"> <tr><td>APVD</td><td>R</td><td>LEASE</td><td>4-9-09</td></tr> <tr><td>PRODUCT SPEC</td><td></td><td></td><td></td></tr> <tr><td>APPLICATION SPEC</td><td></td><td></td><td></td></tr> </table>		APVD	R	LEASE	4-9-09	PRODUCT SPEC				APPLICATION SPEC				PLUG ASSY, AMPLIMITE, 9 POSN, SIZE 1, SERIES 109 WITH GROMMET	
0 PLC	±	--																																	
1 PLC	±	--																																	
2 PLC	±	--																																	
3 PLC	±	.005 [0.13]																																	
4 PLC	±	--																																	
ANGLES	±	--																																	
APVD	R	LEASE	4-9-09																																
PRODUCT SPEC																																			
APPLICATION SPEC																																			
MATERIAL SEE CALLOUTS		FINISH SEE CALLOUTS		RESTRICTED TO																															
CUSTOMER DRAWING		SCALE 4:1		SHEET 1 OF 1 REV G																															

单击下面可查看定价，库存，交付和生命周期等信息

[>>TE Connectivity\(泰科\)](#)