

- 1 CAVITY IDENTIFICATION ON FRONT AND REAR FACE.
- 2 MATERIALS:
 HOUSING: NYLON, UL94 V-0, BLACK
 CONTACT SPRING: STAINLESS STEEL
 CONTACT BODY AND POST: BRASS
 THREADED INSERTS: BRASS
- 3 FINISHES:
 CONTACT BODY: .00076 [.000030] MIN GOLD FOR A LENGTH OF 5.08 [.200] MIN FROM MATING END OF PIN GOLD FLASH ON REMAINDER OF CONTACT. BOTH OVER .00127 [.000050] MIN NICKEL
 CONTACT POST: .00254 [.000100] MIN TIN OVER .00127 [.000050] MIN NICKEL.

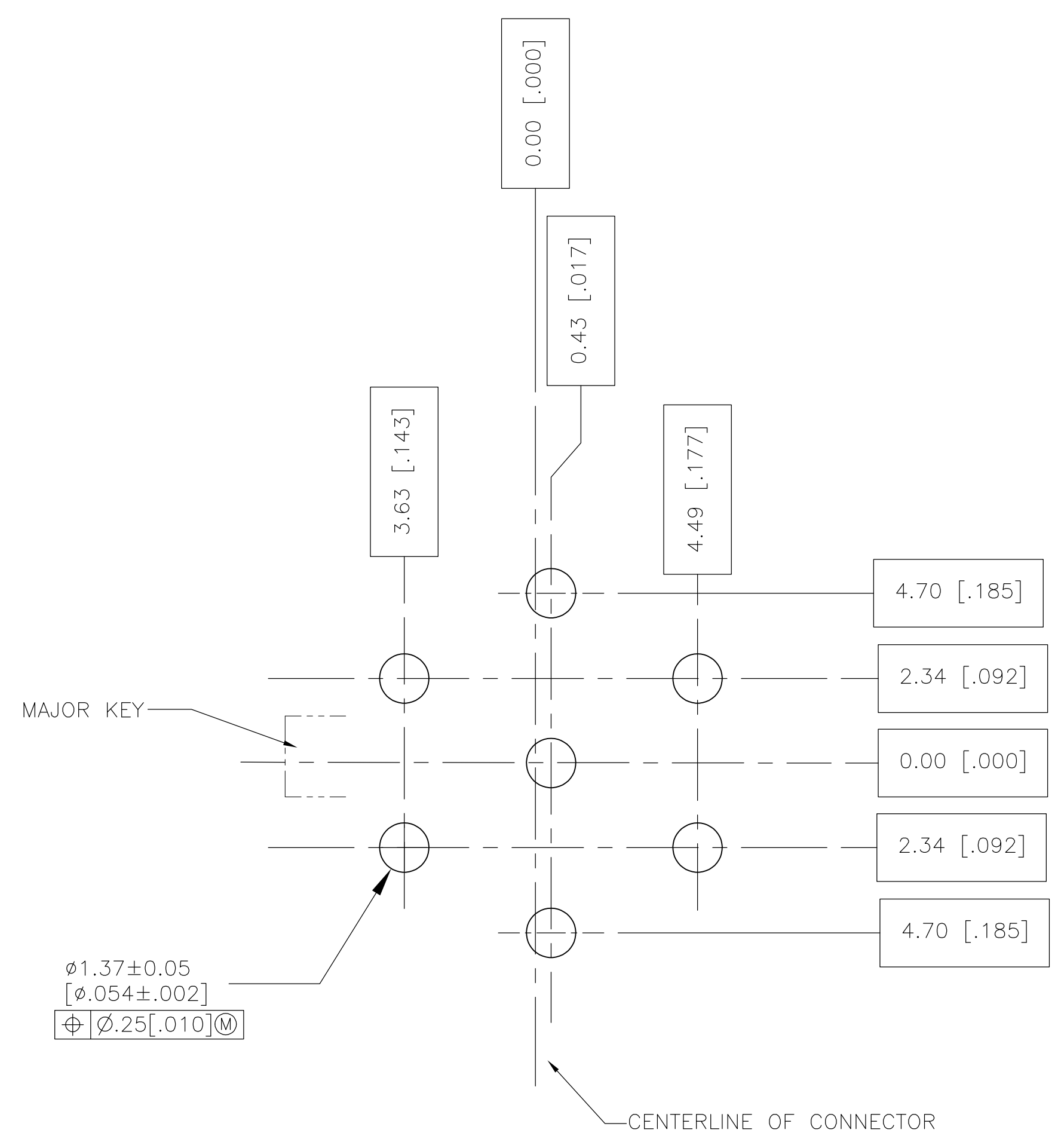
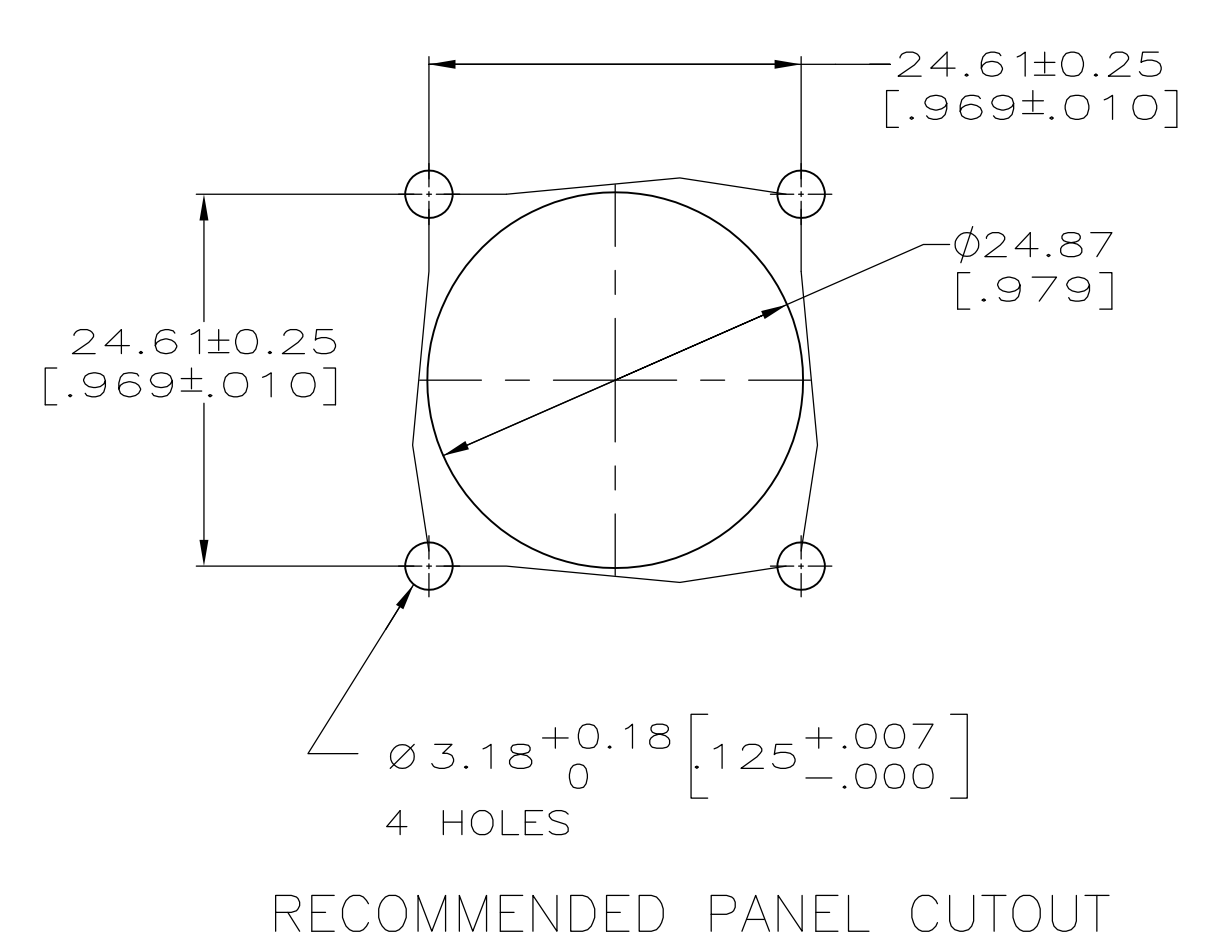
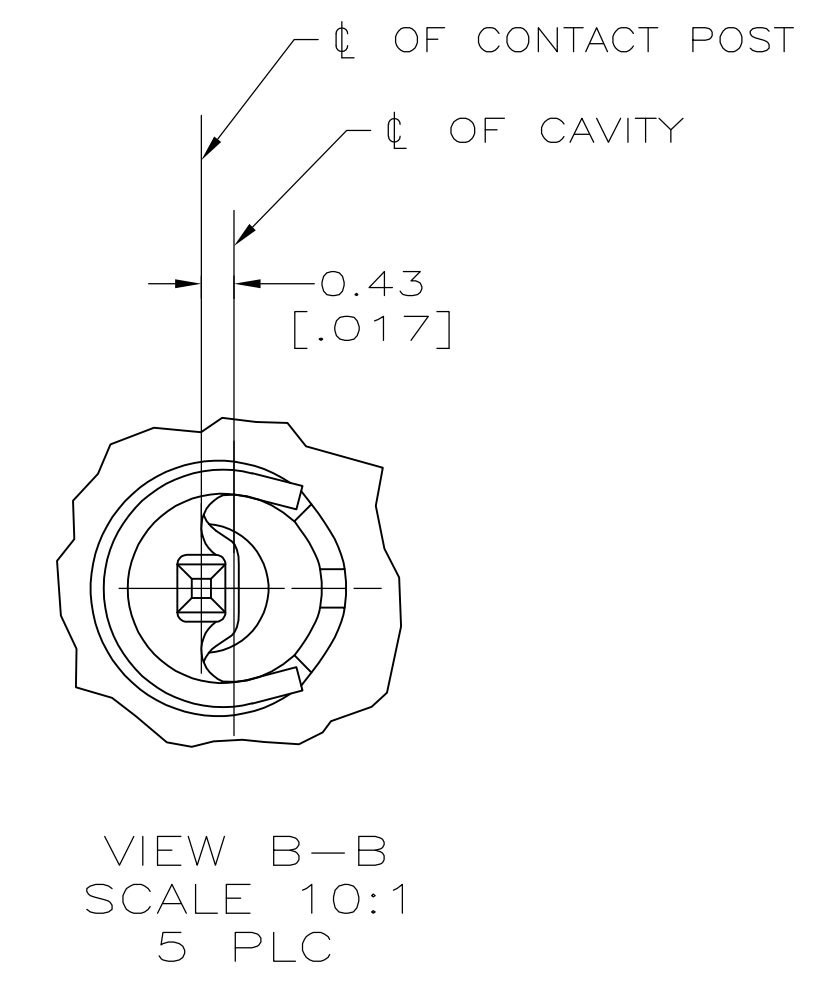

2267121-1
 PART NUMBER

THIS DRAWING IS A CONTROLLED DOCUMENT.		DIN NAGALAKSHMI_K 30MAY2014		STE TE Connectivity	
DIMENSIONS: mm [INCHES]		TOLERANCES UNLESS OTHERWISE SPECIFIED:		ZITTO, MARK 30MAY2014	
0 PLC ± -		1 PLC ± -		NAME ZITTO, MARK	
2 PLC ± ± 0.13[.005]		3 PLC ± ± -		PRODUCT SPEC 108-10024	
4 PLC ± ± -		ANGLES ± ± -		APPLICATION SPEC 114-10038	
MATERIAL		FINISH		SIZE CAGE CODE DRAWING NO RESTRICTED TO	
2		3		A1 00779 C=2267121 -	
CUSTOMER DRAWING				SCALE 2:1 SHEET 1 OF 1 REV A	

单击下面可查看定价，库存，交付和生命周期等信息

[>>TE Connectivity\(泰科\)](#)