

THIS DRAWING IS UNPUBLISHED.

RELEASED FOR PUBLICATION MAY, 21

ALL RIGHTS RESERVED.

© COPYRIGHT 02 By -

LOC	DIST	REVISIONS					
		P	LTR	DESCRIPTION	DATE	DWN	APVD
J	-	R1		ALTERNATE RESIN UPDATE FOR 1-171370-2	12MAR2020	SE	PKS

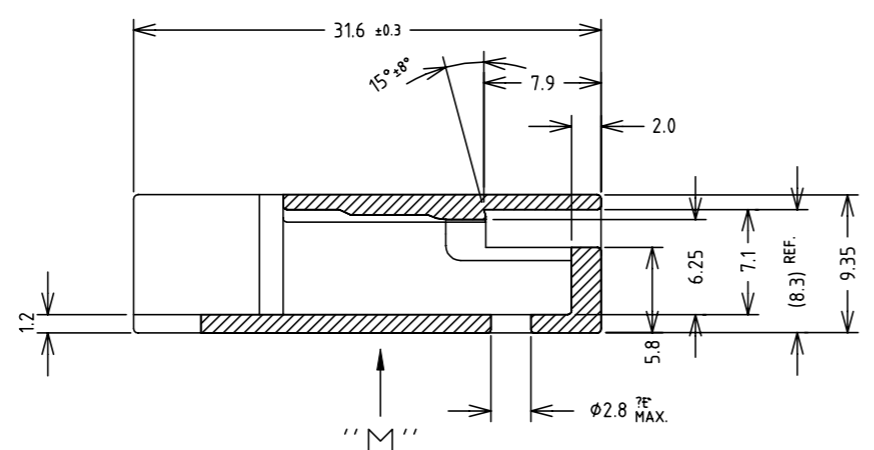
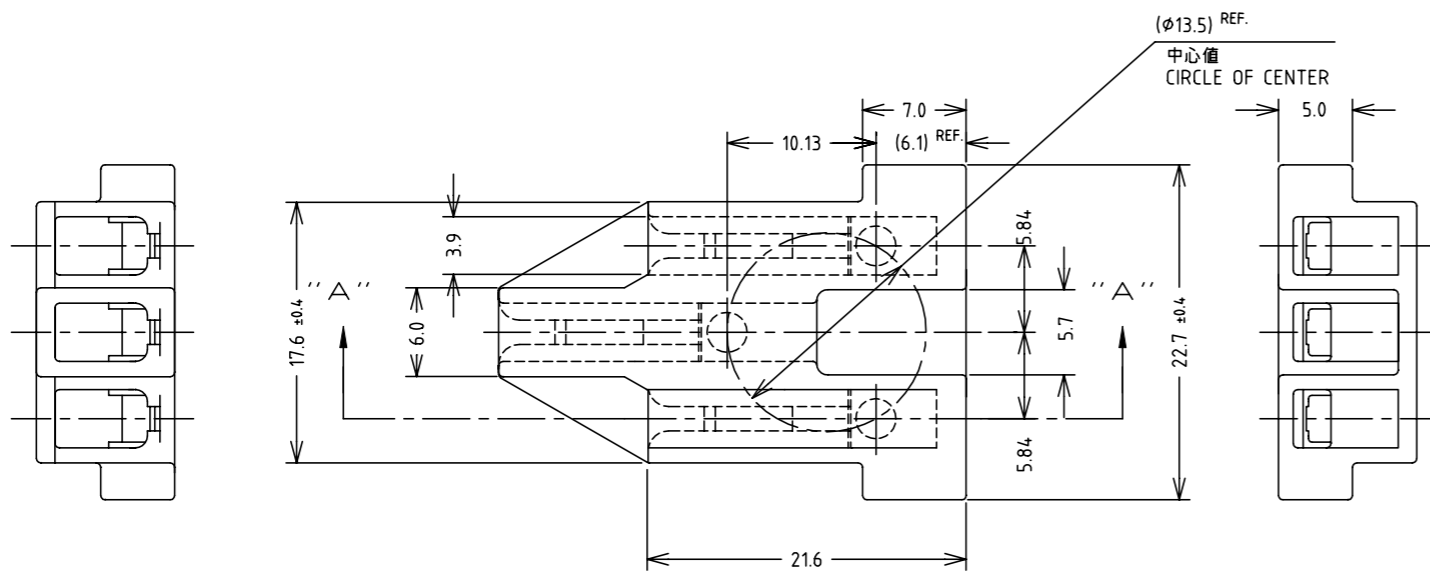

断面 "A" - "A" SECT

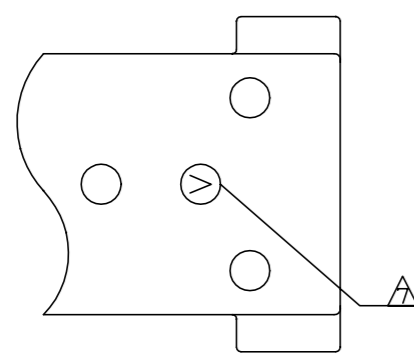

矢視 "M" 1-171370-2 VIEW

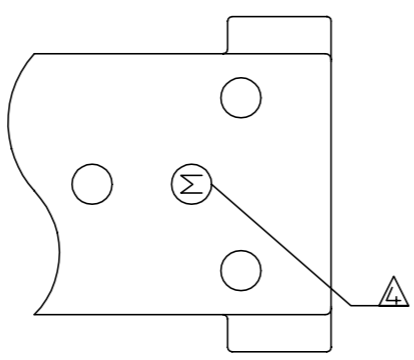

矢視 "M" 1-171370-1 VIEW

- 注記:
- 一般公差 : ±0.2
 - 適用ピン リセプタクル型番 : □ -170063-□ , □ -353937-□ , □ -1123655-□
 - 適用規格番号 : 108-5143 (型番1-171370-1)
- 裏面上I.Dマーク : 型番1-171370-1のみ M 表示 文字の向きは任意とする。
 - ミュールスRタイプ : UL94V-0 , CTI 600V
 - フェノール ノンアンモニア : UL94V-0 , CTI 175 ~ 249V以上
 - 裏面上I.Dマーク : 型番1-171370-2のみ L 表示 文字の向きは任意とする。

- NOTES:
- GENERAL TOLERANCE ±0.2
 - APPLICABLE CONTACT PART No.: □ -170063-□ , □ -353937-□ , □ -1123655-□
 - PRODUCT SPEC No.: 108-5143(1-171370-1)
- I.D MARK ON REAR SIDE : INDICATION M AT PART No.1-171370-1 ONLY. DIRECTION OF CHARACTERS IS FREE.
 - MEWLUS "R" TYPE : UL94V-0 , CTI 600V MIN
 - PHENOLIC NONAMMONIA UL94V-0 , CTI 175 ~ 249V
 - I.D MARK ON REAR SIDE : INDICATION L AT PART No.1-171370-2 ONLY. DIRECTION OF CHARACTERS IS FREE.

1-171370-2	フェノール (PHENOLIC)	黒 (BLACK)
1-171370-1	ミュールス Rタイプ (MEWLUS "R" TYPE)	黒 (BLACK)
型番 (PART No.)	材料 (MATERIAL)	色 (COLOR)

THIS DRAWING IS A CONTROLLED DOCUMENT.		DWN	M.SUZUKI	21MAY2002	STE TE Connectivity
DIMENSIONS: 単位: 耗 mm		CHK	M.SHINDO	21MAY2002	
TOLERANCES UNLESS OTHERWISE SPECIFIED: 一般公差		APVD	M.SHINDO	21MAY2002	NAME 名称 2.3 DIA CLUSTER BLOCK Φ2.3 クラスタブロック
0 PLC ± - 1 PLC ± - 2 PLC ± - 3 PLC ± - 4 PLC ± - ANGLES ± -		PRODUCT SPEC	SEE NOTES 3.		
MATERIAL 材料 SEE TABLE		FINISH 仕上	APPLICATION SPEC 取付適用規格		SIZE
		WEIGHT	DRAWING NO 番号 A300779		CAGE CODE
		CUSTOMER DRAWING	G=171370		RESTRICTED TO
		SCALE 尺度	4:1	SHEET	1 of 3
				REV	R1

THIS DRAWING IS UNPUBLISHED. RELEASED FOR PUBLICATION MAY, 21 .
 © COPYRIGHT 02 By - ALL RIGHTS RESERVED.

LOC	DIST	REVISIONS					
J		P	LTR	DESCRIPTION	DATE	DWN	APVD
		-	-	SEE SHEET 1	-	-	-

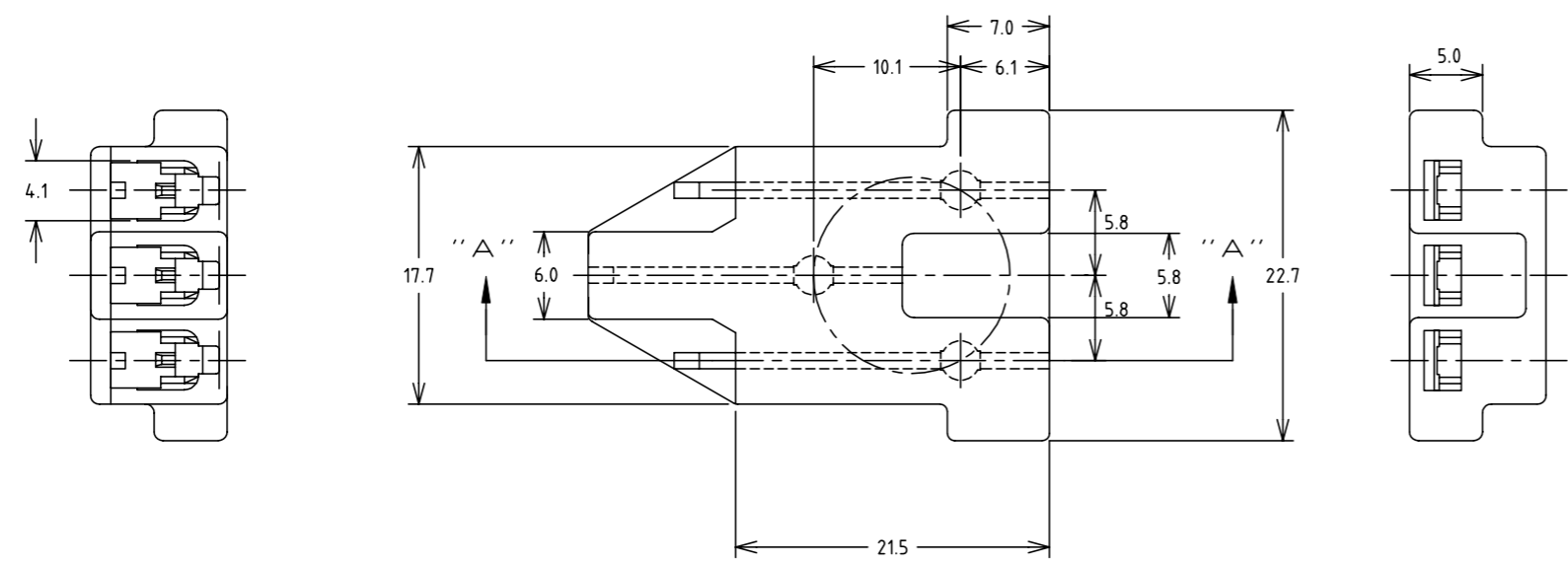

注記:

- 一般公差 : ±0.2
- 適用ピン リセプタクル型番 : □-170063-□, □-353937-□, □-1123655-□
- 適用規格番号: 108-5205(型番171370-3)
108-61239(型番171370-4)
108-5541(型番171370-5)

- △4 PARTS COMPLY WITH GLOW WIRE 750 PER IEC 60335-1.
- △5 MUST BE APPLIED ON THE OUTSIDE OF COMPRESSOR.

NOTES:

- GENERAL TOLERANCE ±0.2
- APPLICABLE CONTACT PART No.:
□-170063-□, □-353937-□, □-1123655-□
- PRODUCT SPEC No.: 108-5205(FOR PART No.171370-3)
108-61239(FOR PART No.171370-4)
108-5541(FOR PART No.171370-5)

- △4 GLOW WIRE 750(IEC 60335-1), CTI 600V(HALOGEN FREE)
- △5 MUST BE APPLIED ON THE OUTSIDE OF COMPRESSOR.

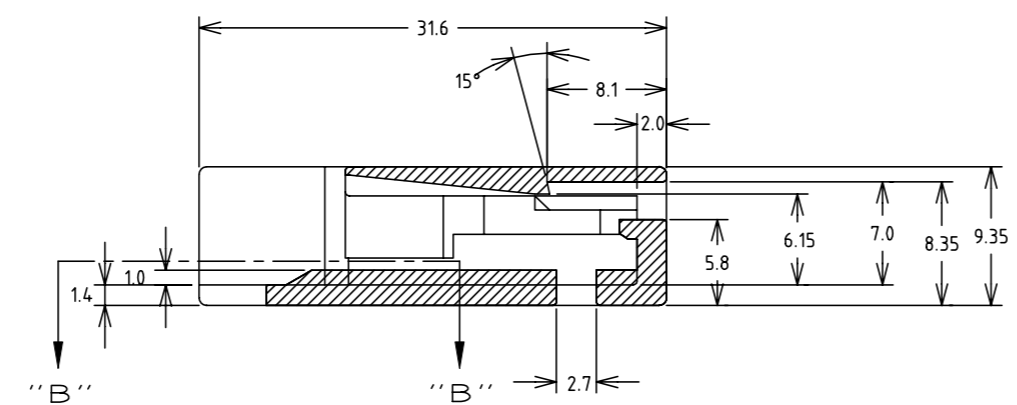

断面 "A" - "A" SECT

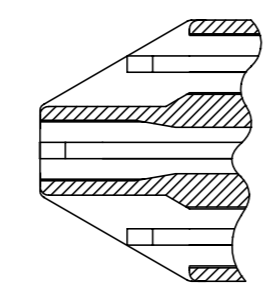

断面 "B" - "B" SECT

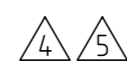

171370-5	PBT ガラス強化 PBT GLASS FILLED(UL94V-0)	灰色 (GRAY)
171370-4	PBT ガラス強化 PBT GLASS FILLED(UL94V-0)	黒 (BLACK)
171370-3	PBT ガラス強化 PBT GLASS FILLED(UL94HB)	自然色 (NATURAL)
型番 (PART No.)	材料 (MATERIAL)	色 (COLOR)

THIS DRAWING IS A CONTROLLED DOCUMENT.		DWN	TE Connectivity			
DIMENSIONS: 単位: 耗 mm		CHK				
TOLERANCES UNLESS OTHERWISE SPECIFIED: 一般公差		APVD	NAME 名称			
0 PLC ± 1 PLC ± 2 PLC ± 3 PLC ± 4 PLC ± ANGLES ±		PRODUCT SPEC 製品規格	2.3 DIA CLUSTER BLOCK			
MATERIAL 材料		APPLICATION SPEC 取付適用規格	Φ2.3 クラスタブロック			
SEE TABLE		WEIGHT	SIZE	CAGE CODE	DRAWING NO 番号	RESTRICTED TO
		CUSTOMER DRAWING	A3	00779	171370	-
		SCALE 尺度	SHEET		REV	
		4:1	2 of 3		R1	

THIS DRAWING IS UNPUBLISHED. RELEASED FOR PUBLICATION MAY, 21 .
 © COPYRIGHT 02 By - ALL RIGHTS RESERVED.

LOC	DIST	REVISIONS 変更					
		P	LTR	DESCRIPTION	DATE	DWN	APVD
J		-	-	SEE SHEET 1	-	-	-

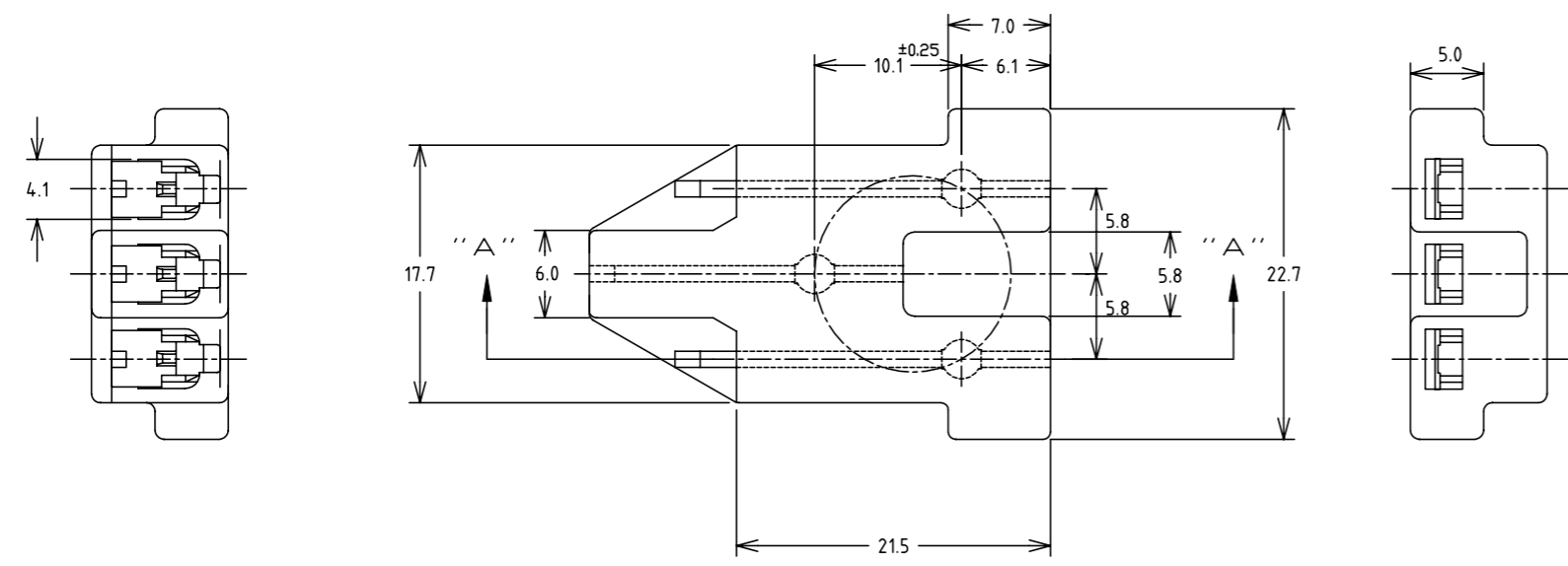

注記:

1. 一般公差 : ±0.2
2. 適用ピン リセプタクル型番 : □-170063-□, □-353937-□, □-1123655-□
3. 適用規格番号: 108-140004 (型番171370-7)
4. PRELIMINARY-NOT FOR PRODUCTION
5. PARTS COMPLY WITH GLOW WIRE REQUIREMENTS DETAILED IN IEC 60335-1

NOTES:

1. GENERAL TOLERANCE ±0.2
2. APPLICABLE CONTACT PART No. : □-170063-□, □-353937-□, □-1123655-□
3. PRODUCT SPEC No.: 108-140004 (FOR PART No.171370-7)
4. PRELIMINARY-NOT FOR PRODUCTION
5. PARTS COMPLY WITH GLOW WIRE REQUIREMENTS DETAILED IN IEC 60335-1
6. PRELIMINARY PART

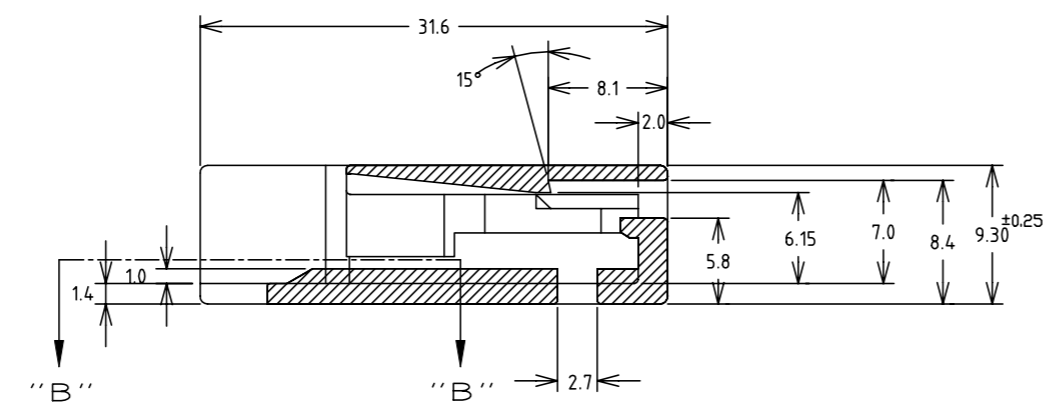

断面 "A" - "A" SECT

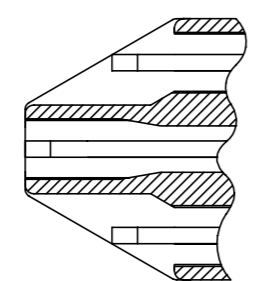

断面 "B" - "B" SECT

△6	171370-8	PPS (UL94V-0)	(NATURAL)
△5	171370-6	PA 6 GLASS FILLED	自然色 (NATURAL)
	171370-7	液晶ポリマー (UL94V-0) LCP (UL94V-0)	自然色 (NATURAL)
	型番 (PART No.)	材料 (MATERIAL)	色 (COLOR)

THIS DRAWING IS A CONTROLLED DOCUMENT.		DWN	STE TE Connectivity		
DIMENSIONS: 単位: 耗 mm		CHK			
TOLERANCES UNLESS OTHERWISE SPECIFIED: 一般公差		APVD	NAME 名称		
0 PLC ±		PRODUCT SPEC 製品規格	2.3 DIA CLUSTER BLOCK		
1 PLC ±		APPLICATION SPEC 取付適用規格	Φ2.3 クラスタブロック		
2 PLC ±		SEE NOTE 3	SIZE	CAGE CODE	DRAWING NO 番号
3 PLC ±			A3	00779	C=171370
4 PLC ±			RESTRICTED TO		
ANGLES ±		WEIGHT	-		
MATERIAL 材料		CUSTOMER DRAWING		SCALE 尺度	SHEET
SEE TABLE				4:1	3 of 3
				REV	R1

单击下面可查看定价，库存，交付和生命周期等信息

[>>TE Connectivity\(泰科\)](#)