

REVISIONS			
LTR	DESCRIPTION	DATE	APPROVED
B	REVISED PER ECN# T-21394	4/10/97	Z. TEMAN
C	REVISED PER ECN# T-21730	9/19/97	Z. TEMAN

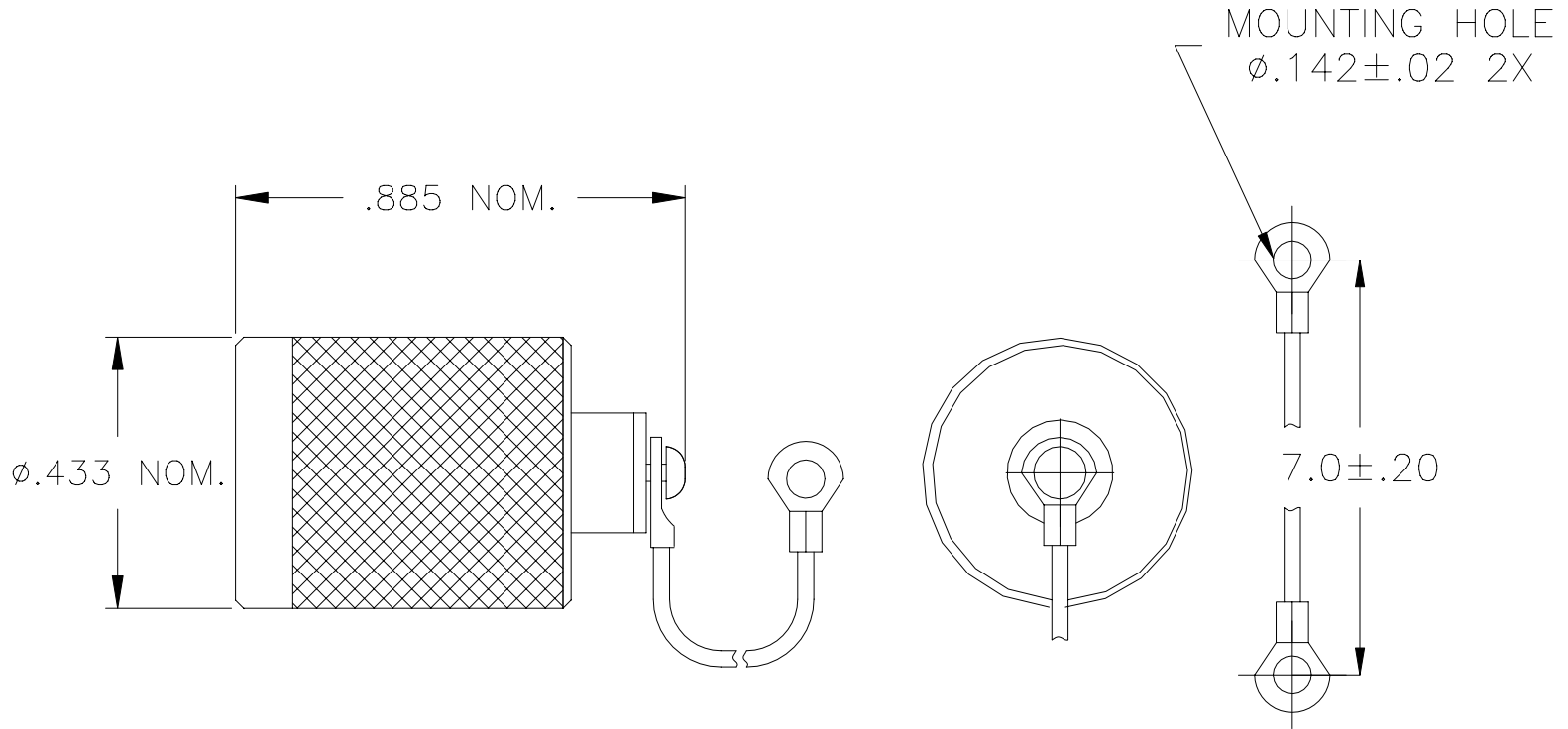

NOTE:  
THIS DUST CAP IS TO BE USED ON A 5/16-32 THREADED INTERFACE CONNECTOR.

1.0 MATERIALS AND FINISHES

1.1 DUST CAP COUPLING NUT: BRASS ALLOY 360, HALF HARD PER ASTM B 16.  
TIN PLATED PER MIL-T-10727, OVER NICKEL PER QQ-N-290.

1.2 INTERFACIAL SEAL: SILICONE RUBBER

1.3 SCREW AND LANYARD: STAINLESS STEEL, PASSIVATED PER QQ-P-35.

If this document is printed it becomes uncontrolled.  
Check for the latest revision.

## SPECIFICATION CONTROL DRAWING

UNLESS OTHERWISE SPECIFIED DIMENSIONS ARE IN INCHES. METRIC DIMENSIONS ARE IN BRACKETS.  DECIMALS .XXX ± — [ — mm ] .XX ± — [ — mm ] ANGLES .X ± — WEIGHT — lbs [ — g ]	DRAWN	ZET	2/20/97		Tyco Electronics Corporation 300 Constitution Drive Menlo Park, CA. 94025 U.S.A.		
	CHECKED						
	APPROVED			TITLE			
	APPROVED	P.DUTTON			DUST CAP, THREADED, COUPLED,		
CAD NAME							
T21730							
THIRD ANGLE PROJECTION				SIZE	CODE IDENT. NO.	DWG. NO.	REV
				A	n6090	D-600-0083	C
				Downloaded From <a href="http://Oneyac.com">Oneyac.com</a>		SHEET 1 OF 1	

单击下面可查看定价，库存，交付和生命周期等信息

[>>TE Connectivity\(泰科\)](#)