

THIS DRAWING IS UNPUBLISHED.
 QUESTO DISEGNO NON DEVE ESSERE DIVULGATO O RIPRODOTTO
 © COPYRIGHT 19 BY - TE CONNECTIVITY

RELEASED FOR PUBLICATION
 E' CONSENTITA LA DIVULGAZIONE
 ALL RIGHTS RESERVED.
 TUTTI I DIRITTI SONO RISERVATI

20

REVISIONS
REVISIONI

P	LTR REV	DESCRIPTION DESCRIZIONE	DATE DATA	DWN DIS.	APVD APP.
	A2	ECO-16-016613	17NOV2016	M.P.	M.G.

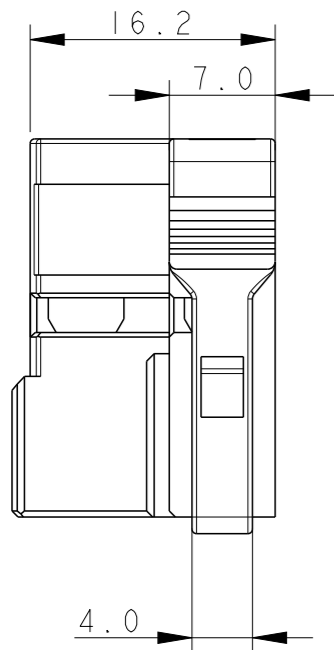

HOUSING
(BLOCCHETTO)

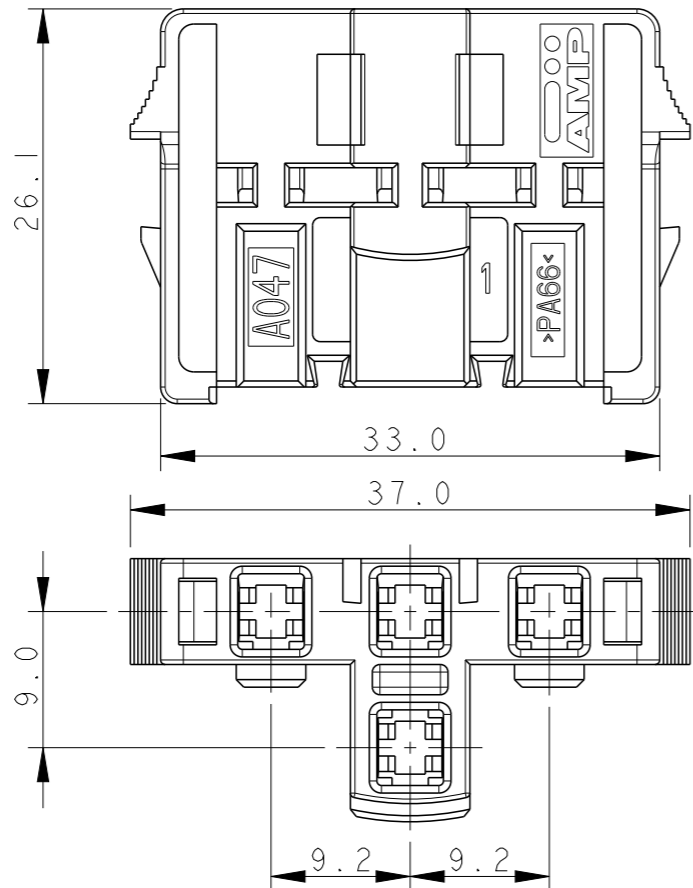

SECONDARY LOCK
(AGGANCIAMENTO SECONDARIO)

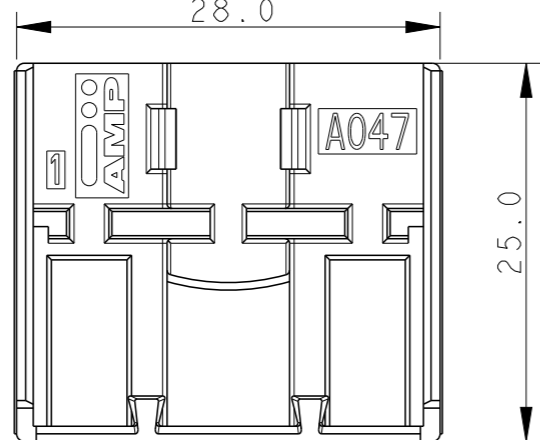
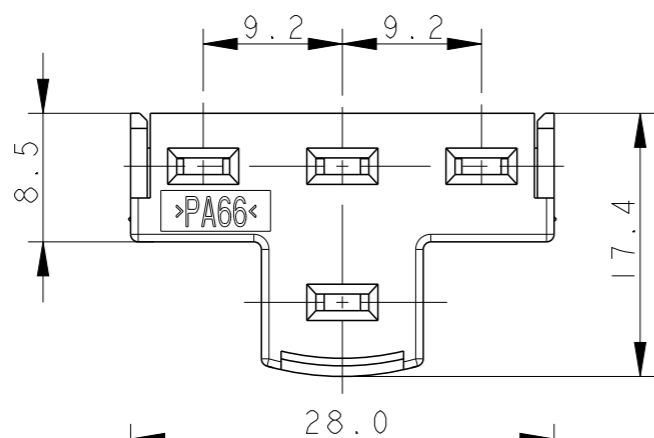

- 1) HOUSING AND SECONDARY LOCK ARE SUPPLIED UNASSEMBLED WITH EQUIVALENT NUMBER OF PIECES FOR EACH COMPONENT IN A BOX (BLOCCHETTO PORTA-FEMMINE E AGGANCIAMENTO SECONDARIO FORNITI NON ASSEMBLATI IN KIT CON PARI NUMERO DI PEZZI PER SCATOLA)
- 2) N°4 CAVITIES FOR JPT CONTACTS P/N 965999-2 & 964284-2 (N°4 CAVITA' PER CONTATTI JPT P/N 965999-2 E 964284-2)
- 3) FOR COUNTERPART SEE SHEET 2 OF 2 (PER CONTROPARTE VEDERE FOGLIO 2 DI 2)
- 4) FOR NOTES n° 5-6-7 SEE SHEET 2 of 2 (PER NOTE n° 5-6-7 VEDI FOGLIO 2 of 2)

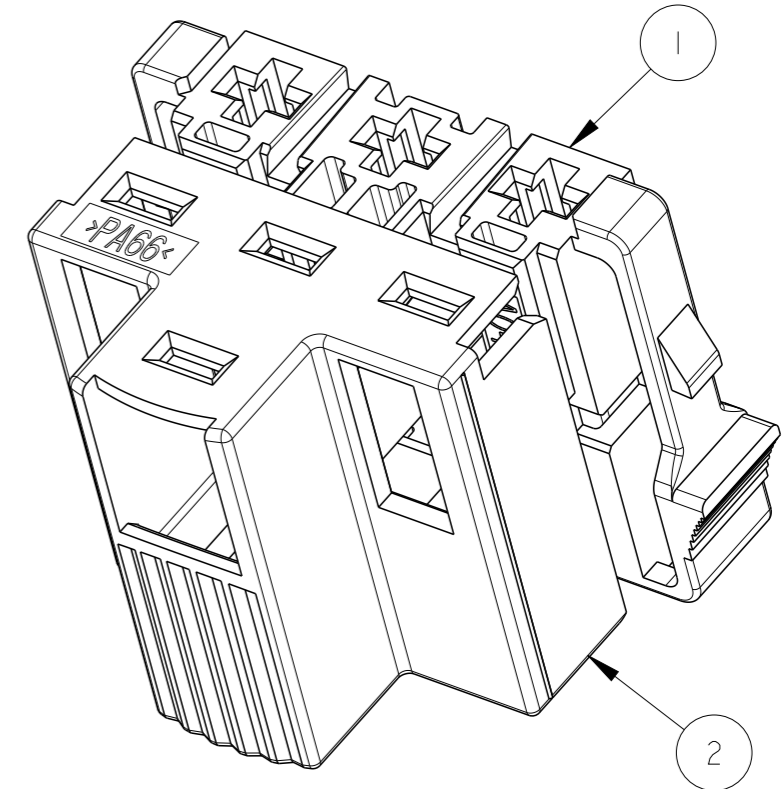
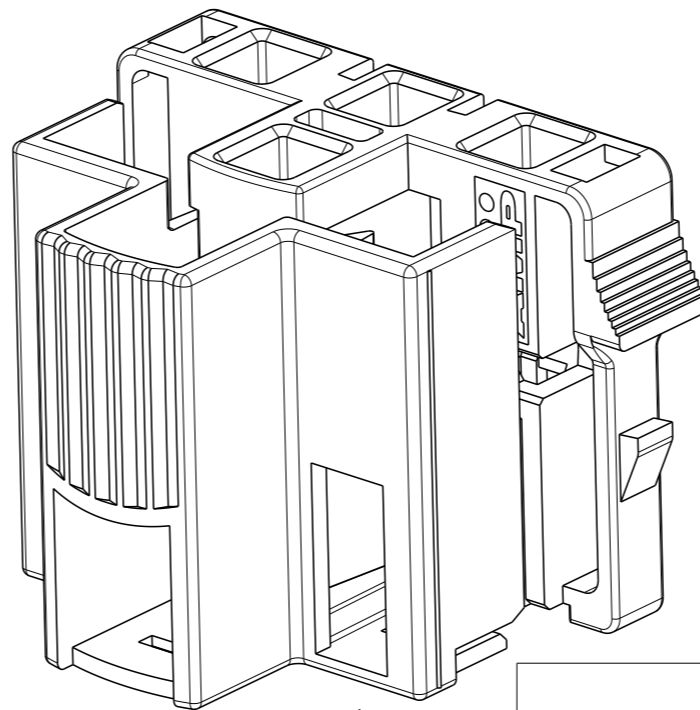

P/N 284101-1 AS SHOWN
 (P/N 284101-1 COME MOSTRATO)

P/N	ITEM	DESCRIPTION (DESCRIZIONE)	MATERIAL (MATERIALE)	COLOUR (COLORE)	QUANTITY (QUANTITA')
284101-2	2	SEC. LOCK (AGG. SEC.)	PA66	BLACK	1
	1	HOUSING (BLOCCHETTO)			1
284101-1	2	SEC. LOCK (AGG. SEC.)	PA66	NATURAL	1
	1	HOUSING (BLOCCHETTO)			1

THIS DRAWING IS A CONTROLLED DOCUMENT.
 QUESTO DISEGNO E' UN DOCUMENTO DI PROPRIETA' E RESPONSABILITA' DELL'AMP INCORPORATED. E' SOGGETTO A VARIAZIONI. PER OTTENERE L'ULTIMA REVISIONE DEL DISEGNO CONTATTARE L'UFFICIO TECNICO RESPONSABILE.

DIMENSIONS: DIMENSIONI: mm	TOLERANCES UNLESS OTHERWISE SPECIFIED: TOLLERANZE: SE NON DIVERSAMENTE SPECIFICATO
	0 PLC/DEC ±0.3 1 PLC/DEC ±0.3 2 PLC/DEC ±0.3 3 PLC/DEC ± 4 PLC/DEC ± ANGLES / ANGOLI ±2°
MATERIAL MATERIALE SEE TABLE (VEDERE TABELLA)	FINISH FINITURA SEE TABLE (VEDERE TABELLA)

DWN/DIS. D. BISETTI	16FEB1998
CHK/CONT. O. CANUTO	16FEB1998
APVD/APP. A. BRUNI	16FEB1998
PRODUCT SPEC SPEC DI PRODOTTO 108-20195	
APPLICATION SPEC SPEC DI APPLICAZIONE	
WEIGHT PESO	-
CUSTOMER DRAWING	DISEGNO PER CLIENTE SOLO PER RIFERIMENTO



4 VIE PER COMMUTATORE DI ACCENSIONE
 (4 POS. CONNECTOR FOR IGNITION KEY)

NAME NOME			
SIZE	CAGE CODE	DRAWING NO NUMERO	RESTRICTED TO
A300779	C-284101		-
SCALE SCALA	2:1	SHEET FOGLIO	1 OF 2 DI 2
REV	A2		

P		LTR REV	DESCRIPTION DESCRIZIONE	DATE DATA	DWN DIS.	APVD APP.
		-	SEE SHEET 1			

SECTION A-A
(SEZIONE A-A)

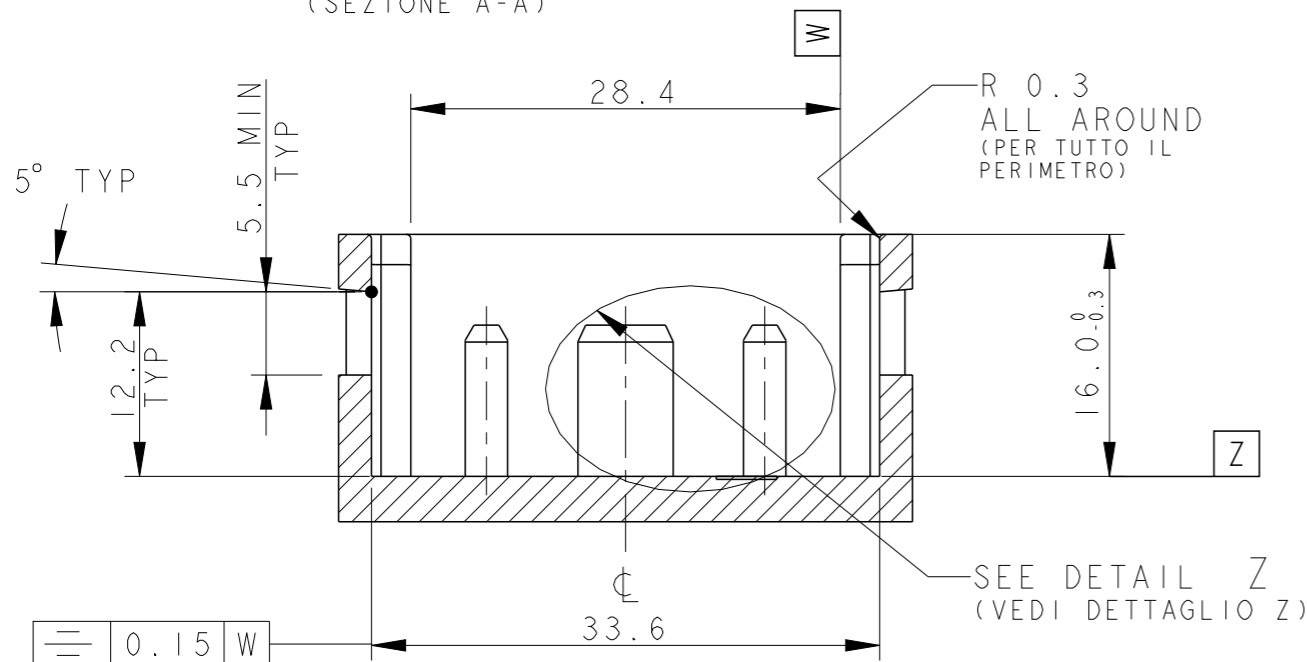

SECTION B-B
(SEZIONE B-B)

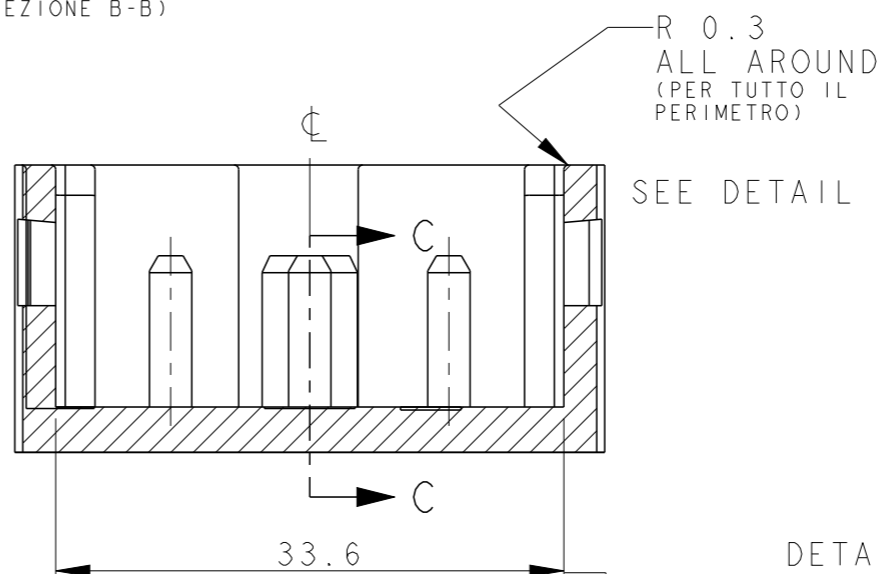

SECTION C-C
(SEZIONE C-C)

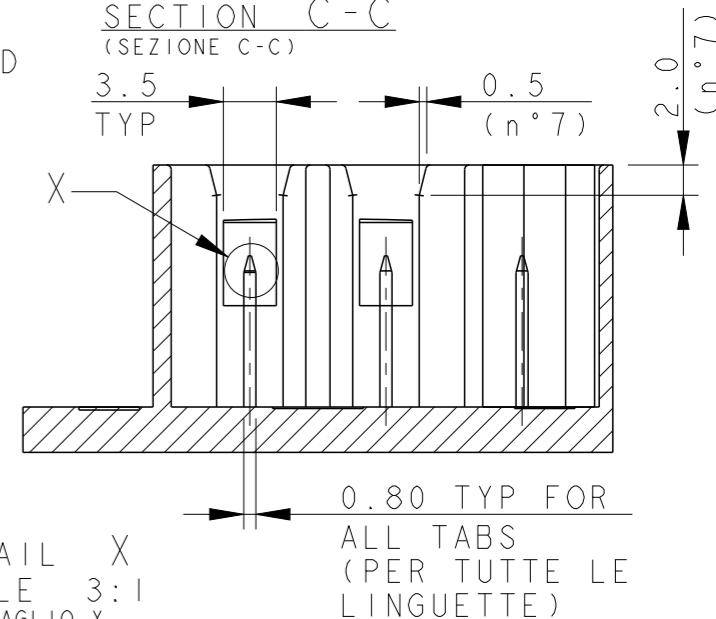

DETAIL Z
SCALE 3:1
(DETTAGLIO Z
SCALA 3:1)

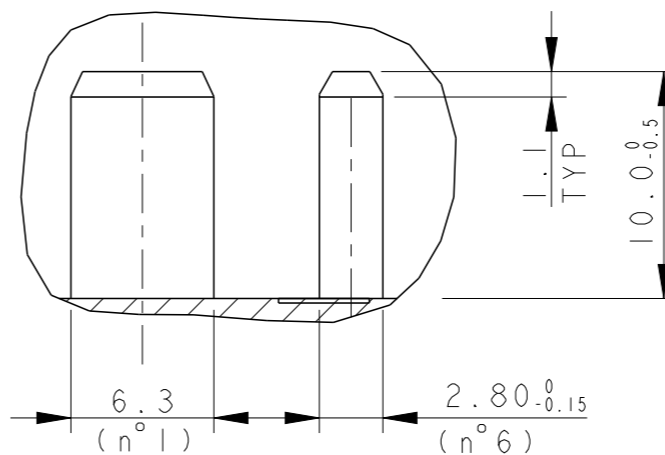

DETAIL X
SCALE 3:1
(DETTAGLIO X
SCALA 3:1)

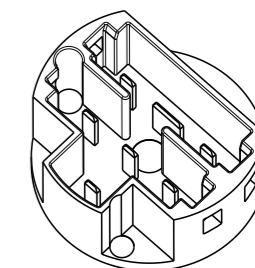
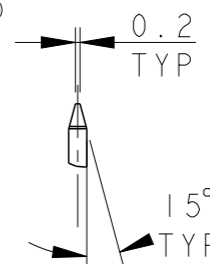



5 AREAS DEDICATED FOR RIVET APPLICATION (SPAZIO PER RIBATTINI DI FISSAGGIO)

6) POSSIBLE DRAFT ANGLES MUST BE INCLUDED IN THE TOLERANCES (LE EVENTUALI SPOGLIE DEVONO ESSERE COMPRESSE NELLE TOLLERANZE)

7) BODY MATERIAL : PA 6.6 G.F.FILLED (MATERIALE CORPO PA 6.6 CARICATO VETRO)
 TAB: TINNED BRASS THK TIN 2+5 μm (LINGUETTE IN OTTONE STAGNATO SPESSORE STAGNO 2+5 μm)

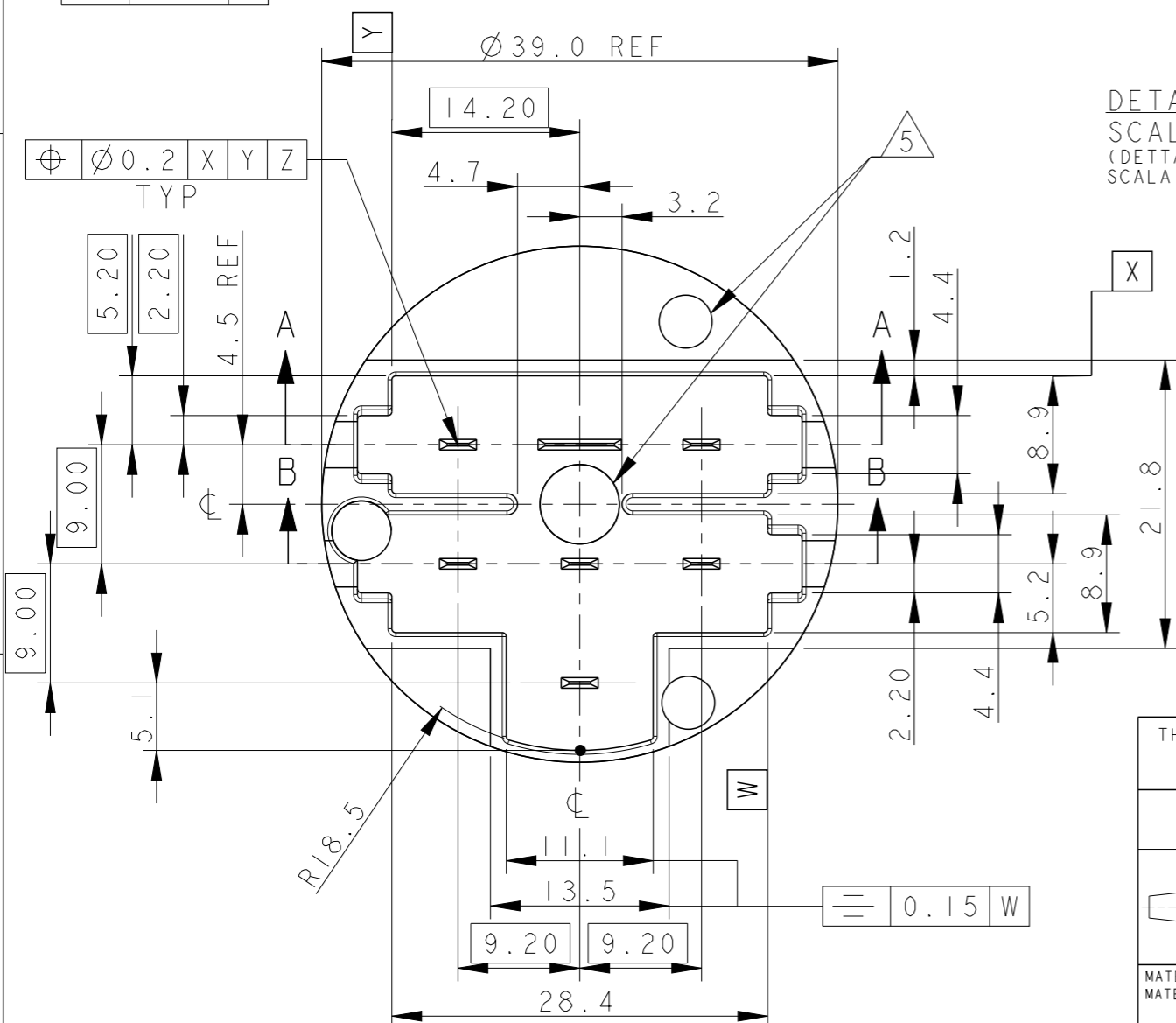
SEE SHEET 1 OF 1 FOR 4 POS. CONNECTOR & DRAWING 284098 FOR 3 POS. CONNECTOR (VEDERE FOGLIO 1 DI 1 PER CONNETTORE 4 VIE E DISEGNO 284098 PER CONNETTORE 3 VIE)



THIS DRAWING IS A CONTROLLED DOCUMENT. QUESTO DISEGNO È UN DOCUMENTO DI PROPRIETÀ E RESPONSABILITÀ DELL'AMP INCORPORATED. È SOGGETTO A VARIAZIONI. PER OTTENERE L'ULTIMA REVISIONE DEL DISEGNO CONTATTARE L'UFFICIO TECNICO RESPONSABILE.		DWN/DIS. 16FEB1998 D. BISETTI	 TE Connectivity	
DIMENSIONS: DIMENSIONI: mm		CHK/CONT. 16FEB1998 O. CANUTO		
TOLERANCES UNLESS OTHERWISE SPECIFIED: TOLLERANZE: SE NON DIVERSAMENTE SPECIFICATO		APVD/APP. 16FEB1998 A. BRUNI	NAME: DIMA DI MONTAGGIO PER CONNETTORI	
0 PLC/DEC ±0.3 1 PLC/DEC ±0.1 2 PLC/DEC ±0.05 3 PLC/DEC ± 4 PLC/DEC ± ANGLES/ANGOLI ±2°		PRODUCT SPEC SPEC DI PRODOTTO	3 E 4 POS. PER COMMUTATORE DI ACCENS. (COUNTERPART FOR 3 AND 4 POSITIONS CONNECTOR FOR IGNITION KEY)	
MATERIAL: SEE NOTE 7 (VEDERE NOTA 7)		APPLICATION SPEC SPEC DI APPLICAZIONE	SIZE A3	RESTRICTED TO
FINISH FINITURA: SEE NOTE 7 (VEDERE NOTA 7)		WEIGHT PESO	CAGE CODE 300779	DRAWING NO. NUMERO C-284101
CUSTOMER DRAWING		DESIGN FOR CLIENTE SOLO PER RIFERIMENTO	SCALE SCALA 2:1	SHEET FOGLIO 2 OF 2 DI 2 REV A2

单击下面可查看定价，库存，交付和生命周期等信息

[>>TE Connectivity\(泰科\)](#)