

REVISIONS				
REV	LYR	DESCRIPTION	DATE	APVD
F		REV & REDWN PER EC 0730-0059-95	3-21-95	KS
G		REVISED PER ECO-19-009931	05JUL2019	RS MZ

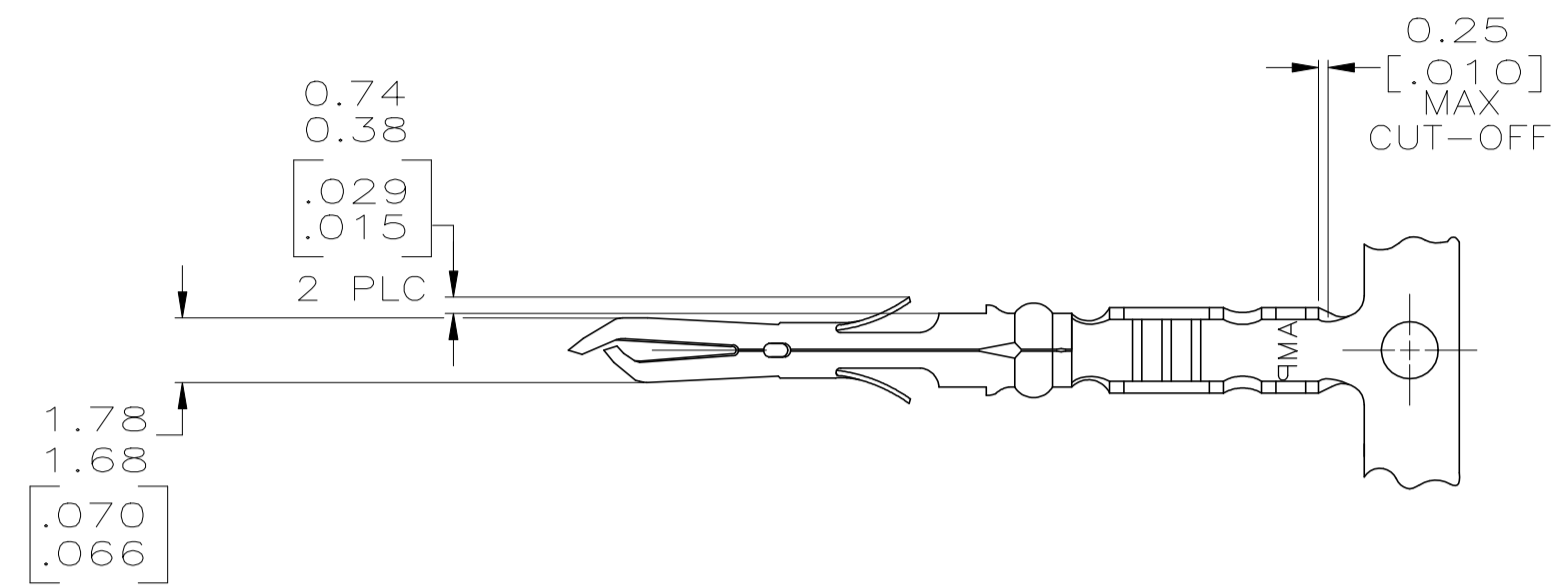

- 1 WIRE RANGE: 0.13-0.2mm² (26-24 AWG).
- 2 INSULATION RANGE: 0.64-1.27 [.025-.050] MAX. DIA.
- 3 DIMENSIONS IN BRACKETS ARE IN INCHES.
- 4 TIP PLATE WITH 0.00076-0.00091 [.000030-.000036] MIN GOLD IN THE LOCALIZED GOLD PLATE AREA OVER 0.00127 [.000050] MIN NICKEL UNDERPLATE.

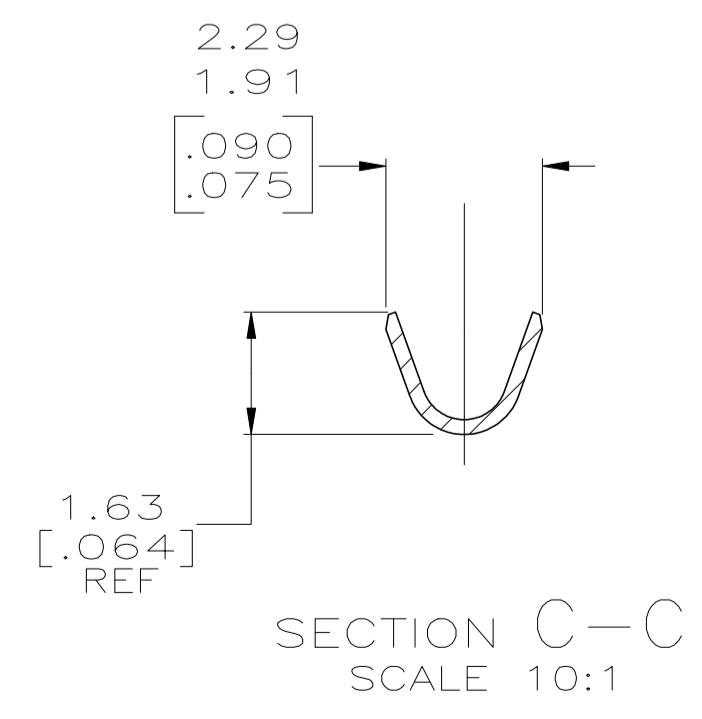
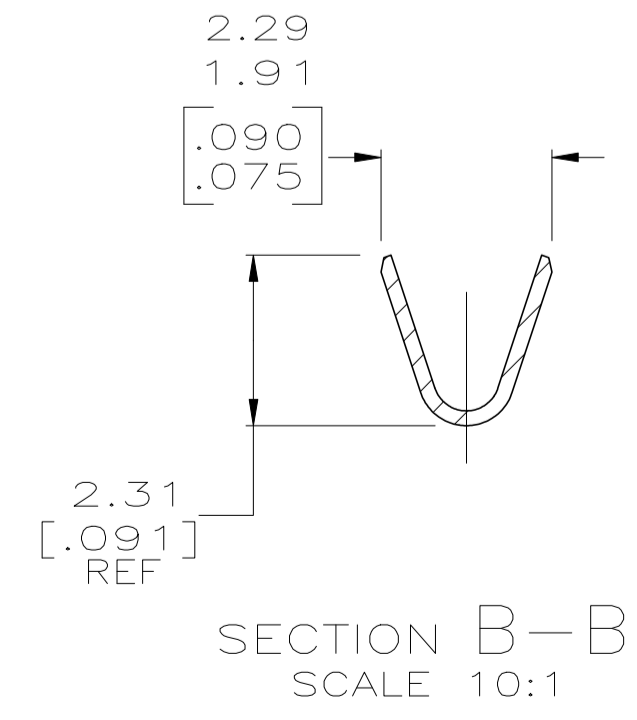
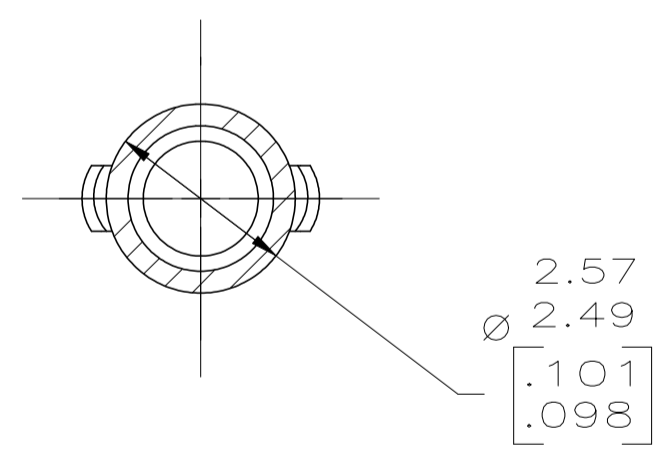
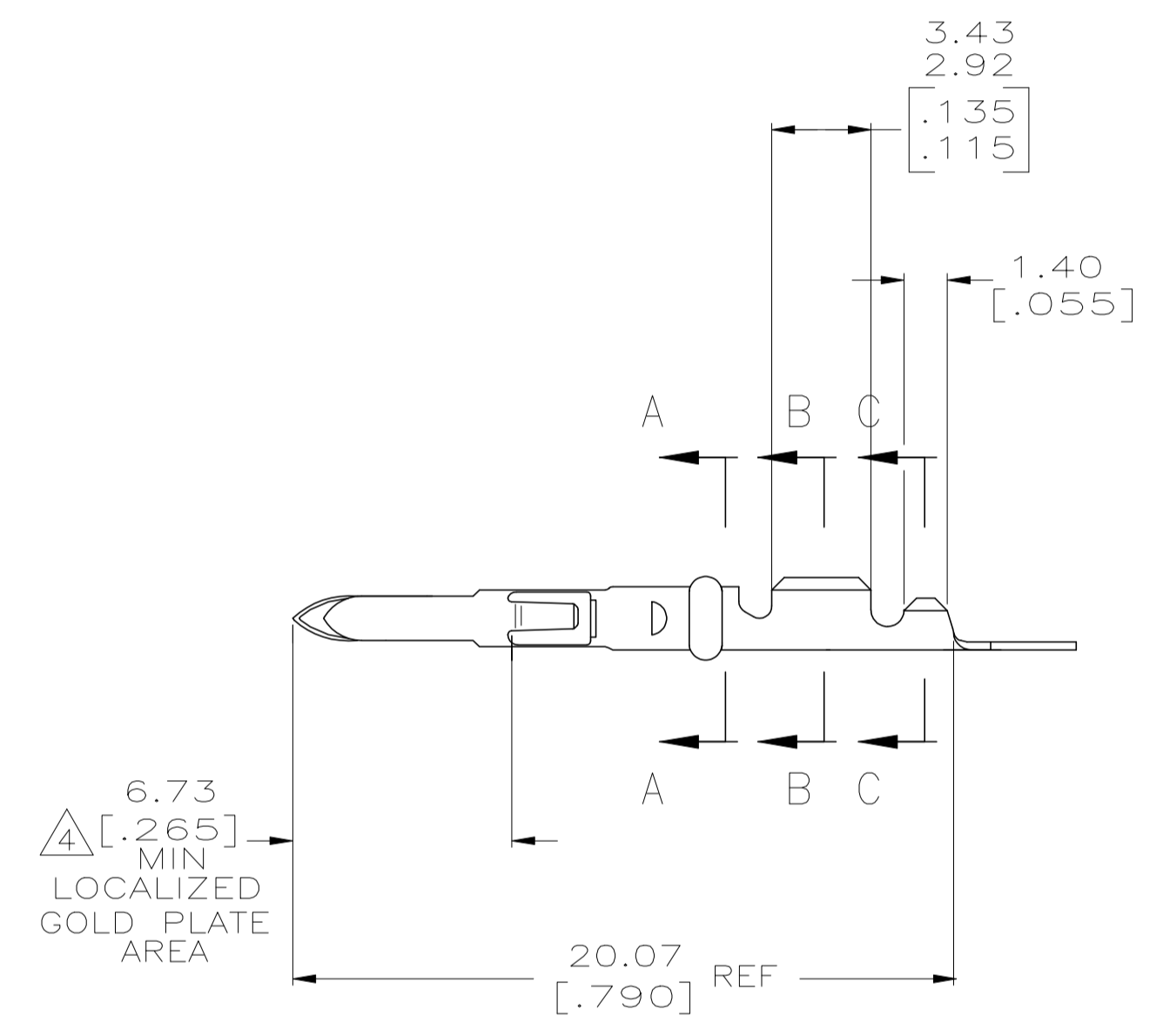
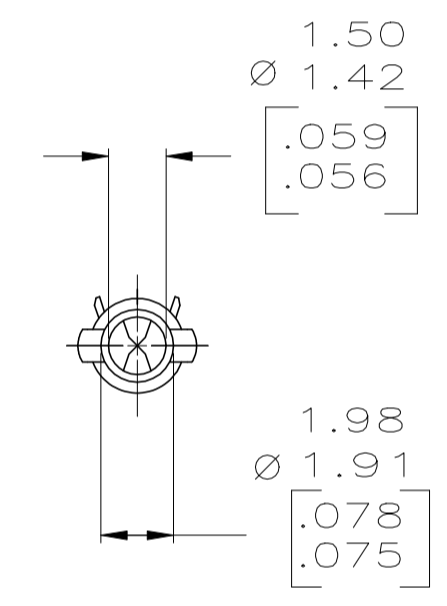

4 GOLD PLATE	0.20 [.008] PHOS BRZ	350968-2
PRE-TIN	0.20 [.008] PHOS BRZ	350968-1
FINISH	MATERIAL	PART NO

THIS DRAWING IS A CONTROLLED DOCUMENT.		DWN K. SALMON 3-21-95	STE TE Connectivity	
DIMENSIONS: mm [INCHES]		CHK R. SWING 3-21-95	MR PIN	
TOLERANCES UNLESS OTHERWISE SPECIFIED:		APVD W. LONG 3-21-95	RESTRICTED TO	
0 PLC ± -	1 PLC ± -	NAME	SIZE	CAGE CODE
2 PLC ± -	3 PLC ± 0.13 [.005]	APPLICATION SPEC	A1	00779
4 PLC ± -	ANGLES ± -	WEIGHT	SCALE	5:1
MATERIAL SEE TABLE	FINISH SEE TABLE	CUSTOMER DRAWING	SHEET 1 OF 1	REV G

METRIC

单击下面可查看定价，库存，交付和生命周期等信息

[>>TE Connectivity\(泰科\)](#)