

LOC		DIST		REVISIONS			
GP	00	REV	DATE	BY	CHK	APPV	
B		REVISED PER ECO-08-007327	22JUL08	BM	WM		
B1		REVISED PER ECO-10-000444	19JAN10	KK	HMR		

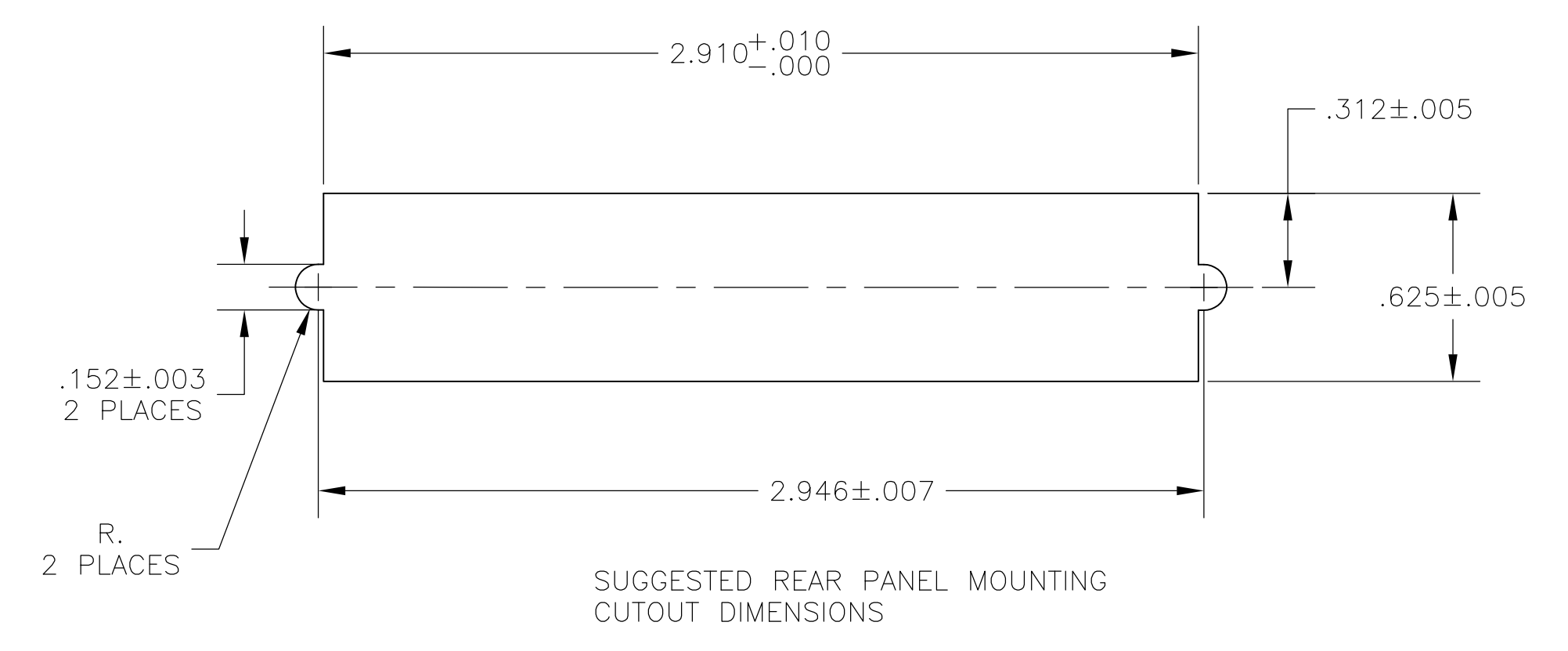
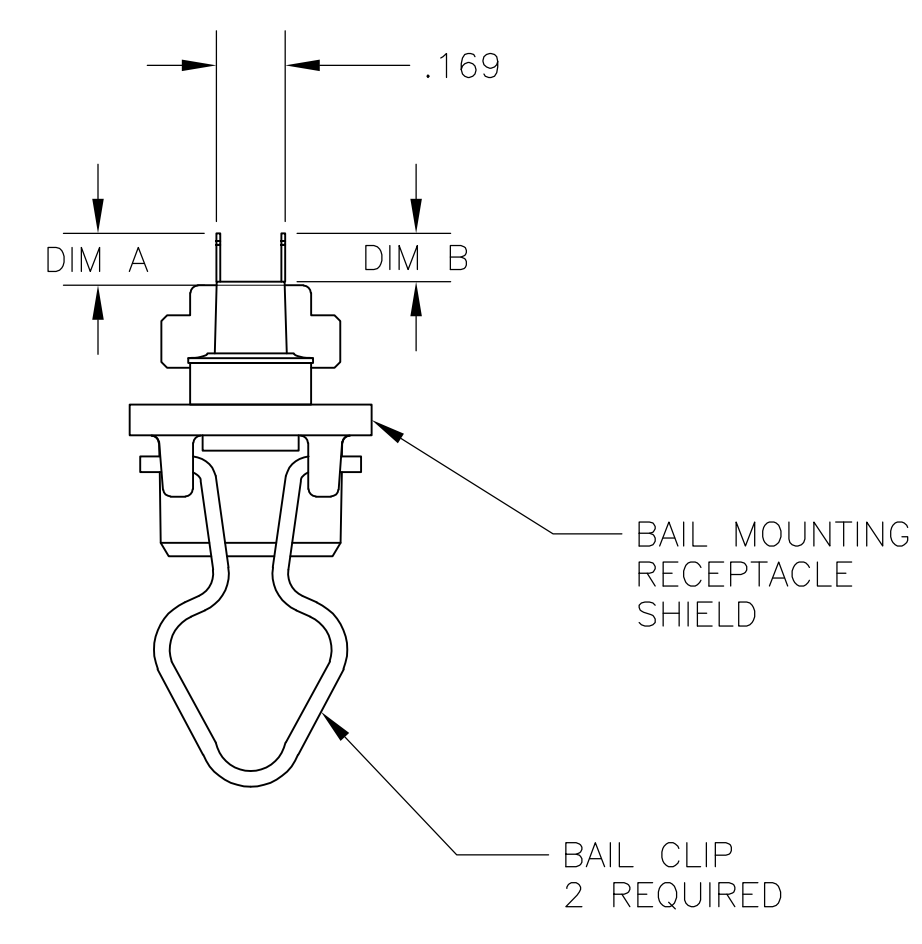
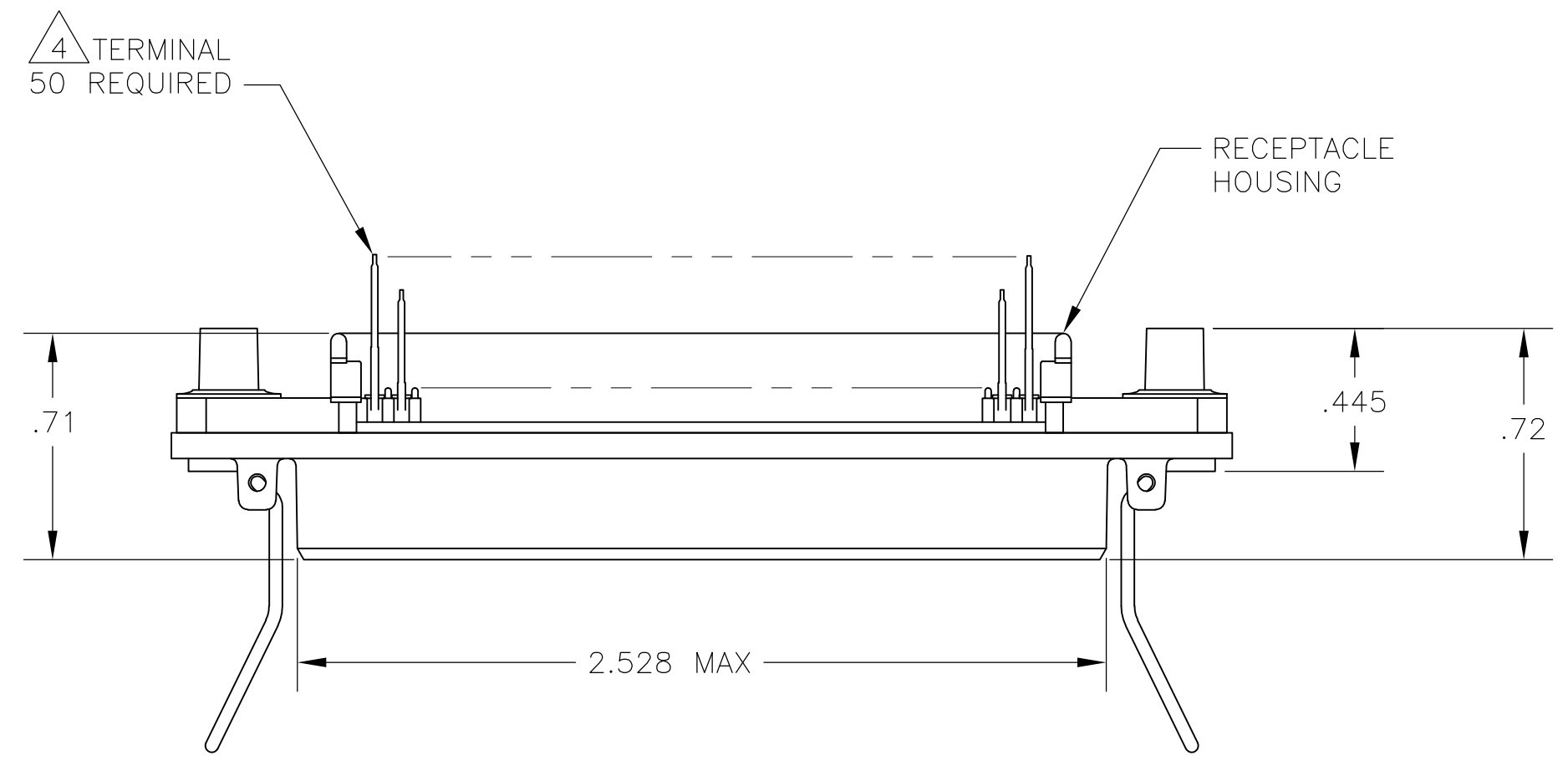
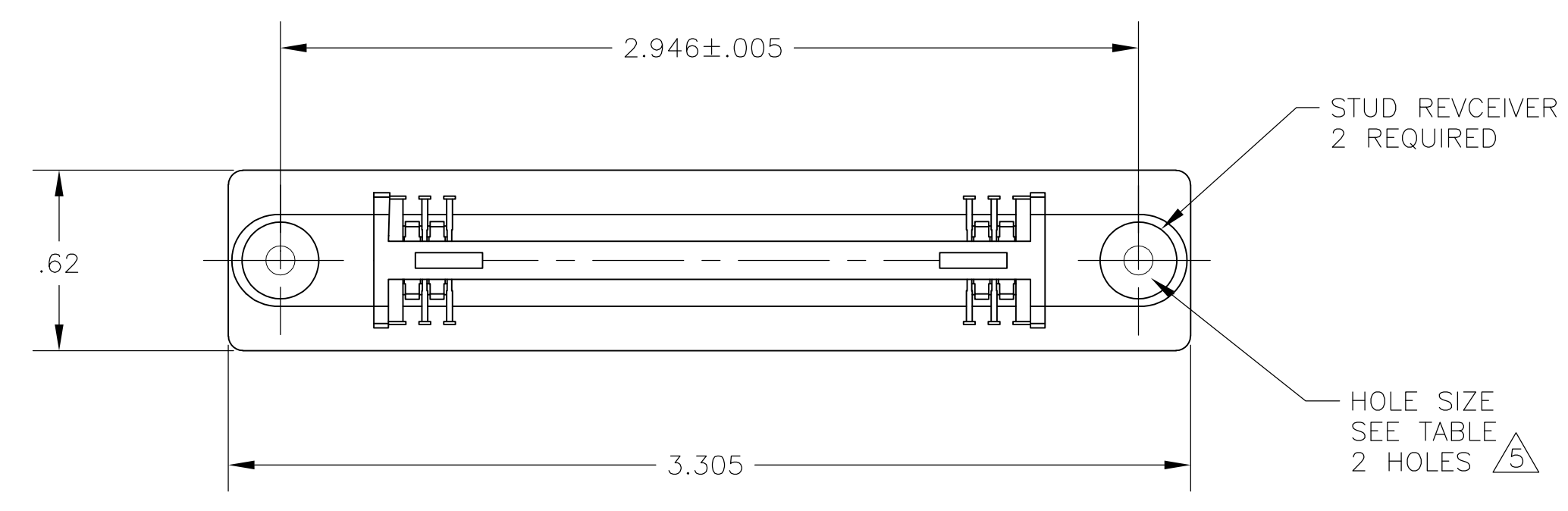

- THE CONTACT SURFACES OF THE TERMINALS ARE COATED WITH LUBRICANT.
- ALL DIMENSIONS SHOWN ARE FOR REFERENCE ONLY UNLESS OTHERWISE SPECIFIED.
- MATERIAL:
 HOUSING - THERMOPLASTIC, BLACK
 TERMINAL - PHOS BRONZE PLATED WITH EITHER .000030 MINIMUM GOLD PLATE OR GOLD FLASH OVER PALLADIUM NICKEL PLATE, .000030 MINIMUM TOTAL ON MATING SURFACE. .000120 MINIMUM TIN PLATE ON TAILS OVER .000050 MINIMUM NICKEL UNDERPLATE OVER ENTIRE TERMINAL.
 STUD RECEIVER - STAINLESS STEEL
 BAIL CLIP - STAINLESS STEEL
 SHIELD - NICKEL PLATED DIE CASTING.
- CENTER-TO-CENTER SPACING OF TERMINALS IS .085.
- HOLES TO BE TAPPED AFTER PLATING.
- OBsolete PARTS: OBsolete CIS STREAMLINING PER D.RENAUD/D.SINISI

OBSOLETE	.232 + PANEL THICKNESS	.197 + PCB THICKNESS	4-40 UNC-2B	.185	.200	5554216-4
	PANEL SIDE	PCB SIDE	HOLE SIZE	.120	.135	5554216-3
RECOMMENDED HARDWARE FOR SCSI (PAN HEAD SCREW LENGTH)			PART NO			
THIS DRAWING IS A CONTROLLED DOCUMENT.			Tyco Electronics Corporation Harrisburg, PA 17105-3608			
DIMENSIONS: INCHES		TOLERANCES UNLESS OTHERWISE SPECIFIED:		NAME: RCPT ASSY, 50 POSN, VERT MTG, SHLD, BAIL LK, CHAMP		
0 PLC ± -		1 PLC ± -		PRODUCT SPEC		
2 PLC ± -		3 PLC ± -		APPLICATION SPEC		
4 PLC ± -		ANGLES ± -		SIZE: A1		
MATERIAL		FINISH		WEIGHT: -		
CUSTOMER DRAWING			SCALE: 2:1		SHEET 1 OF 1 REV B1	

单击下面可查看定价，库存，交付和生命周期等信息

[>>TE Connectivity\(泰科\)](#)