

DRAWING MADE IN AMERICAN PROJECTION

© COPYRIGHT 1973 BY AMP INCORPORATED, HARRISBURG, PA. ALL INTERNATIONAL RIGHTS RESERVED.

Unpublished copy not to be reproduced without written permission of AMP Incorporated

THIS PRODUCT DESIGNED AND BUILT BY AMP INCORPORATED. NO LICENSE TO USE THAT DESIGN IN MANUFACTURE, OR TO USE ANY ISSUED OR PENDING PATENTS WHICH ARE INVOLVED, IS IMPLIED.

REVISIONS				
ZONE	LTR	DESCRIPTION	DATE	APPROVED
	A	REV. & REDRAWN	6-4-73	Ken X
✓	B	OBSOLETE -2 ECN 53630	1-29-87	JM
	C	REV PER ECN S-3960	4-12-87	R8
	D	REACTIVATE -2 DF-7279 CT	2-93	DE 2/11/93
	E	ECO-10-007742 PY	4-10	DE

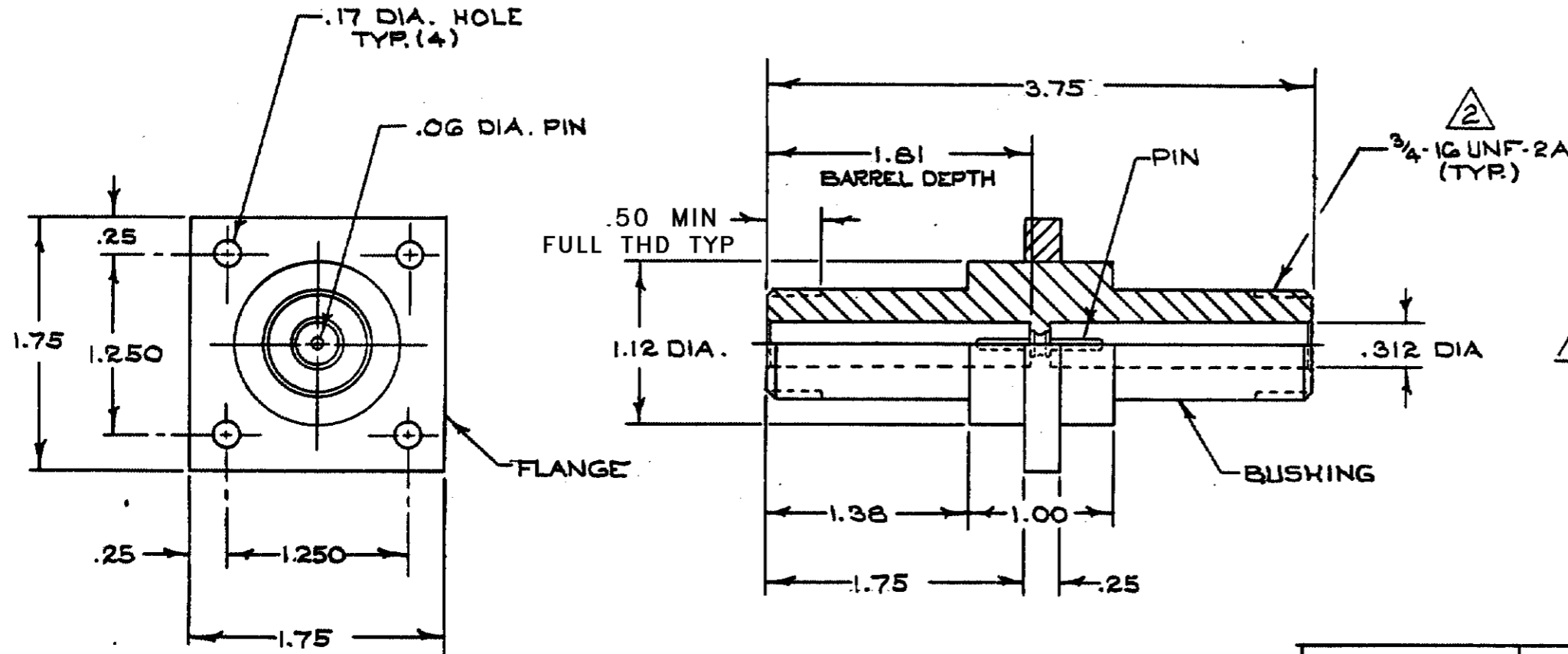

1 RECEPTACLE TO MATE WITH AMP LGH -3 LEAD ASSEMBLY, AVAILABLE SEPARATELY.
 2 PER FEDERAL STANDARD H-2B 3 WIRE METHOD. DIMENSION OVER WIRES TO BE: .7474 - .7654.

850909-2	AS SHOWN WITH GOLD PLATED PIN
850909-1	AS SHOWN WITH TIN PLATED PIN

QTY REQD	QTY REQD	ITEM NO	DWG SIZE	PART OR IDENTIFYING NO	NOMENCLATURE OR DESCRIPTION	SYMBOL
-2	-1					

UNLESS OTHERWISE SPECIFIED: DECIMALS } .00 = ±.02 .000 = ±.005 ANGLES = ± HOLES } UNDER .251 = .251 TO .500 = OVER .500 = DIMENSIONS ARE IN INCHES				CONTRACT NO		AMP INCORPORATED Elizabethtown, Pa.	
MATERIAL MOLDED GLASS EPOXY				DR L. GEIB 6-10-69			
FINISH BLACK				APPD		SIZE B	
NEXT ASSY				DSGN APPD J.W. GAW 6-12-69		CODE IDENT NO 89110	
FINAL ASSY				OTHER APPD		NUMBER 850909	
NEXT ASSY						REV E	
USED ON						SCALE	
QTY REQD				APPLICATION		WT	
						SHEET OF	

DO NOT SCALE PRINT

CUSTOMER DRAWING

单击下面可查看定价，库存，交付和生命周期等信息

[>>TE Connectivity\(泰科\)](#)