

If this document is printed it becomes uncontrolled.
Check for the latest revision.

REVISION		DATE
REV	DESCRIPTION	
A	REVISED PER DCR NO. T-31578	6/11/03

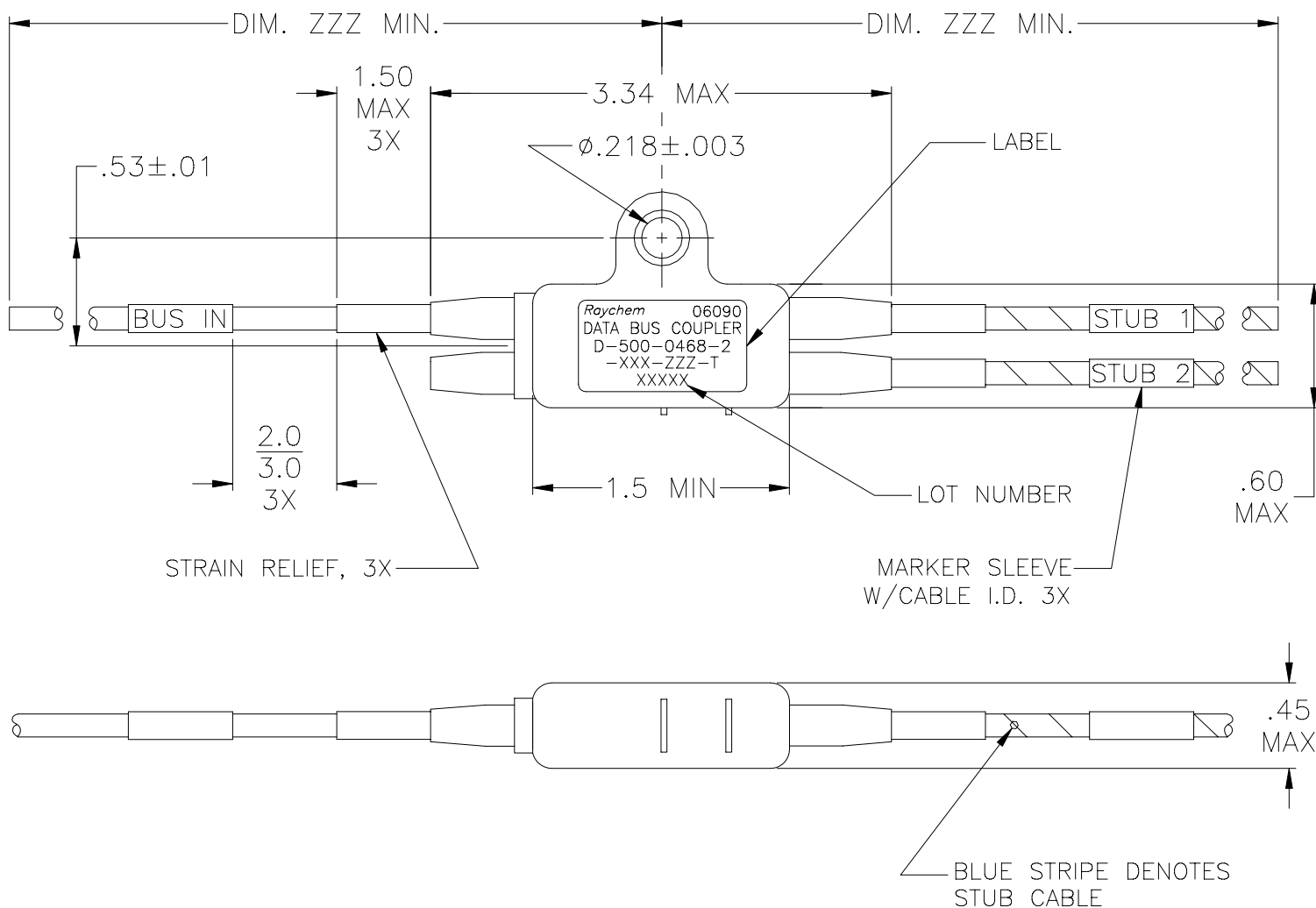

PART NO. D-500-0468-2-XXX-ZZZ-T

2=DOUBLE STUB TUBING, STRAIN RELIEF
 LENGTH OF CABLE IN INCHES
 CABLE
 612=10612 (SINGLE OPTIMIZED BRAID)
 613=10613 (DOUBLE OPTIMIZED BRAID)
 614=10614 (EMP HARDENED)

SPECIFICATION CONTROL DRAWING

UNLESS OTHERWISE SPECIFIED DIMENSIONS ARE INCHES. METRIC DIMENSIONS ARE IN BRACKETS.

DRAWN T RATZLAFF DATE 01JAN16

tyco Tyco Electronics
Electronics 300 CONSTITUTION DRIVE
 MENLO PARK, CALIFORNIA 94025 USA *Raychem*

DECIMAL TOLERANCES
 .XXX ± --- [--- mm]
 .XX ± --- [--- mm]
 .X ± --- [--- mm]

TITLE DATABUS COUPLER, DOUBLE STUB
 IN-LINE W/CABLE STRAIN RELIEF
 REVERSE W/INTERNAL TERMINATOR,
 & MOUNTING LUG

ANGLE TOLERANCE
 .X ± ---
 WEIGHT FINISH
 SEE NOTES

THIRD ANGLE PROJECTION
 SIZE A CODE IDENT. NO. 06090 DWG. NO. D-500-0468-2-XXX-ZZZ-T

1. MATERIAL AND FINISHES:

1.1 INTERNAL COMPONENTS:

- 1.1.1 -TRANSFORMER TO MIL-PRF-21038 AND MIL-STD-1553B
 1.1.2 -RESISTORS, ISOLATION PER MIL-PRF-39007/9, 57.6 OHMS (R1)
 1.1.3 -RESISTORS, TERMINATION PER MIL-PRF-39007/9, 76.8 OHMS (R2)
 1.2 SHIELDED CASE: ALUMINUM PER ASTM-B618

1.3 SEALED STRAIN RELIEF COVER: MODIFIED CROSS-LINKED ELASTOMER, BLACK, TO RAYCHEM SPECIFICATION RK-6713.

1.4 CABLE TYPE PER RAYCHEM SPECIFICATION 1200 (SEE PART NO. ON SHEET 1).

1.5 STRAIN RELIEF TUBING: RAYCHEM TAT-125

2. APPLICATION:

2.1 THIS COUPLER IS DESIGNED TO BE INSTALLED AS A DIGITAL MULTIPLEX ASSEMBLY MEETING THE REQUIREMENTS OF MIL-STD-1553B.

2.2 FOR CABLE SPLICING USE FLEXIBLE SPLICE KIT D-150-0708-5 (NOT SUPPLIED).

2.3 CABLE BEND RADIUS PER SAE-AS50881 STATIC BEND: 5 x CABLE O.D. MIN.
 DYNAMIC BEND: 10 x CABLE O.D. MIN.

3. TEMPERATURE:

3.1 OPERATING TEMPERATURE: -65°C TO +150°C

4. PERFORMANCE SPECIFICATIONS:

4.1 TRANSFORMER MEETS THE PERFORMANCE REQUIREMENTS OF MIL-STD-1553B.

4.2 COUPLER MEETS THE PERFORMANCE REQUIREMENTS OF RAYCHEM SPECIFICATION D-6020.

5. WEIGHT:

5.1 MAXIMUM WEIGHT WITHOUT CABLE: 23 GRAMS MAX.

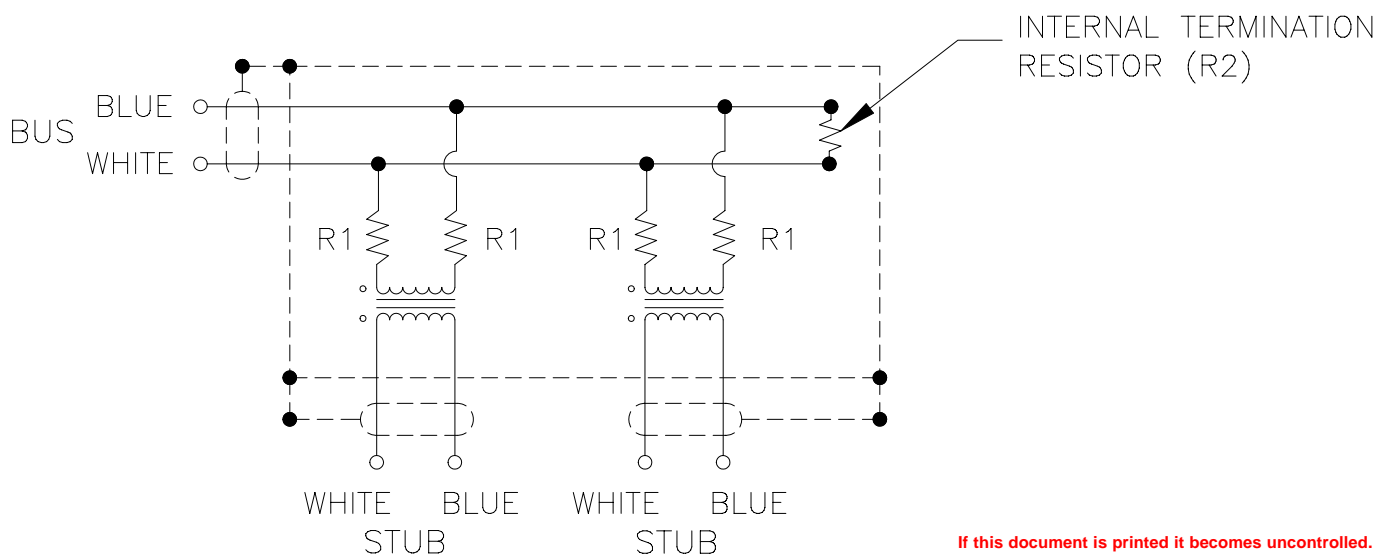
DOUBLE STUB COUPLER SCHEMATIC

If this document is printed it becomes uncontrolled.
 Check for the latest revision.

SPECIFICATION CONTROL DRAWING

DRAWN T RATZLAFF	DATE 01JAN16	SIZE A	CODE IDENT. NO. 06090	DWG. NO. D-500-0468-2-XXX-ZZZ-T	REV A
CAD FILE T31578B	tyco Electro	Downloaded From Oneyac.com		SHEET 2 OF 2	

单击下面可查看定价，库存，交付和生命周期等信息

[>>TE Connectivity\(泰科\)](#)