

THIS DRAWING IS UNPUBLISHED. RELEASED FOR PUBLICATION APRIL, 2004.
 © COPYRIGHT 2004 By - ALL RIGHTS RESERVED.

LOC	DIST	REVISIONS			
P	LTR	DESCRIPTION	DATE	DWN	APVD
E	B	A1	REVISED PER ECO-11-005033	01APR11	RK HMR

- NOTES:
- 1 SINGLE PACK IN ACCORDANCE WITH SPEC 107-3275
 - 2 100 TRAY PACK IN ACCORDANCE WITH SPEC 107-3275
 - 3 0.08µm Au PLATING OVER 1.27µm Ni PLATING
 - 4 0.08µm Au PLATING OVER 1.27µm Ni PLATING OVER 0.76µm Cu PLATING
 - 5 0.76µm Au PLATING OVER 1.27µm Ni PLATING OVER 0.76µm Cu PLATING
 - 6 PASSIVATED
 - 7 WHITE BRONZE PLATING
 - 8 PLATING AS PER BODY, EXCEPT FOR PASSIVATED WHICH IS NICKEL PLATED
- 9 HAND TOOL 9-1478240-0
 10 DIE SET 9-1478242-0
 11 FOR TECHNICAL DATA REFER TO YOUR LOCAL TE CONNECTIVITY SALES OFFICE
 12 ALL DIMENSIONS ARE NOMINAL FOR REFERENCE ONLY UNLESS OTHERWISE STATED

RECOMMENDED
CRIMP SLEEVE
A/F HEX

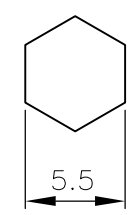

RECOMMENDED
CABLE STRIPPING DIM'S

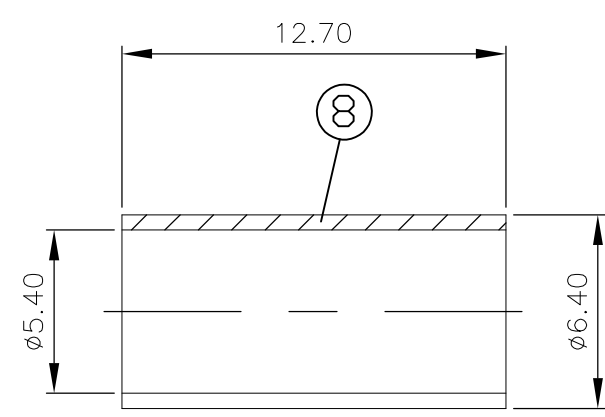
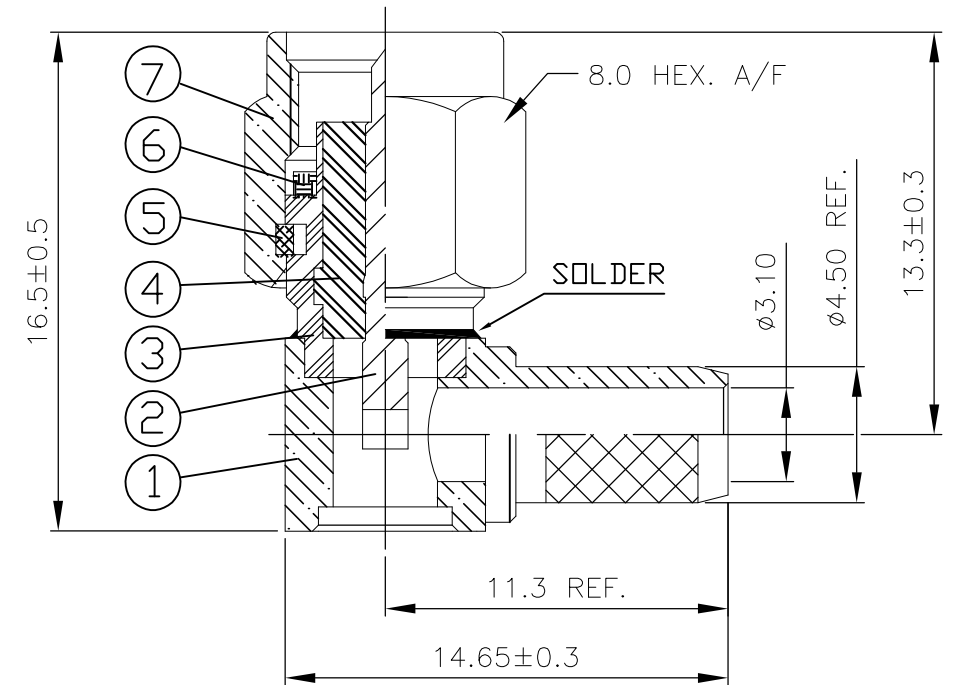
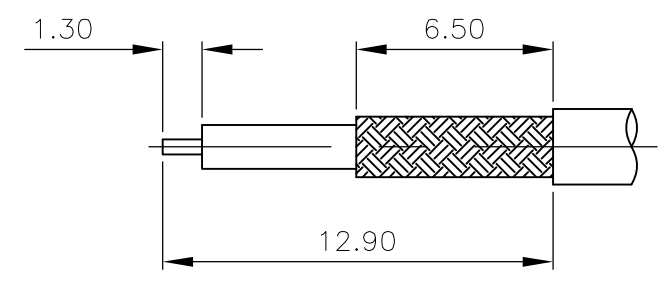

QTY	LOC	DIST	P	LTR	DESCRIPTION	DATE	DWN	APVD	ITEM	
1	1	-	-	-	BRASS				9	
-	-	1	1	-	BRASS				9	
-	-	-	-	1	1	STAINLESS STEEL			9	
-	-	-	-	-	1	STAINLESS STEEL			9	
1	1	1	1	1	1	1	1	BRASS	8	
1	1	-	-	-	-	-	-	BRASS	7	
-	-	1	1	-	-	-	-	BRASS	7	
-	-	-	-	1	1	-	-	STAINLESS STEEL	7	
-	-	-	-	-	-	1	1	STAINLESS STEEL	7	
1	1	1	1	1	1	1	1	SILICON	6	
1	1	1	1	1	1	1	1	STAINLESS STEEL	5	
1	1	1	1	1	1	1	1	PTFE	4	
1	1	-	-	-	-	-	-	BRASS	3	
-	-	1	1	-	-	-	-	BRASS	3	
-	-	-	-	1	1	-	-	STAINLESS STEEL	3	
-	-	-	-	-	-	1	1	STAINLESS STEEL	3	
1	1	1	1	1	1	1	1	BRASS	2	
1	1	-	-	-	-	-	-	BRASS	1	
-	-	1	1	-	-	-	-	BRASS	1	
-	-	-	-	1	1	-	-	STAINLESS STEEL	1	
-	-	-	-	-	-	1	1	STAINLESS STEEL	1	
4--1	4--0	3--1	3--0	2--1	2--0	1--1	1--0	MATERIAL	DESCRIPTION	ITEM
2	1	2	1	2	1	2	1			

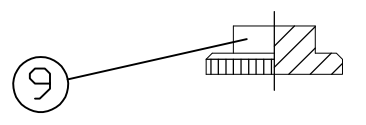

THIS DRAWING IS A CONTROLLED DOCUMENT.

DWN R.SMITH 10FEB04
 CHK S.PARLOW 10FEB04
 APVD F.WHEELER-KING 10FEB04

STE TE Connectivity

SMA RIGHT ANGLE CRIMP ATTACHMENT
 CAPTIVE CONTACT
 RG58C/U, 141A/U, URM43, URM76, KX15

108-3460
 APPLICATION SPEC
 411-3276
 WEIGHT -

SIZE A3 CAGE CODE 00779 DRAWING NO C-1478923 RESTRICTED TO -

CUSTOMER DRAWING SCALE 1:1 SHEET 1 OF 1 REV A1

单击下面可查看定价，库存，交付和生命周期等信息

[>>TE Connectivity\(泰科\)](#)