

THIS DRAWING IS UNPUBLISHED. RELEASED FOR PUBLICATION
 © COPYRIGHT - By - ALL RIGHTS RESERVED.

LOC	DIST	REVISIONS			
P	LTR	DESCRIPTION	DATE	DWN	APVD
AF	50	B	WIRE SIZE EXTENDED TO 16.5AWG	11NOV2019	JA PKS

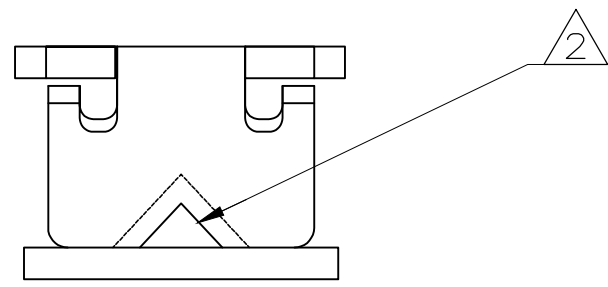

- ① SLOT ACCEPTS 0.91–1.20mm [#19–#16.5] AWG COPPER MAGNET WIRE.
 SLOT ACCEPTS 0.95–1.20mm [#18.5–#16.5] AWG ALUMINUM MAGNET WIRE.
 ALUMINUM WIRE RANGE APPLIES FOR POST-TIN PLATED VERSIONS ONLY. A SINGLE WIRE ONLY.
- ② POKE-IN ACCEPTS A 0.50–0.90mm² [#20–#18] AWG SOLID OR FUSED STRANDED LEAD WIRE.
- ③ ORANGE COLOR STRIPE TO BE APPLIED TO THIS SURFACE DURING LOOSE PIECE OPERATIONS TO PROVIDE COLOR CODING OF MAGNET WIRE RANGE.

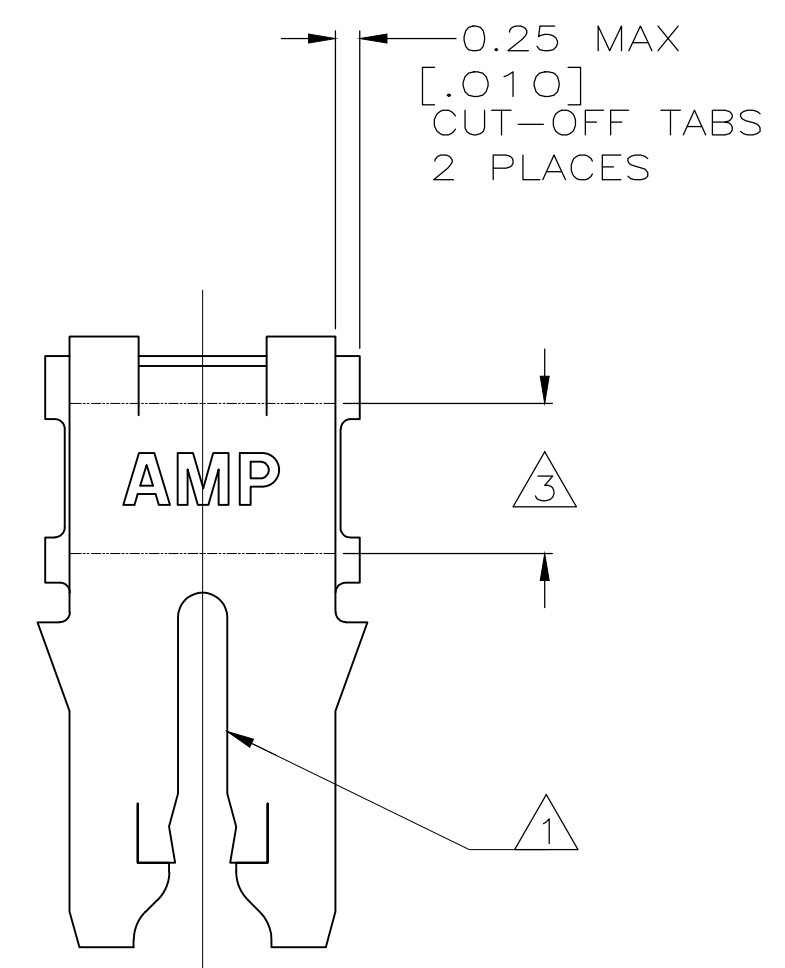
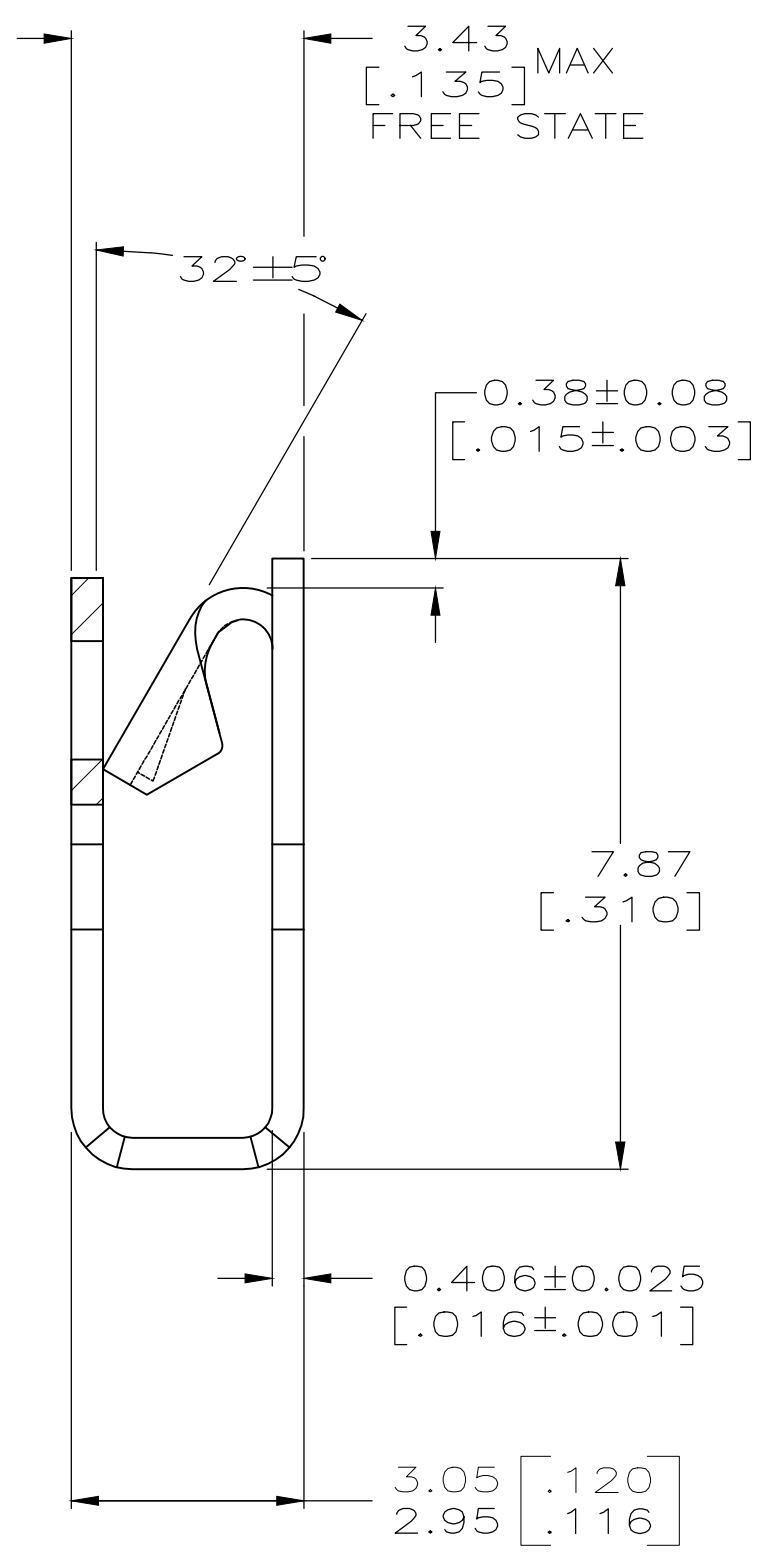
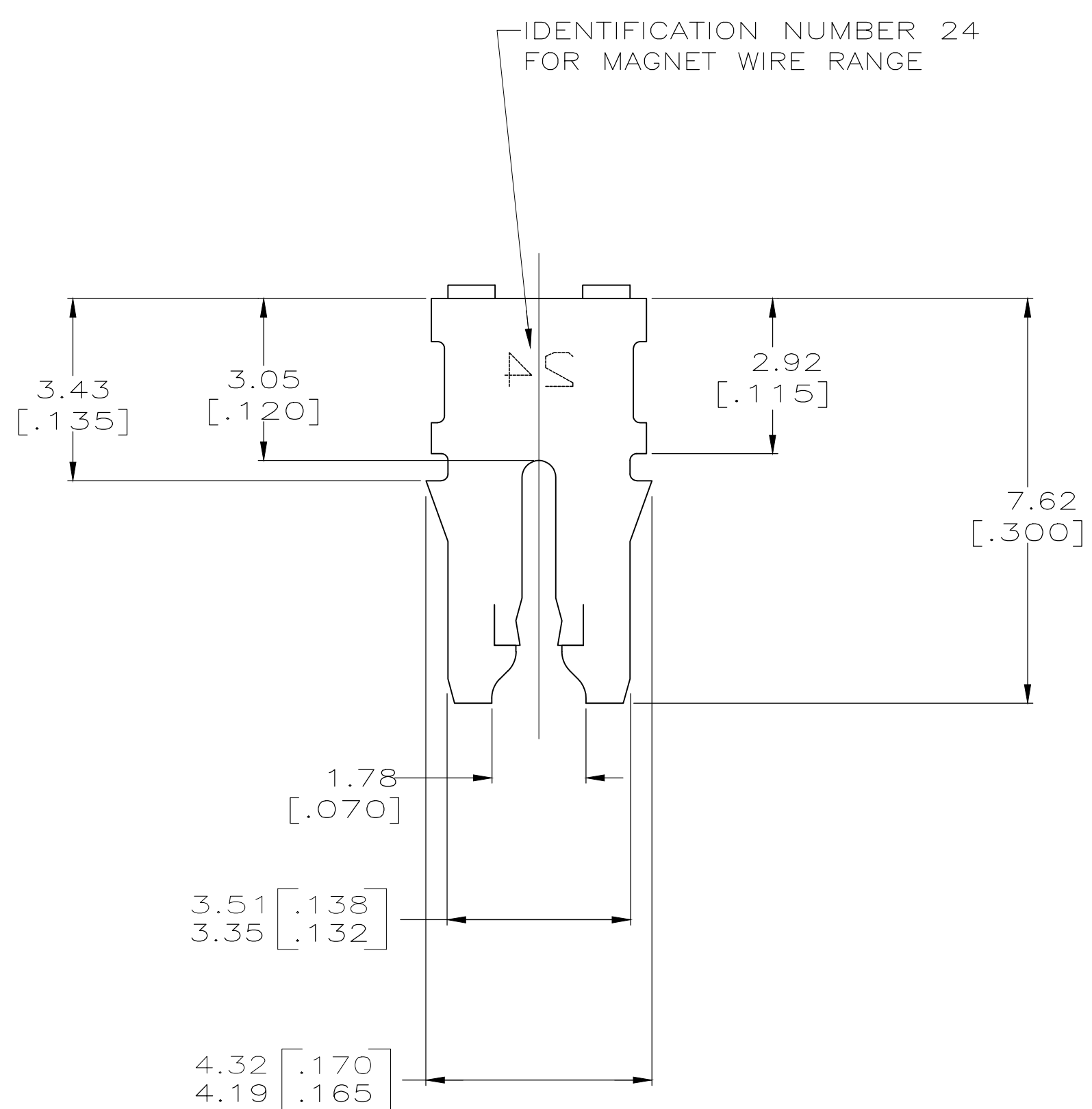

62912-1
 PART NUMBER

THIS DRAWING IS A CONTROLLED DOCUMENT.		DWN MICHAEL S. FEHER 17JUL2000	STE TE Connectivity	
DIMENSIONS: INCHES		CHK KURT A. RANDOLPH 17JUL2000		
TOLERANCES UNLESS OTHERWISE SPECIFIED:		APVD KURT A. RANDOLPH 17JUL2000	NAME KURT A. RANDOLPH	
0 PLC ± - 1 PLC ± - 2 PLC ± 0.25[.010] 3 PLC ± - 4 PLC ± - ANGLES ± -		PRODUCT SPEC 108-2012	TERMINAL, POKE-IN, LOOSE PIECE, 300 SERIES MAG-MATE	
MATERIAL BRASS		FINISH TIN PLATED	APPLICATION SPEC 114-2046	RESTRICTED TO -
		WEIGHT -	SIZE A2	CAGE CODE 00779
		CUSTOMER DRAWING	DRAWING NO C=62912	SCALE 10:1
			SHEET 1 of 1	REV B

单击下面可查看定价，库存，交付和生命周期等信息

[>>TE Connectivity\(泰科\)](#)