

THIS DRAWING IS UNPUBLISHED.

RELEASED FOR PUBLICATION

ALL RIGHTS RESERVED.

© COPYRIGHT - By -

VERWENDET FÜR 

REVISIONS

| P | LTR | DESCRIPTION | DATE | DWN | APVD |
|---|-----|--|-----------|-----|------|
| | A4 | GOLD PLATING THICKNESS CORRECTED AS 0.76µm | 02AUG2016 | RP | PS |

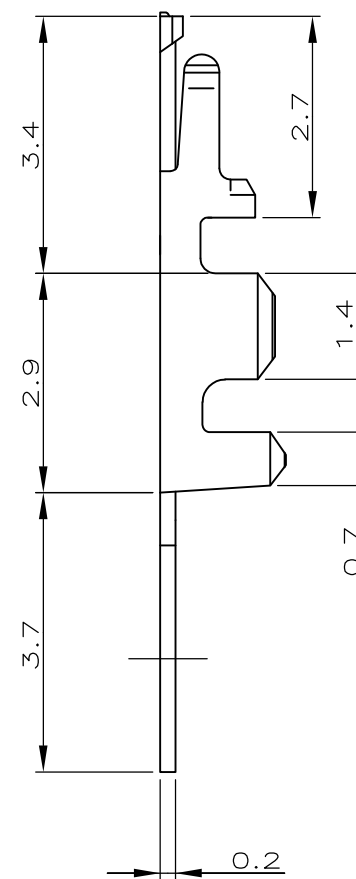
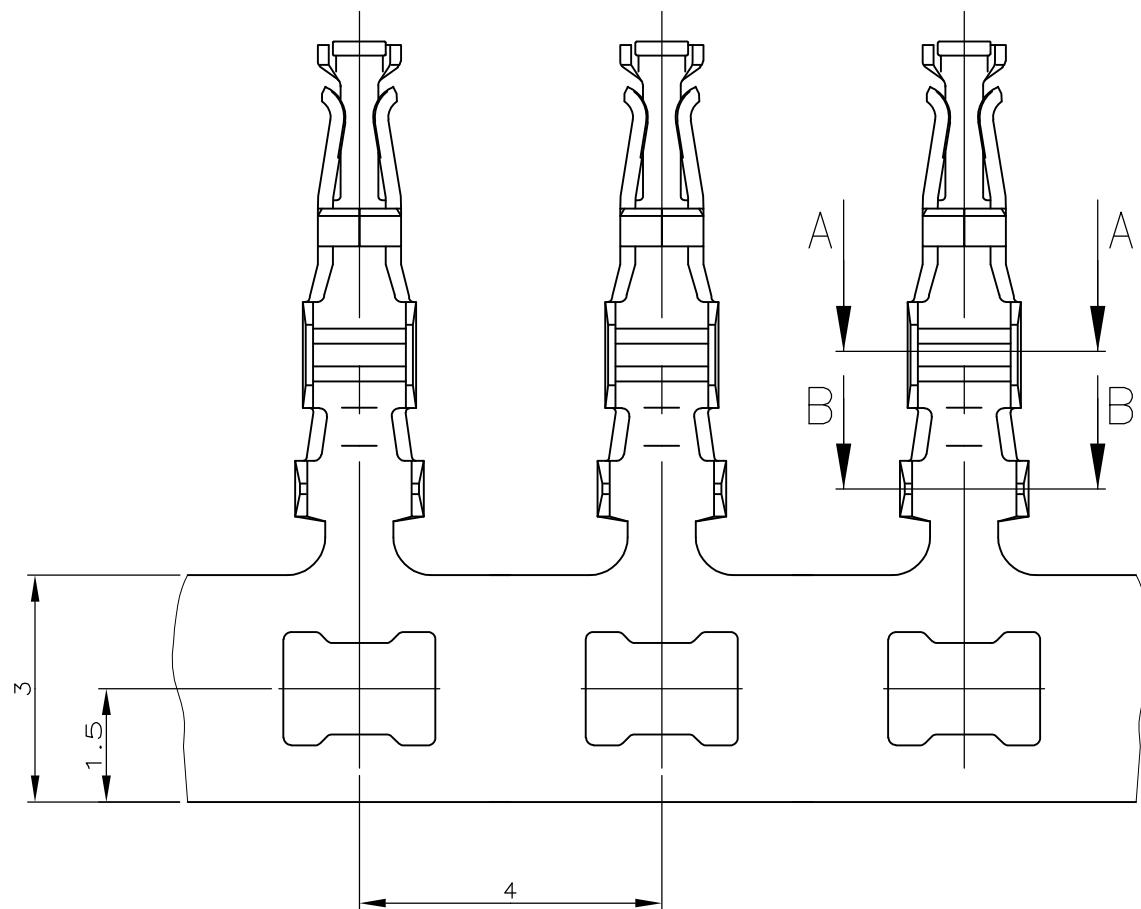

SECTION "A"-"A"
AWG 28-24: (0.08-0.22)mm²

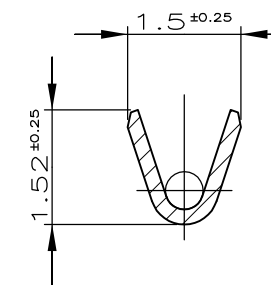

SECTION "B"-"B"
MAX ISO Ø 1.0

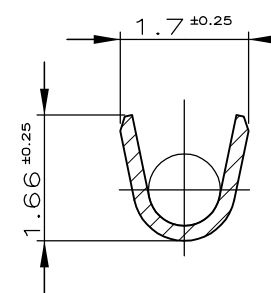

BEMERKUNGEN:

 STECKBEREICH: 0.76µm Au ÜBER 1.27µm Ni
CRIMPBEREICH: VERZINNT

2. AWG 28-24
ISO-Ø max 1.0

 PASSEND ZU BUCHSENGEHÄUSE: PN 964 976

4. VERARBEITUNGSSPEZIFIKATION 114-18172
PRODUKTSPEZIFIKATION 108-18544

ZEICHNUNG GÜLTIG AB KW 19/97...

THIS DRAWING IS A CONTROLLED DOCUMENT.

DWN 17-APR-96
F.REICHARDT

CHK -
M.SCHAARSCHMIDT

APVD -

PRODUCT SPEC -

APPLICATION SPEC -

WEIGHT -

CUSTOMER DRAWING



AMPMODU 2mm RASTER, CRIMPKONTAKT

| | | | |
|------|-----------|------------|---------------|
| SIZE | CAGE CODE | DRAWING NO | RESTRICTED TO |
| A3 | 00779 | C-969047 | - |

| PROPOSAL-NR. | BENENNUNG EINZELTEIL | WERKSTOFF | OBERFLÄCHE FARBE |
|--------------|-----------------------------------|-----------|---|
| 969 047-8 | CRIMPKONTAKT FÜR ANSCHLAGMASCHINE | CuNiSi | PLAIN/BLANK |
| 969 047-7 | CRIMPKONTAKT FÜR HANDZANGE | CuNiSi | PLAIN/BLANK |
| 969 047-4 | CRIMPKONTAKT FÜR HANDZANGE | CuNiSi |  |
| 969 047-3 | CRIMPKONTAKT FÜR ANSCHLAGMASCHINE | CuNiSi |  |

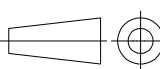
| | |
|---|---|
| DIMENSIONS: mm | TOLERANCES UNLESS OTHERWISE SPECIFIED: DIN ISO 8015 DIN ISO 2768-mk |
|  | 0 PLC ± - 1 PLC ± - 2 PLC ± - 3 PLC ± - 4 PLC ± - ANGLES ± - |
| MATERIAL SEE TABLE | FINISH SEE TABLE |

| | | |
|-------|--------|-----|
| SCALE | SHEET | REV |
| 10:1 | 1 OF 1 | A4 |

单击下面可查看定价，库存，交付和生命周期等信息

[>>TE Connectivity\(泰科\)](#)