

REVISIONS					
P	LTR	DESCRIPTION	DATE	DWN	APVD
	D	REV PER ECR 05-018837	28DEC05	JR	TM
	D1	REVISED PER ECO-17-006294	10OCT2017	RS	DR

- 1 FOR $\phi 9.398$ [$\phi.370$] MAX WIRE INSULATION.
- 2 MATERIAL: BODY; COPPER PER ASTM B152 INSULATION; NYLON COLOR; BLACK
- 3 FINISH: BODY; TIN PL. PER ASTM B545.
- 4 NOTE DELETED.

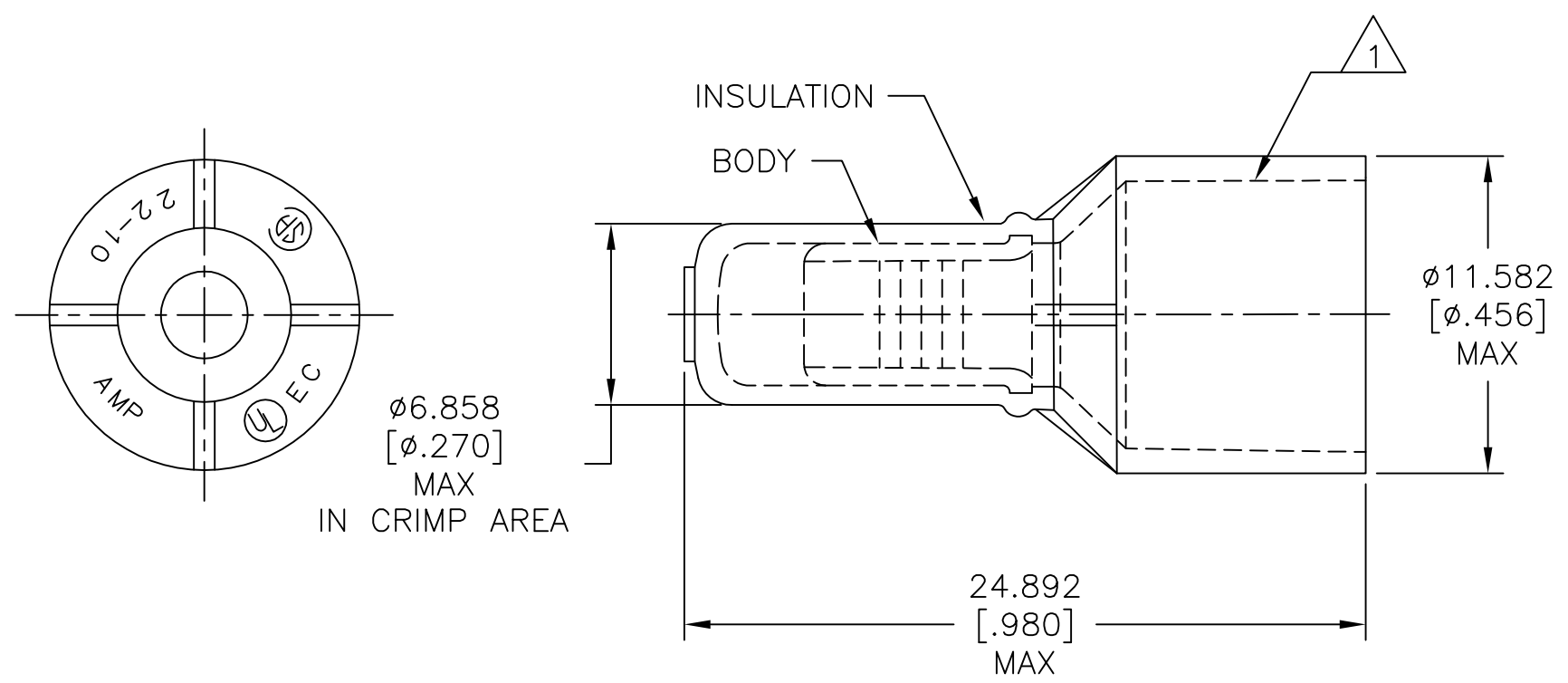

AMP WIRE RANGE	Listed	LR7189 Certified
22-10 AWG SOLID OR STRANDED	22-10 AWG SOLID OR STRANDED	22-10 AWG SOLID OR STRANDED

1000	LOOSE PIECE	55929-1
QTY	DESCRIPTION	PART NO

AMP INCORPORATED CUSTOMER SERVICE SYSTEMS		MAX RECOMMENDED OPERATING TEMPERATURE: 150° C [302°F] MAX	THIS DRAWING IS A CONTROLLED DOCUMENT.		DWN LEMUEL OLMEDA 3/10/93	TE Connectivity			
FOR ADDITIONAL PRODUCT INFORMATION OR COPIES OF DRAWINGS AND TECHNICAL DOCUMENTS	PRODUCT INFORMATION CENTER 1-800-522-6752	VOLTAGE RATING: 600V MAX (BUILDING & WIRING) 1000V MAX (FIXTURES & SIGNS)	DIMENSIONS: mm [INCHES]	TOLERANCES UNLESS OTHERWISE SPECIFIED:	CHK R HERSEY 1/6/94				NAME M ELLIS
FOR APPLICATION TOOLING INFORMATION	TOOLING ASSISTANCE CENTER 1-800-722-1111	CIRCULAR MIL AREA: 1.65-6.64mm ² [3248-13100] SOLID OR STRANDED		0 PLC ± - 1 PLC ± - 2 PLC ± - 3 PLC ± 0.127[.005] 4 PLC ± - ANGLES ± -	APVD M ELLIS 1/6/94	PRODUCT SPEC UL 486 C			
FOR ORDER ENTRY	1-800-526-5142	THIS DRAWING IS A CONTROLLED DOCUMENT FOR AMP INCORPORATED. IT IS SUBJECT TO CHANGE AND THE CONTROLLING ENGINEERING ORGANIZATION SHOULD BE CONTACTED FOR THE LATEST REVISION.	MATERIAL	FINISH	APPLICATION SPEC -	SIZE A3	CAGE CODE 00779	DRAWING NO C-55929	RESTRICTED TO -
CUSTOMER DRAWING					WEIGHT -	SCALE 4:1	SHEET 1 OF 1	REV D1	

单击下面可查看定价，库存，交付和生命周期等信息

[>>TE Connectivity\(泰科\)](#)