

THIS DRAWING IS UNPUBLISHED. RELEASED FOR PUBLICATION
 © COPYRIGHT - BY TYCO ELECTRONICS CORPORATION. ALL RIGHTS RESERVED.

LOC	DIST	REVISIONS				
P	LTR	DESCRIPTION	DATE	DWN	APVD	
GP	00	0	RELEASED PER EC 0S13-0207-05	22JUN05	RR	JG

- 1 . MUST BE USED WITH PART NUMBER 5206473.
- 2 ZINC PLATED .000200-.000400 THICK, CLEAR CHROMATE COATING.
- 3 UNDERCUT MAY OR MAY NOT BE PRESENT IN THIS AREA.

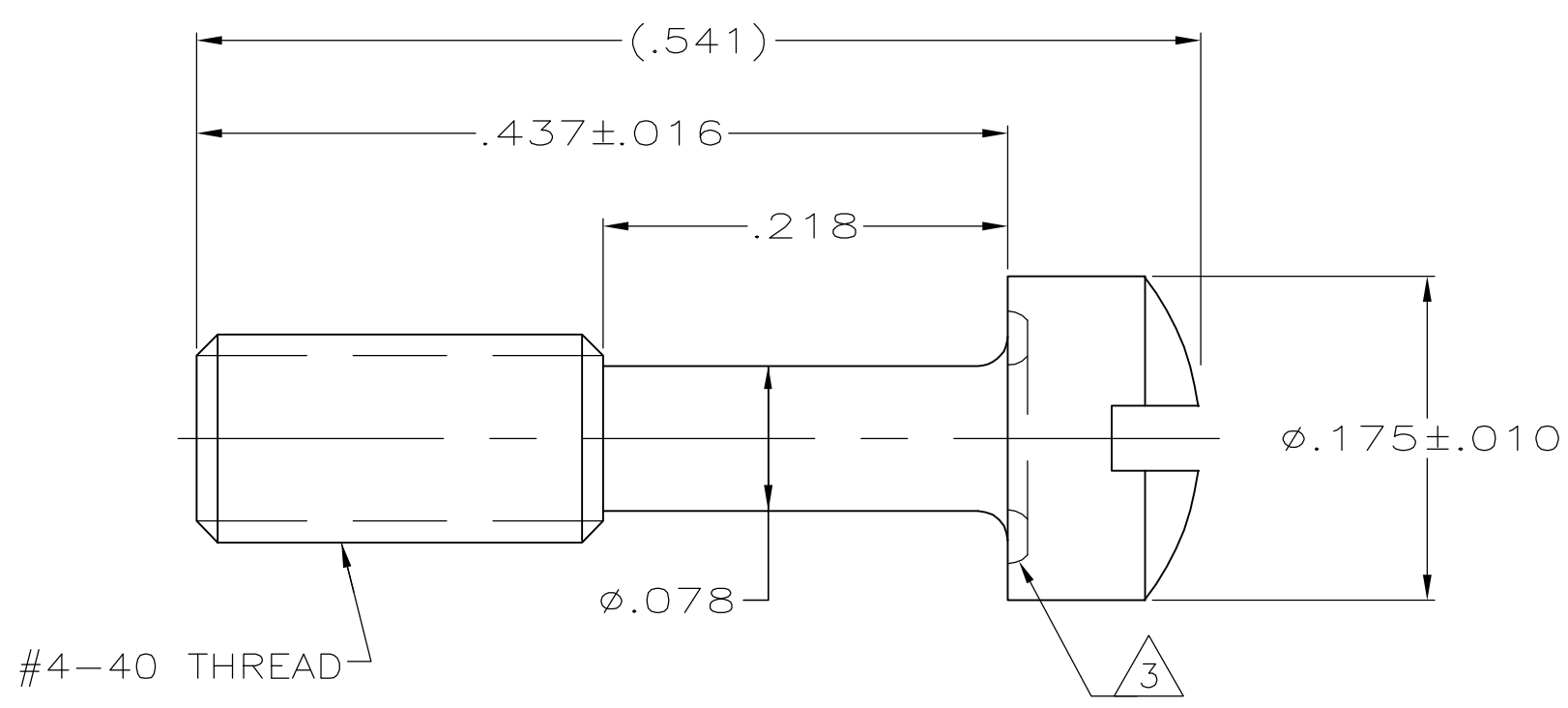

2	5206052-3
FINISH	PART NUMBER

THIS DRAWING IS A CONTROLLED DOCUMENT.		DWN R.RICHARDSON 22JUN05	Tyco Electronics Corporation Harrisburg, Pa 17105-3608														
DIMENSIONS: INCHES		CHK C.ROHDE 22JUN05															
TOLERANCES UNLESS OTHERWISE SPECIFIED:		APVD M.WALMSLEY 22JUN05	NAME SADDLE SCREW, AMPLIMITE														
<table border="0"> <tr><td>0 PLC</td><td>± -</td></tr> <tr><td>1 PLC</td><td>± -</td></tr> <tr><td>2 PLC</td><td>± -</td></tr> <tr><td>3 PLC</td><td>± .005</td></tr> <tr><td>4 PLC</td><td>± -</td></tr> <tr><td>ANGLES</td><td>± -</td></tr> </table>		0 PLC	± -	1 PLC	± -	2 PLC	± -	3 PLC	± .005	4 PLC	± -	ANGLES	± -	PRODUCT SPEC -	APPLICATION SPEC -		
0 PLC	± -																
1 PLC	± -																
2 PLC	± -																
3 PLC	± .005																
4 PLC	± -																
ANGLES	± -																
MATERIAL COLD ROLLED STEEL	FINISH SEE TABLE	WEIGHT -	SIZE A3	CAGE CODE 00779	DRAWING NO C-5206052	RESTRICTED TO -											
CUSTOMER DRAWING			SCALE 10:1	SHEET 1 OF 1	REV 0												

单击下面可查看定价，库存，交付和生命周期等信息

[>>TE Connectivity\(泰科\)](#)