

THIS DRAWING IS UNPUBLISHED. RELEASED FOR PUBLICATION  
 © COPYRIGHT BY TYCO ELECTRONICS CORPORATION. ALL RIGHTS RESERVED.

LOC	DIST	REVISIONS			
P	LTR	DESCRIPTION	DATE	DWN	APVD
G	14	A1	REV PER ECR 07-016469	18JUL07	JR TM

**AMP**  
WIRE RANGE

---

12-10 AWG  
STRANDED

- 1 WIRE INSULATION DIA .150 TO .220.
- 2 FINISH: BODY AND SLEEVE:  
TIN PLATE PER ASTM B545.
- 3 MATERIAL: BODY AND SLEEVE,  
COPPER PER ASTM B152  
INSULATION: PVF<sup>2</sup>  
COLOR- NATURAL

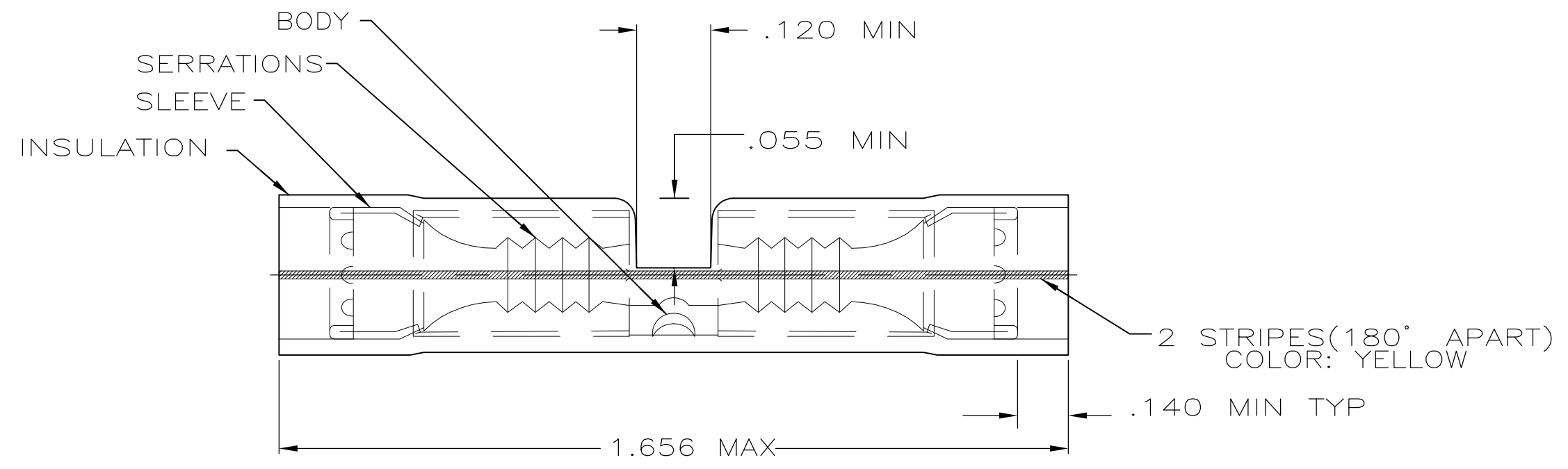

M7928/6-5 CLASS 2	500	LOOSE PIECE	696429-1
MILITARY P/N & CLASS	QTY	PACKAGE TYPE	PART NO.

<b>AMP INCORPORATED CUSTOMER SERVICE SYSTEMS</b>		MAX RECOMMENDED OPERATING TEMPERATURE: 150°C
FOR ADDITIONAL PRODUCT INFORMATION OR COPIES OF DRAWINGS AND TECHNICAL DOCUMENTS	PRODUCT INFORMATION CENTER 1-800-522-6752	VOLTAGE RATING: -
FOR APPLICATION TOOLING INFORMATION	TOOLING ASSISTANCE CENTER 1-800-722-1111	CIRCULAR MIL AREA: 2.62-6.64mm <sup>2</sup> [5,180-13,100] STRANDED
FOR ORDER ENTRY	1-800-526-5142	THIS DRAWING IS A CONTROLLED DOCUMENT FOR AMP INCORPORATED. IT IS SUBJECT TO CHANGE AND THE CONTROLLING ENGINEERING ORGANIZATION SHOULD BE CONTACTED FOR THE LATEST REVISION.

THIS DRAWING IS A CONTROLLED DOCUMENT.	
DIMENSIONS: INCHES	TOLERANCES UNLESS OTHERWISE SPECIFIED:
	0 PLC ± -
	1 PLC ± -
	2 PLC ± .008
	3 PLC ± -
	4 PLC ± -
	ANGLES ± -
MATERIAL	FINISH
- 3	- 2

DWN JR RUTH 19AUG05	Tyco Electronics Corporation Harrisburg, Pa 17105-3608	
CHK T MICHIELUTTI 19AUG05	NAME SPLICE, BUTT, PVF2 , P.I.D.G. WIRE SIZE: 12-10 AWG	
APVD T MICHIELUTTI 19AUG05	PRODUCT SPEC	APPLICATION SPEC
PRODUCT SPEC	SIZE	CAGE CODE
APPLICATION SPEC	WEIGHT	DRAWING NO
RESTRICTED TO	A3 00779 C-696429	
CUSTOMER DRAWING	SCALE 1:1	SHEET 1 OF 1
REV A1		

单击下面可查看定价，库存，交付和生命周期等信息

[>>TE Connectivity\(泰科\)](#)