

REVISIONS					
P	LTR	DESCRIPTION	DATE	DMN	APVD
G		REVISED PER ECO-15-015252	13NOV15	BJ	FY

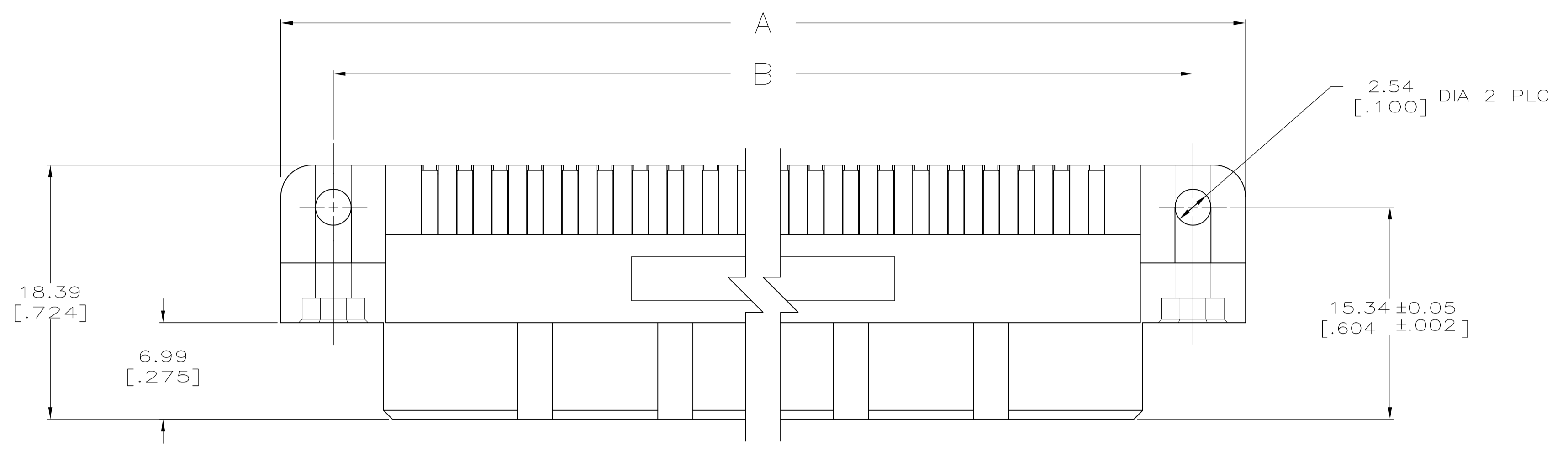

- 1 HOUSING MATERIAL: THERMOPLASTIC, COLOR: BLACK
- 2 CONTACT MATERIAL: COPPER ALLOY
- 3 FINISH:
MATING AREA: MEETS THE PERFORMANCE REQUIREMENTS OF PRODUCT SPECIFICATION 108-9063; BASED ON TELCORDIA DR-1217-CORE APPLICATIONS IN UNCONTROLLED ENVIRONMENTS.
SOLDER TAILS AREA: TIN-LEAD PLATED.
- 4 SOLDER TAILS MUST FIT HOLE PATTERN AS SHOWN ON THE RECOMMENDED P.C. BOARD LAYOUT
- 5 HOUSINGS WITH CENTER MOUNTING IS RECOMMENDED FOR ASSEMBLIES HAVING 75 CONTACTS PER ROW OR MORE
- 6 SEE SHEET 2 FOR LOADING PATTERN AND P.C. BOARD LAYOUT

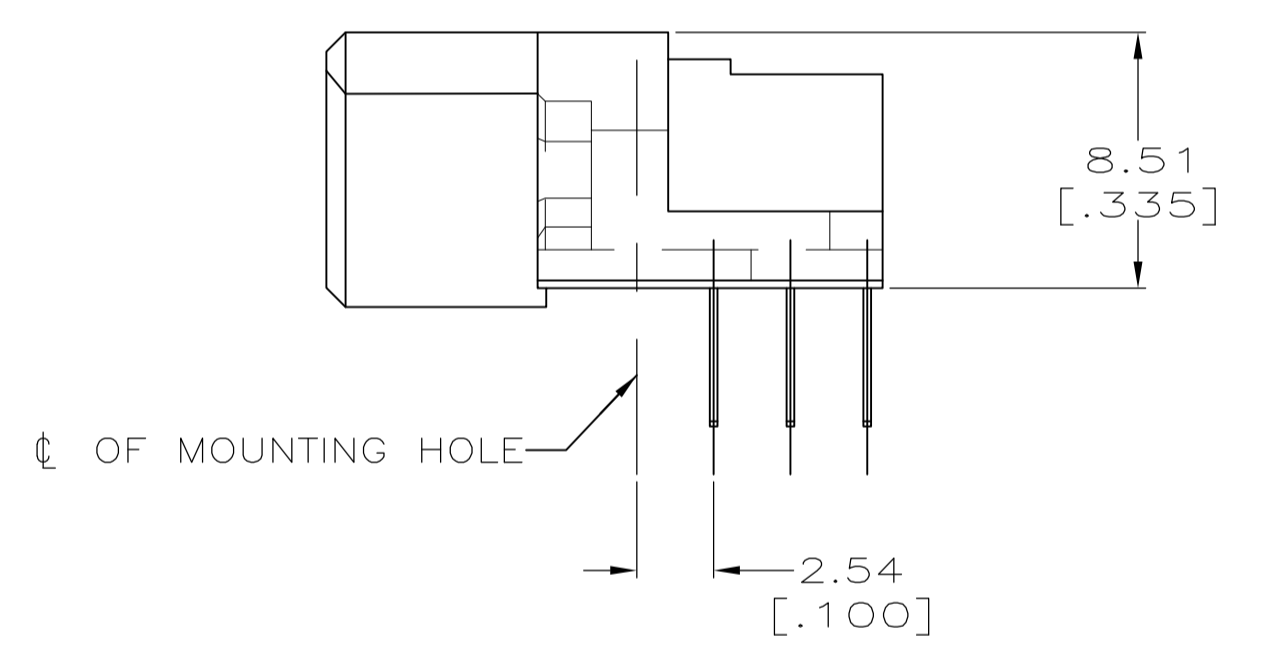
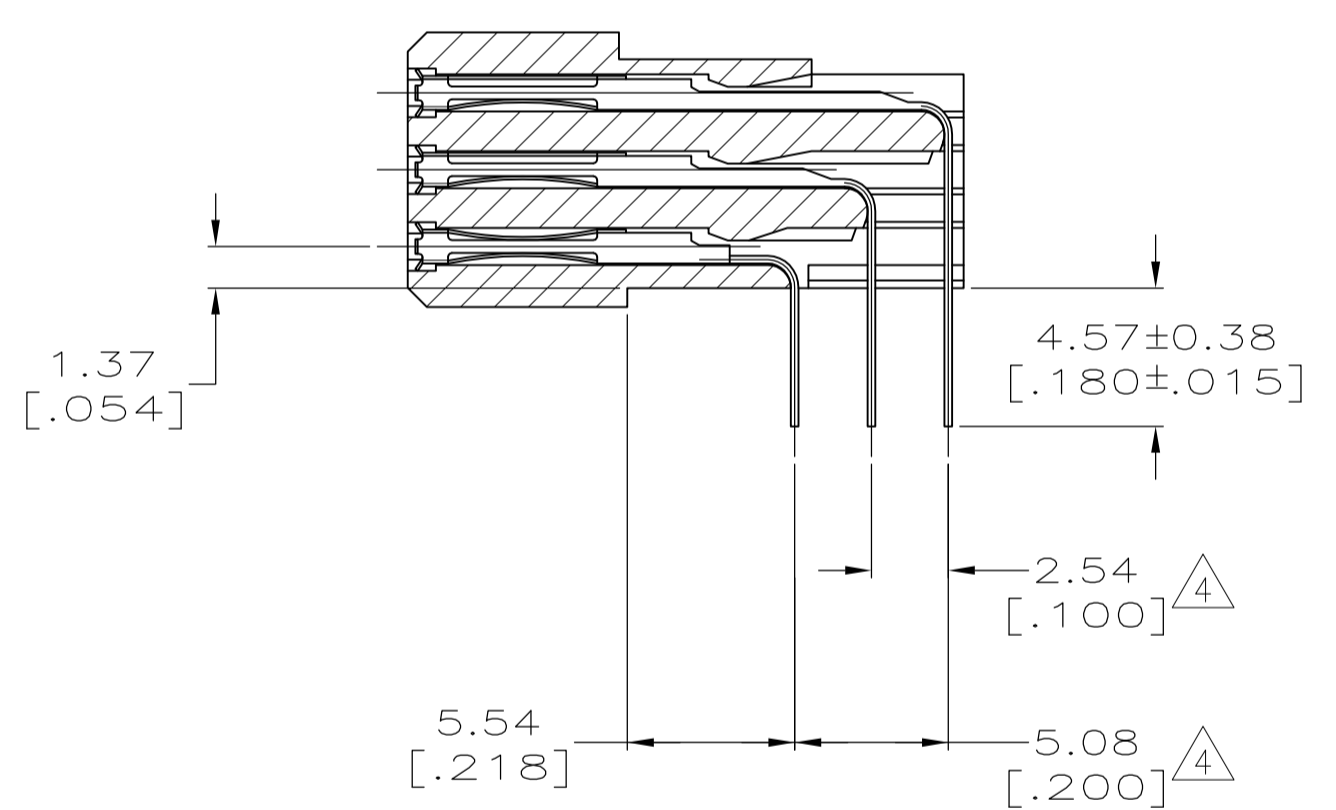
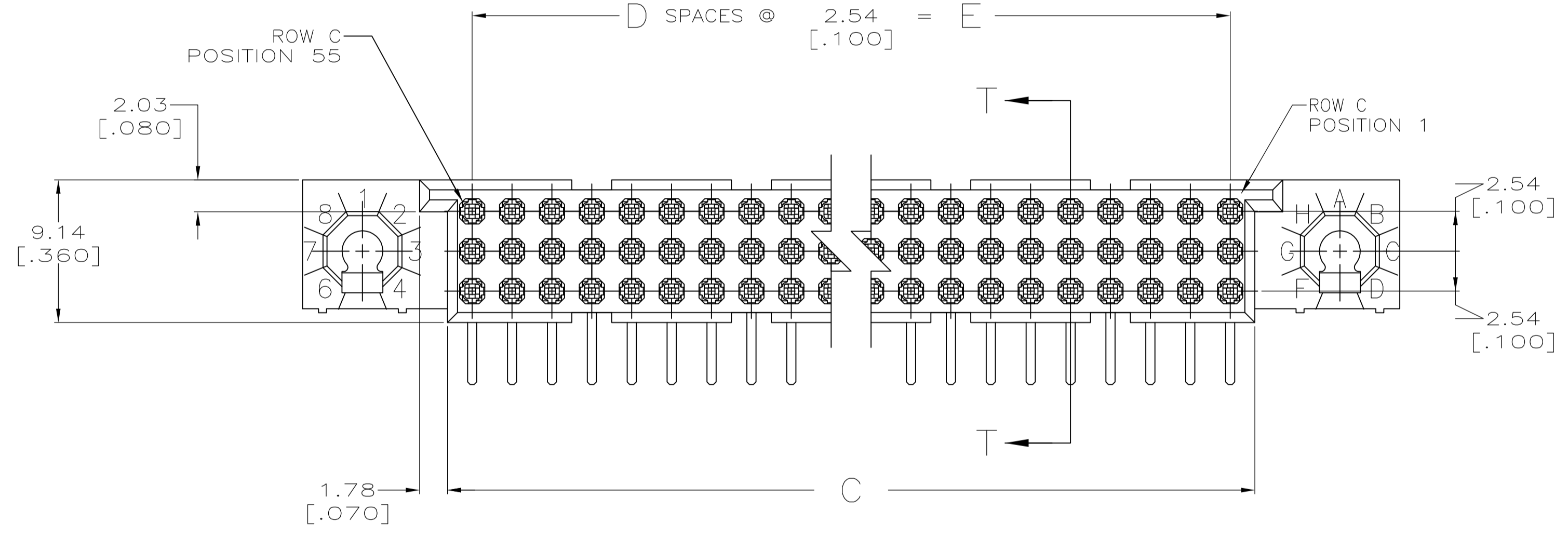

SECTION T-T

OBSELETE	137.16 [5.400]	54	140.31 [5.524]	151.13 [5.950]	158.75 [6.250]	69	532834-2
	137.16 [5.400]	54	140.31 [5.524]	151.13 [5.950]	158.75 [6.250]	107	532834-1
	E	D	C	B	A	POSITION	PART NUMBER

THIS DRAWING IS A CONTROLLED DOCUMENT.

DK SCHRUM 23JUL2003
CHK WI MILLHIMES 23JUL2003
APVD WI MILLHIMES 23JUL2003

STE TE Connectivity

NAME: HDI, 3 ROW, RECEPTACLE ASSEMBLY, SPECIAL LOADING

PRODUCT SPEC: ---
APPLICATION SPEC: ---

SIZE: A1 CAGE CODE: 00779 DRAWING NO: 532834
WEIGHT: 0

MATERIAL: 1/2 FINISH: 3

CUSTOMER DRAWING SCALE: 4:1 SHEET: 1 OF 2 REV: G

REVISIONS				
P	LTR	DESCRIPTION	DATE	APPV
-	-	SEE SHEET 1	-	-

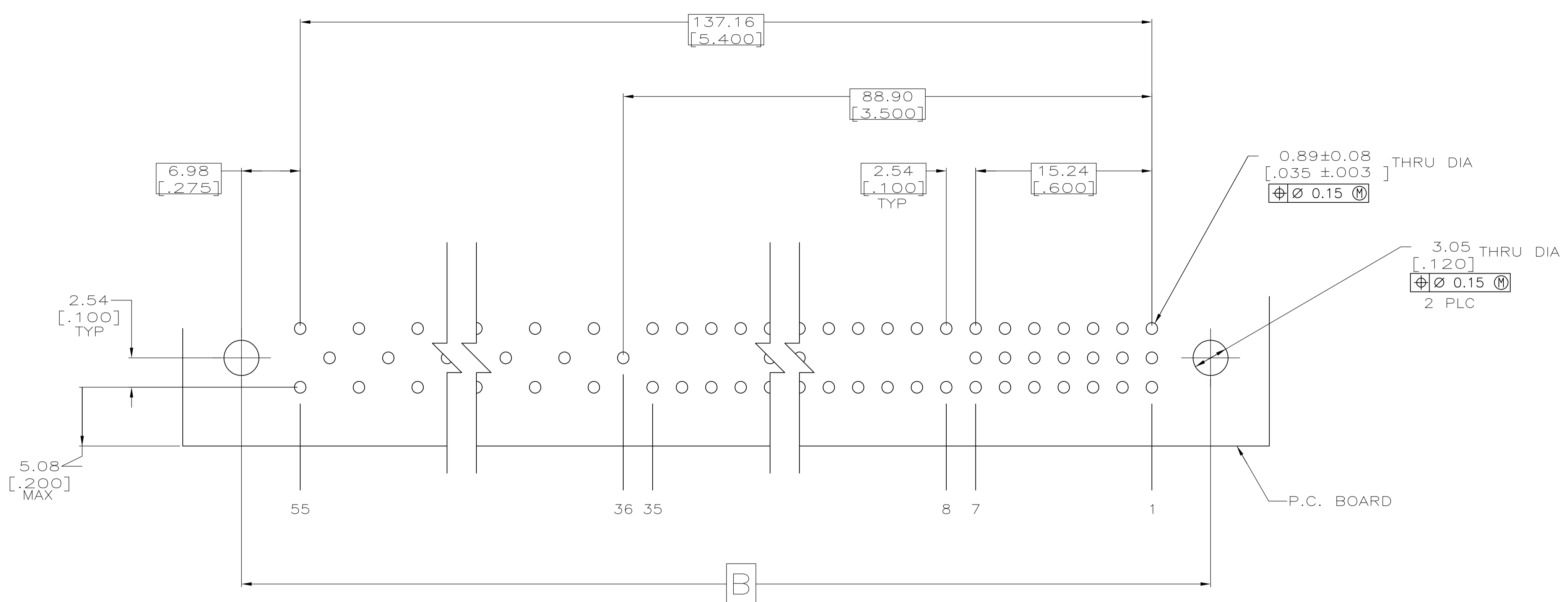

RECOMMENDED P.C. BOARD LAYOUT
CONNECTOR SIDE DOWN
P/N 532834-1

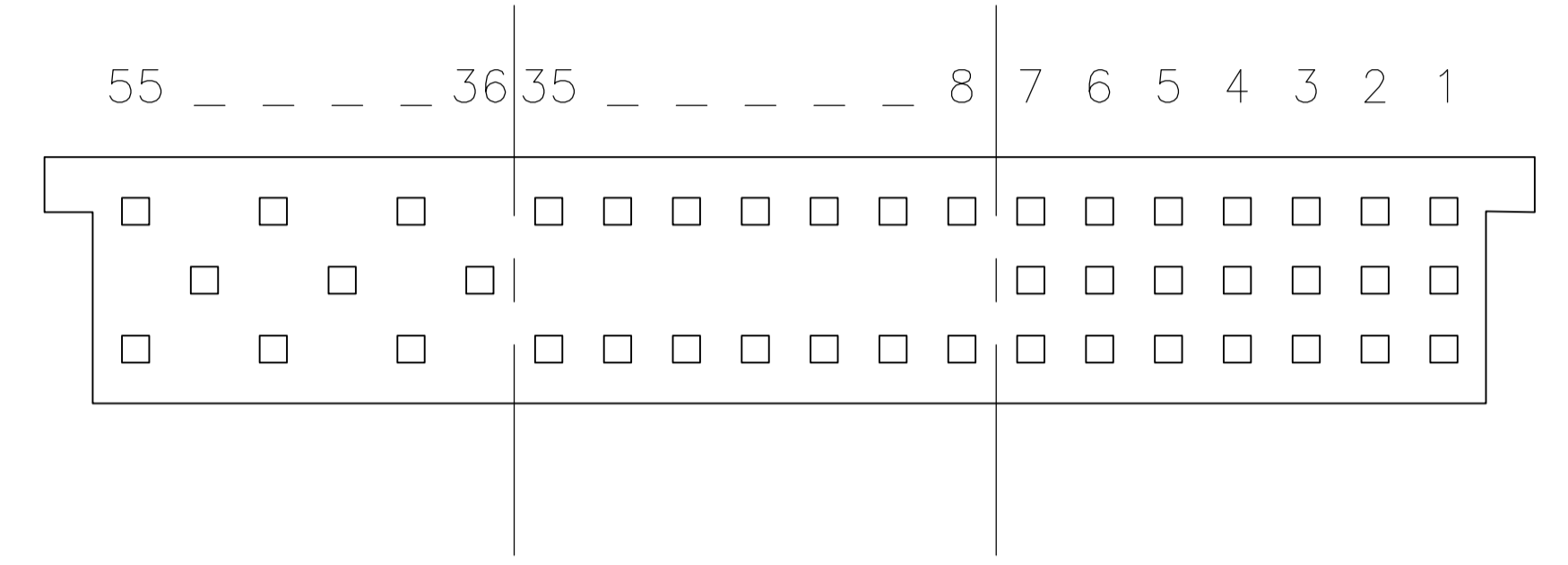

CONTACT LOADING PATTERN
107 CONTACTS
P/N 532834-1

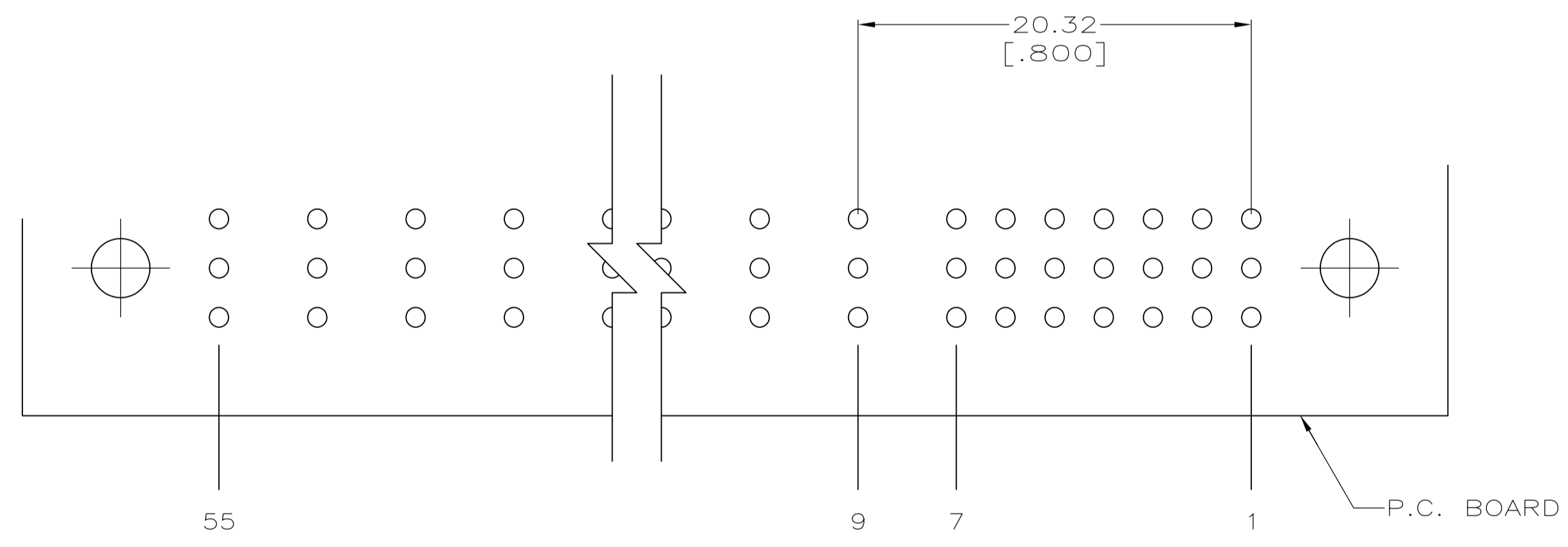

RECOMMENDED P.C. BOARD LAYOUT
CONNECTOR SIDE DOWN
P/N 532834-2
(DIMENSIONS SAME AS ABOVE)

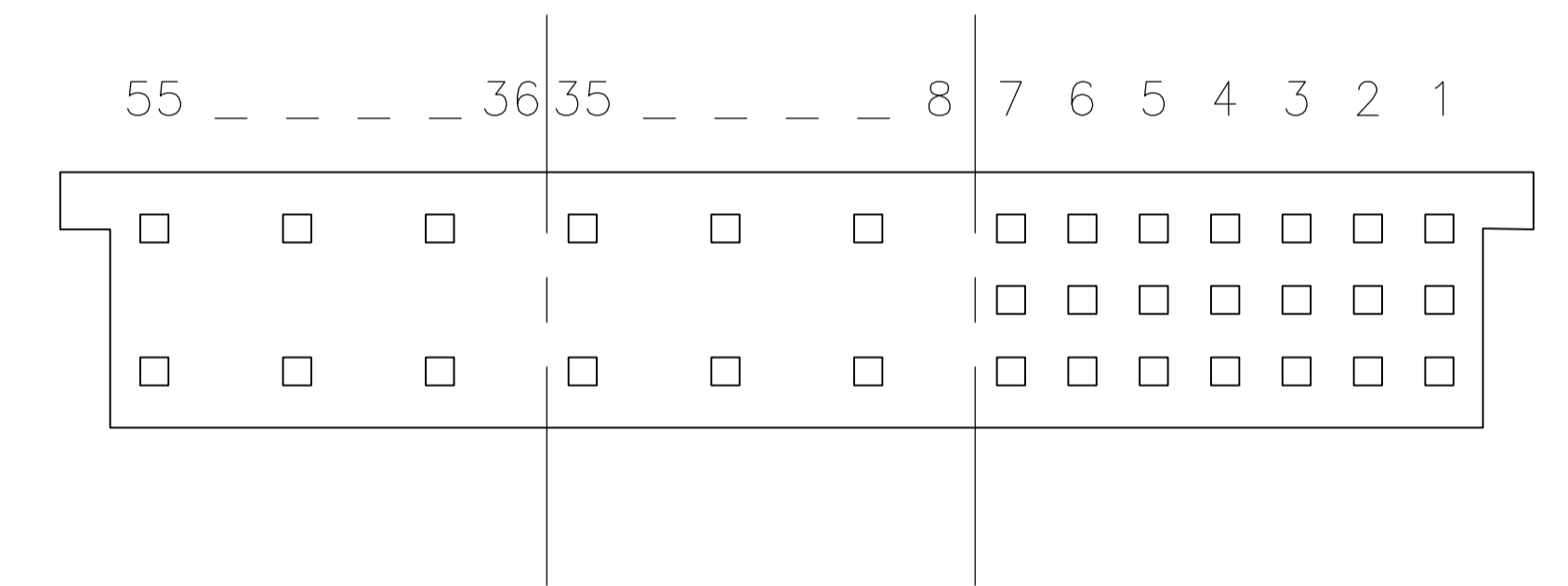

CONTACT LOADING PATTERN
69 CONTACTS
P/N 532834-2

THIS DRAWING IS A CONTROLLED DOCUMENT.		DIN DK SCHRUM 23JUL2003		TE Connectivity	
DIMENSIONS: mm		TOLERANCES UNLESS OTHERWISE SPECIFIED:			
0 PLC ± - 1 PLC ± - 2 PLC ± 0.13[.005] 3 PLC ± - 4 PLC ± - ANGLES ± -		APVD WI MILLHIMES 23JUL2003 PRODUCT SPEC APPLICATION SPEC		SIZE: A1 CAGE CODE: 00779 DRAWING NO: 532834	
MATERIAL:		FINISH:		WEIGHT: 0 CUSTOMER DRAWING: SCALE: 4:1 SHEET 2 OF 2 REV G	

单击下面可查看定价，库存，交付和生命周期等信息

[>>TE Connectivity\(泰科\)](#)