

THIS DRAWING IS UNPUBLISHED. RELEASED FOR PUBLICATION  
 © COPYRIGHT - By - ALL RIGHTS RESERVED.

LOC		DIST		REVISIONS			
P	LTR	DESCRIPTION		DATE	DWN	APVD	
	G2	REVISED PER ECO-13-005696		24JUL13	KH	MM	

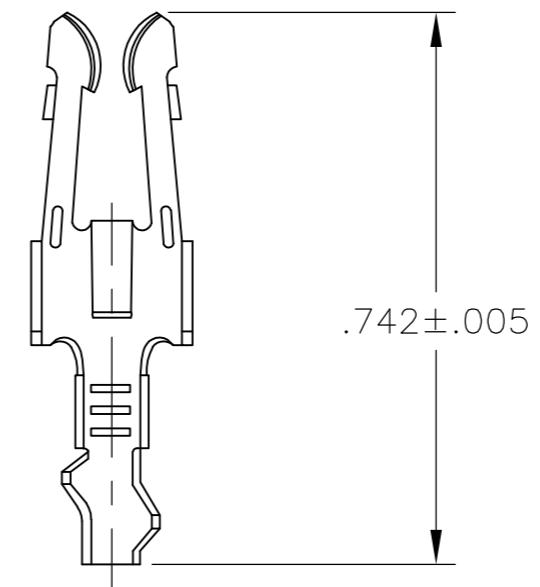
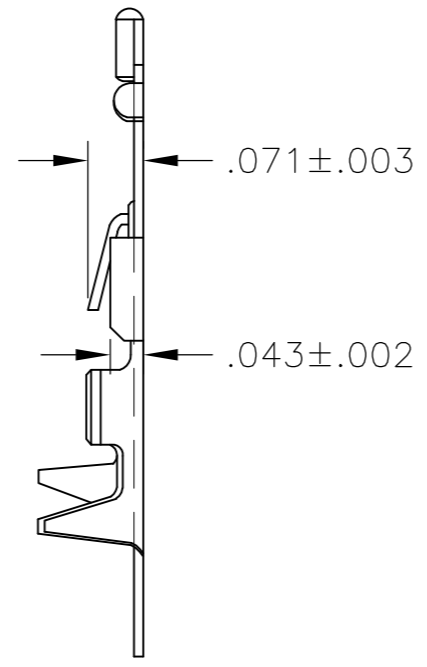
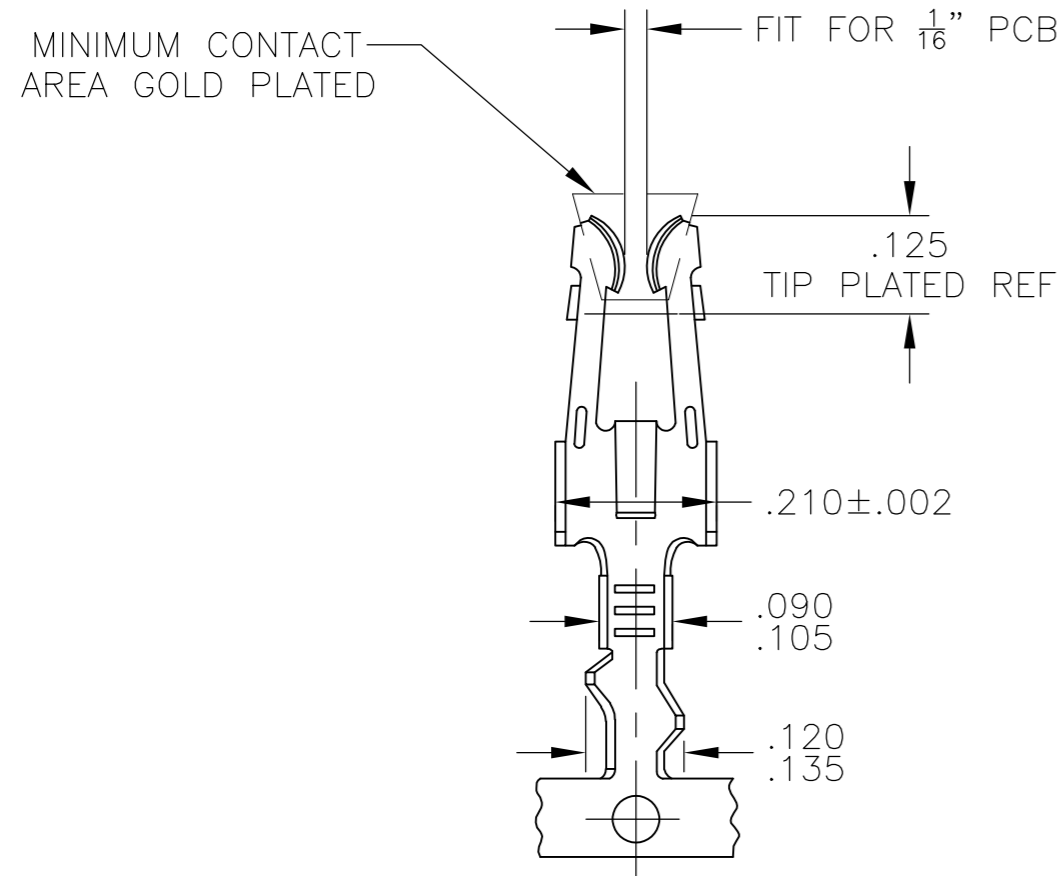

LOOSE PIECE

1. WIRE SIZE: #24-#20 AWG.  
INS. RANGE : .050-.090 DIA
- MATTE TIN PLATE IN CRIMP AREA.  
 OBSOLETE PARTS: OBSOLETE CIS STREAMLINING PER D.RENAUD/D.SINISI

	NICKEL PLATE ALL OVER, TIP PLATE .000015 THICK GOLD.REELING L-R FEED FOR MINI-APPLICATOR.	5-583261-3	5-583259-4
	NICKEL PLATE ALL OVER, TIP PLATE .000015 THICK GOLD.REELING L-R FEED FOR MINI-APPLICATOR.	5-583261-2	5-583259-3
	TIN REELING L-R FEED FOR MINI APPLICATOR.	5-583261-1	5-583259-2
OBSOLETE	TIN REELING L-R FEED FOR STRIPPER CRIMPER.	583261-2	-583259-5-
	NICKEL PLATE ALL OVER, TIP PLATE .000015 THICK GOLD.REELING L-R FEED FOR MINI-APPLICATOR.	583261-3	583259-4
	NICKEL PLATE ALL OVER, TIP PLATE .000015 THICK GOLD.REELING L-R FEED FOR MINI-APPLICATOR.	583261-2	583259-3
OBSOLETE	TIN REELING L-R FEED FOR MINI APPLICATOR.	583261-1	-583259-2-
	FINISH	LOOSE PIECE PART NO.	PART NO.

THIS DRAWING IS A CONTROLLED DOCUMENT.		DWN	-	TE Connectivity																			
		CHK	-																				
DIMENSIONS: INCHES		APVD	-	NAME																			
TOLERANCES UNLESS OTHERWISE SPECIFIED:		PRODUCT SPEC		MODIFIED FORK CONTACT																			
<table border="0"> <tr><td>0 PLC</td><td>±</td><td>-</td></tr> <tr><td>1 PLC</td><td>±</td><td>-</td></tr> <tr><td>2 PLC</td><td>±</td><td>-</td></tr> <tr><td>3 PLC</td><td>±</td><td>-</td></tr> <tr><td>4 PLC</td><td>±</td><td>-</td></tr> <tr><td>ANGLES</td><td>±</td><td>-</td></tr> </table>		0 PLC	±	-	1 PLC	±	-	2 PLC	±	-	3 PLC	±	-	4 PLC	±	-	ANGLES	±	-	APPLICATION SPEC		RESTRICTED TO	
0 PLC	±	-																					
1 PLC	±	-																					
2 PLC	±	-																					
3 PLC	±	-																					
4 PLC	±	-																					
ANGLES	±	-																					
MATERIAL	FINISH	WEIGHT	-	SIZE	CAGE CODE																		
PHOS. BRONZE	SEE TABLE			A2	00779																		
		CUSTOMER DRAWING		DRAWING NO	583259																		
		SCALE	4:1	SHEET	1 of 1																		
				REV	G2																		

单击下面可查看定价，库存，交付和生命周期等信息

[>>TE Connectivity\(泰科\)](#)