

THIS DRAWING IS UNPUBLISHED. RELEASED FOR PUBLICATION - N/A .
 © COPYRIGHT N/A By - ALL RIGHTS RESERVED.

LOC	DIST	REVISIONS					
AD	25	P	LTR	DESCRIPTION	DATE	DWN	APVD
		L		REV PER ECO-12-009804	22JUN12	PY	DM

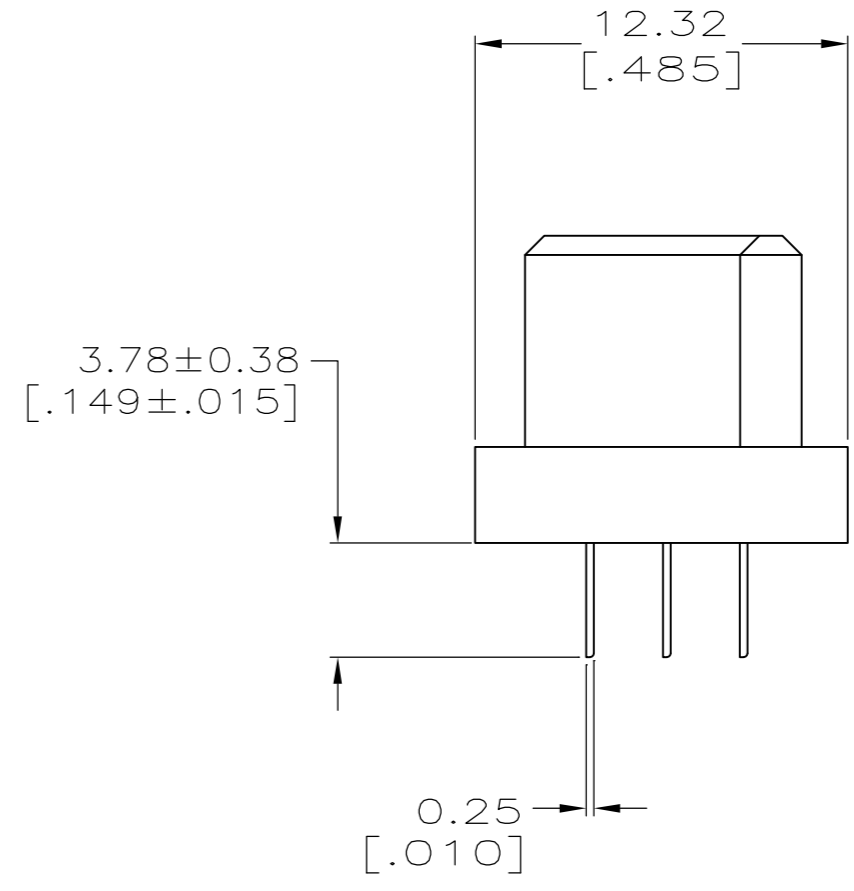
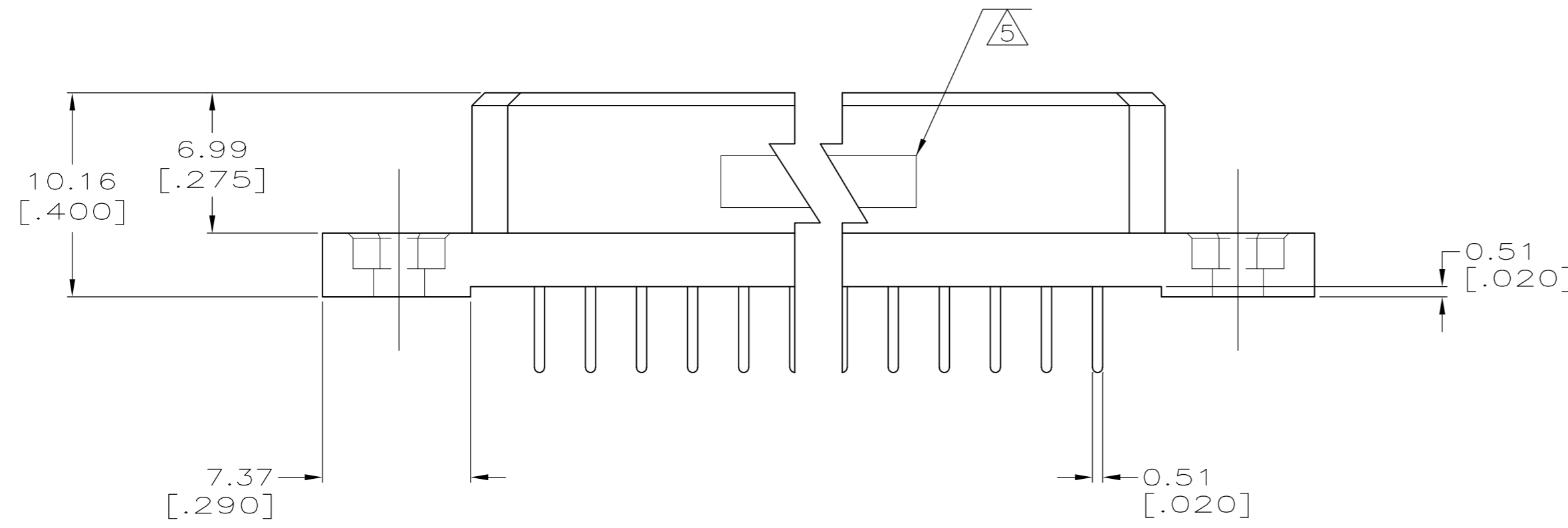
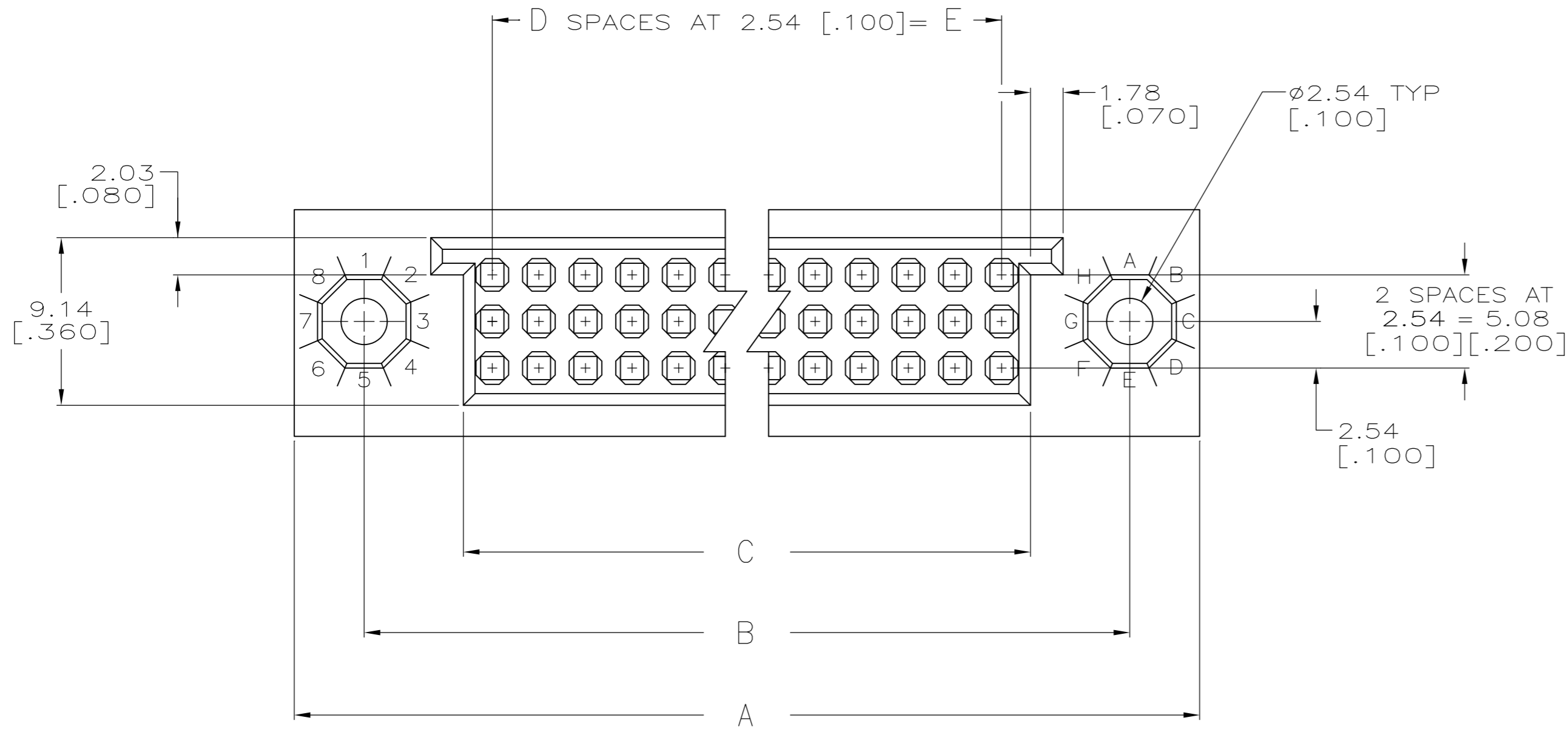

THIS DRAWING IS A CONTROLLED DOCUMENT.		DWN R. SEIFRIED 10-OCT-84	STE TE Connectivity	
DIMENSIONS: mm [INCHES]		CHK D. RUBENDALL 10-OCT-84		
TOLERANCES UNLESS OTHERWISE SPECIFIED:		APVD D. RUBENDALL 10-OCT-84	NAME D. RUBENDALL	
0 PLC ± -		PRODUCT SPEC	BOX II ASSEMBLY	
1 PLC ± -		APPLICATION SPEC	3 ROW WITH	
2 PLC ± -		WEIGHT	3.78 [.149] SOLDER TAILS	
3 PLC ± 0.13 [.005]		SCALE	SIZE	CAGE CODE
4 PLC ± -		4:1	A2	00779
ANGLES ± -		SHEET	DRAWING NO	
FINISH		1 OF 2	C=533287	
1 - 2		REV	RESTRICTED TO	
- 3		L	-	
CUSTOMER DRAWING		SCALE 4:1 SHEET 1 OF 2 REV L		

533287

THIS DRAWING IS UNPUBLISHED. RELEASED FOR PUBLICATION - N/A .
 © COPYRIGHT N/A By - ALL RIGHTS RESERVED.

LOC	DIST	REVISIONS					
		P	LTR	DESCRIPTION	DATE	DWN	APVD
AD	25	-	-	SEE SHEET 1	-	-	-

- ① HOUSING MATERIAL: THERMOPLASTIC, COLOR - NATURAL (BROWN).
- ② CONTACT MATERIAL: BERYLLIUM COPPER OR COPPER-NICKEL-SILICON PER UNS C70260.
- ③ CONTACT FINISH: 0.00127-0.00254 [.000050-.000100] NICKEL UNDERPLATE ALL OVER, 0.000762 [.000030] GOLD IN CONTACT AREA. TIN-LEAD PLATED SOLDER TAILS.
- 4. DIMENSIONS IN BRACKETS ARE IN INCHES.
- ⑤ TE, PART NO. & DATE CODE MARKED IN THIS APPROXIMATE AREA.
- ⑥ CONTACT FINISH: 0.00127-0.00254 [.000050-.000100] NICKEL UNDERPLATE ALL OVER, 0.000762 [.000030] GOLD IN CONTACT AREA. TIN PLATED SOLDER TAILS.

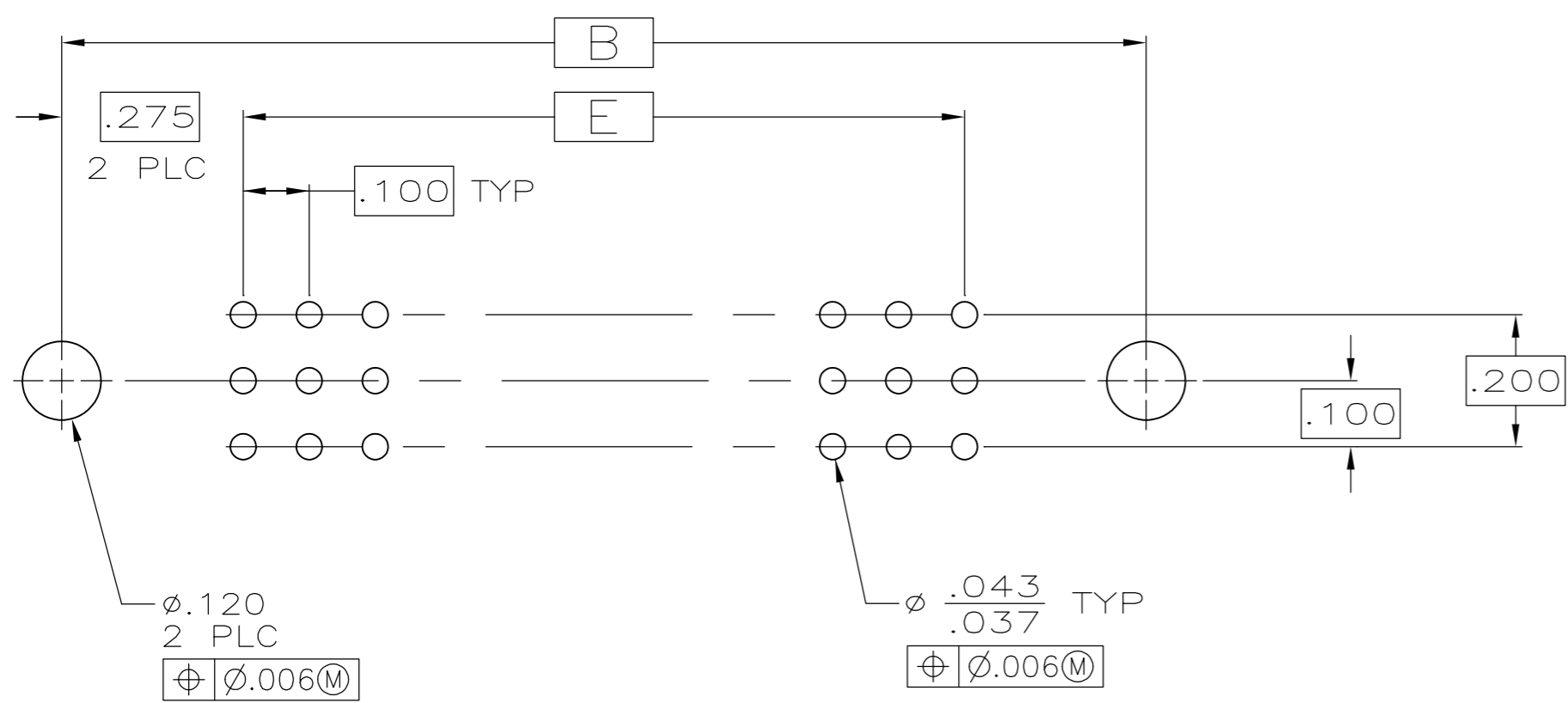

	⑥	124.46 [4.900]	49	127.61 [5.024]	138.43 [5.450]	146.05 [5.750]	150	5-533287-7
	⑥	86.36 [3.400]	34	89.51 [3.524]	100.33 [3.950]	107.95 [4.250]	105	5-533287-4
	⑥	78.74 [3.100]	31	81.89 [3.224]	92.71 [3.650]	100.33 [3.950]	96	5-533287-3
OBSOLETE		144.78 [5.700]	57	147.93 [5.824]	158.75 [6.250]	166.37 [6.550]	174	1-533287-8
	③	251.46 [9.900]	99	254.61 [10.024]	265.43 [10.450]	273.05 [10.750]	300	1-533287-7
	③	238.76 [9.400]	94	234.29 [9.224]	252.73 [9.950]	260.35 [10.250]	285	1-533287-6
	③	226.06 [8.900]	89	229.21 [9.024]	240.03 [9.450]	247.65 [9.750]	270	1-533287-5
	③	213.36 [8.400]	84	216.51 [8.524]	227.33 [8.950]	234.95 [9.250]	255	1-533287-4
OBSOLETE		200.66 [7.900]	79	203.81 [8.024]	214.63 [8.450]	222.25 [8.750]	240	1-533287-3
	③	187.96 [7.400]	74	191.11 [7.524]	201.93 [7.950]	209.55 [8.250]	225	1-533287-2
	③	175.26 [6.900]	69	178.41 [7.024]	189.23 [7.450]	196.85 [7.750]	210	1-533287-1
OBSOLETE		162.56 [6.400]	64	165.71 [6.524]	176.53 [6.950]	184.15 [7.250]	195	1-533287-0
	③	149.86 [5.900]	59	153.01 [6.024]	163.83 [6.450]	171.45 [6.750]	180	533287-9
	③	137.16 [5.400]	54	140.31 [5.524]	151.13 [5.950]	158.75 [6.250]	165	533287-8
	③	124.46 [4.900]	49	127.61 [5.024]	138.43 [5.450]	146.05 [5.750]	150	533287-7
	③	111.76 [4.400]	44	114.91 [4.524]	125.73 [4.950]	133.35 [5.250]	135	533287-6
	③	99.06 [3.900]	39	102.21 [4.024]	113.03 [4.450]	120.65 [4.750]	120	533287-5
	③	86.36 [3.400]	34	89.51 [3.524]	100.33 [3.950]	107.95 [4.250]	105	533287-4
	③	78.74 [3.100]	31	81.89 [3.224]	92.71 [3.650]	100.33 [3.950]	96	533287-3
	③	73.66 [2.900]	29	76.81 [3.024]	87.63 [3.450]	95.25 [3.750]	90	533287-2
	③	60.96 [2.400]	24	64.11 [2.524]	74.93 [2.950]	82.55 [3.250]	75	533287-1
REMARKS		E	D	C	B	A	POS	PART NUMBER

THIS DRAWING IS A CONTROLLED DOCUMENT.

DWN	R. SEIFRIED	10-OCT-84
CHK	D. RUBENDALL	10-OCT-84
APVD	D. RUBENDALL	10-OCT-84

TE Connectivity

BOX II ASSEMBLY
3 ROW WITH
3.78 [.149] SOLDER TAILS

SIZE	A2	CAGE CODE	00779	DRAWING NO	C=533287	RESTRICTED TO	-
SCALE	4:1	SHEET	2 of 2	REV	L		

CUSTOMER DRAWING

单击下面可查看定价，库存，交付和生命周期等信息

[>>TE Connectivity\(泰科\)](#)