

| P | LTR | DESCRIPTION | DATE | DWN | APVD |
|---|-----|---------------------------|-----------|-----|------|
| H | | REV PER ECR 09-025674 | 01DEC09 | JR | TM |
| J | | REVISED PER ECO-17-013200 | 07MAY2018 | RS | DR |

AMP
WIRE RANGE

14-12 AWG
SOLID OR STRANDED

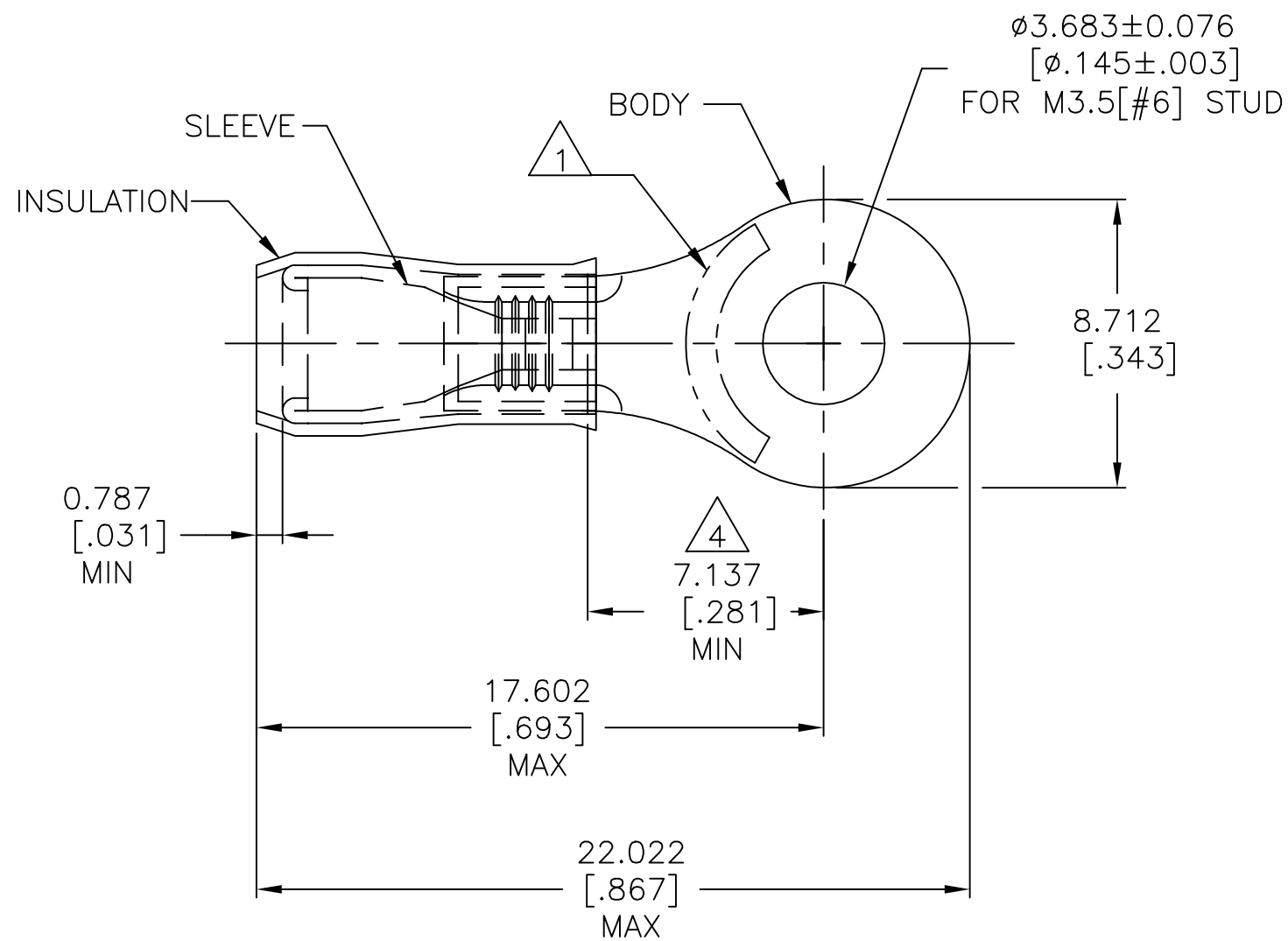

- 1 STAMP AMP 14-12, LOCATION AS SHOWN
- 2 WIRE INSULATION DIA RANGE IS $\phi 2.032 - \phi 3.175 [\phi .080 - \phi .125]$
- 3 BODY MATERIAL THK IS $0.787 \pm 0.051 [.031 \pm .002]$
- 4 APPLIES FROM CENTER OF STUD HOLE TO EDGE OF METAL WIRE BARREL
- 5 MATERIAL:
BODY & SLEEVE - COPPER PER ASTM B-152
INSULATION: NYLON
- 6 FINISH:
BODY & SLEEVE - TIN PLATE PER ASTM B-545
INSULATION: COLOR - WHITE
- 7 MAX RECOMMENDED OPERATING TEMP $105^{\circ}\text{C} [221^{\circ}\text{F}]$
- 8 VOLTAGE RATING: 300 V MAX
- 9 WIRE CROSS SECTIONAL AREA RANGE:
 $1.65 - 3.45 \text{mm}^2 [3,260 - 6,800] \text{ CMA}$

| | | |
|-----|----------------|---------|
| 500 | LOOSE PIECE | 152874 |
| QTY | PACKAGING TYPE | PART NO |

| | | | | | | | | | | | | | | | | |
|--|----------------|----------------------------------|---------------------------------|---------------|-----|-------|-----|-------|----------------|-------|-----|--------|------|--------------|---|--|
| THIS DRAWING IS A CONTROLLED DOCUMENT. | | DWN jr ruth 05MAY06 | STE TE Connectivity Ltd. | | | | | | | | | | | | | |
| DIMENSIONS: mm [INCHES] | | CHK T MICHIELUTTI 05MAY06 | | | | | | | | | | | | | | |
| TOLERANCES UNLESS OTHERWISE SPECIFIED: | | APVD T MICHIELUTTI 05MAY06 | NAME | | | | | | | | | | | | | |
| <table border="0"> <tr><td>0 PLC</td><td>± -</td></tr> <tr><td>1 PLC</td><td>± -</td></tr> <tr><td>2 PLC</td><td>± -</td></tr> <tr><td>3 PLC</td><td>± 0.127 [.005]</td></tr> <tr><td>4 PLC</td><td>± -</td></tr> <tr><td>ANGLES</td><td>± 5°</td></tr> </table> | | 0 PLC | ± - | 1 PLC | ± - | 2 PLC | ± - | 3 PLC | ± 0.127 [.005] | 4 PLC | ± - | ANGLES | ± 5° | PRODUCT SPEC | TERMINAL, RING TONGUE, PIDG, WIRE SIZE 14-12 AWG | |
| 0 PLC | ± - | | | | | | | | | | | | | | | |
| 1 PLC | ± - | | | | | | | | | | | | | | | |
| 2 PLC | ± - | | | | | | | | | | | | | | | |
| 3 PLC | ± 0.127 [.005] | | | | | | | | | | | | | | | |
| 4 PLC | ± - | | | | | | | | | | | | | | | |
| ANGLES | ± 5° | | | | | | | | | | | | | | | |
| MATERIAL | | APPLICATION SPEC | SIZE | CAGE CODE | | | | | | | | | | | | |
| FINISH | | 114-2157 | A3 | 00779 | | | | | | | | | | | | |
| CUSTOMER DRAWING | | WEIGHT | DRAWING NO | RESTRICTED TO | | | | | | | | | | | | |
| | | | C=152874 | - | | | | | | | | | | | | |
| | | SCALE | SHEET | REV | | | | | | | | | | | | |
| | | 5:1 | 1 OF 1 | J | | | | | | | | | | | | |

单击下面可查看定价，库存，交付和生命周期等信息

[>>TE Connectivity\(泰科\)](#)