

THIS DRAWING IS UNPUBLISHED. RELEASED FOR PUBLICATION
 © COPYRIGHT - By - ALL RIGHTS RESERVED.

REVISIONS				
P	LTR	DESCRIPTION	DATE	APVD
M		REVISED PER ECO-16-010037	29JUL2016	AP DG

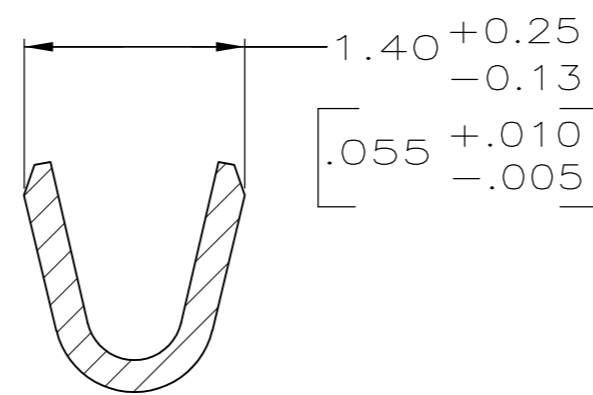
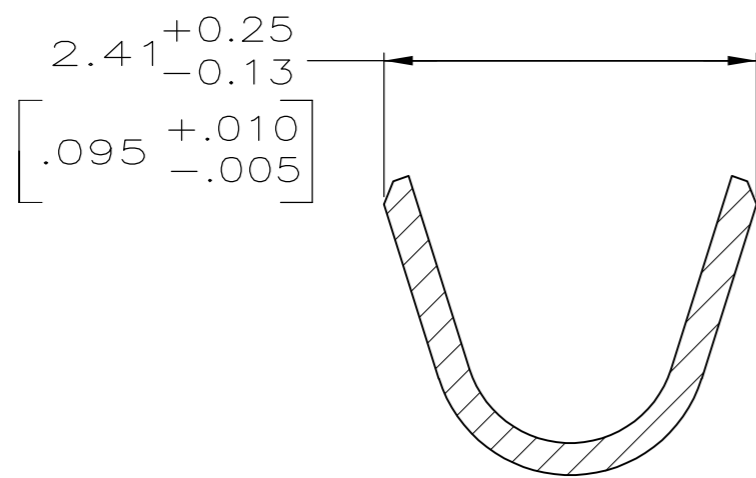
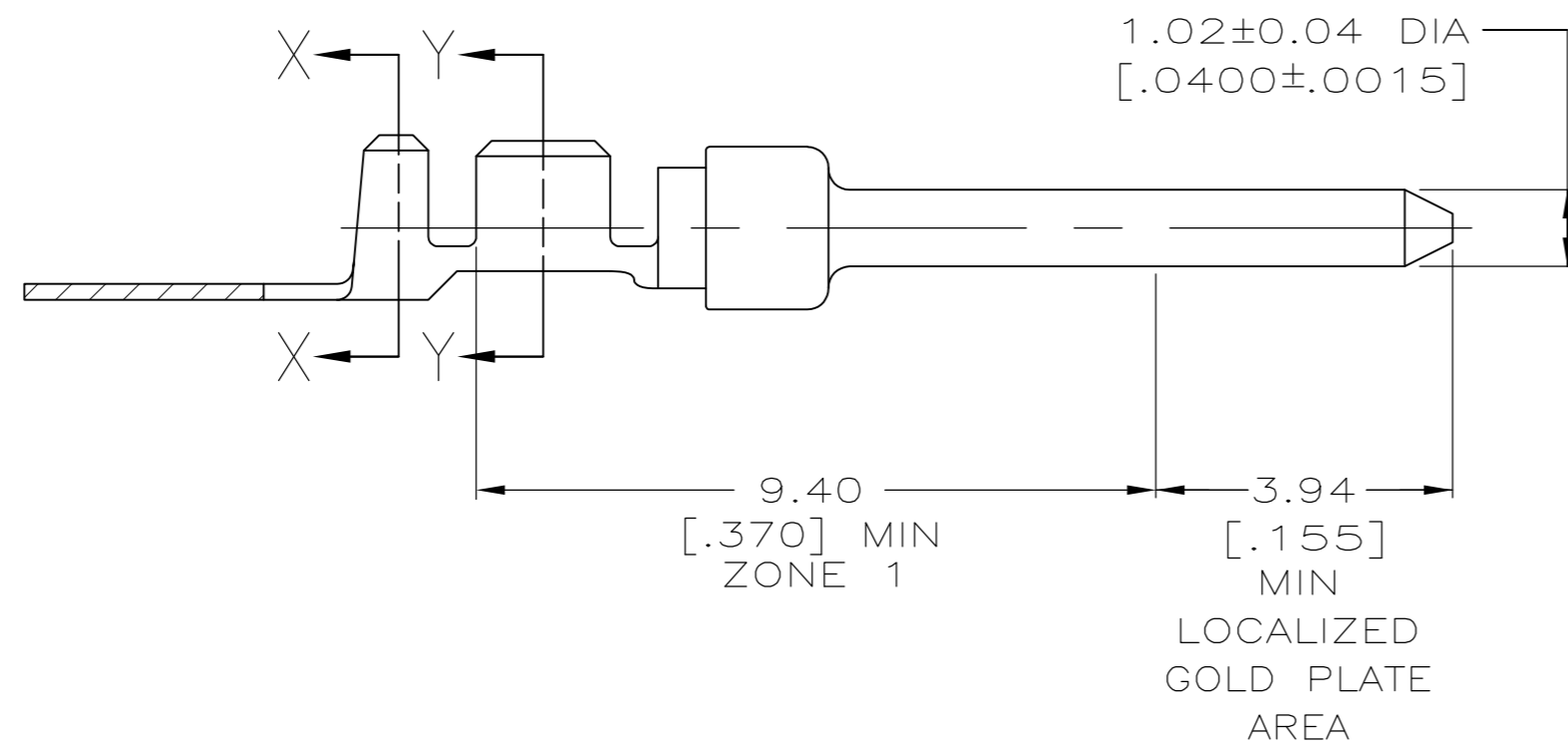
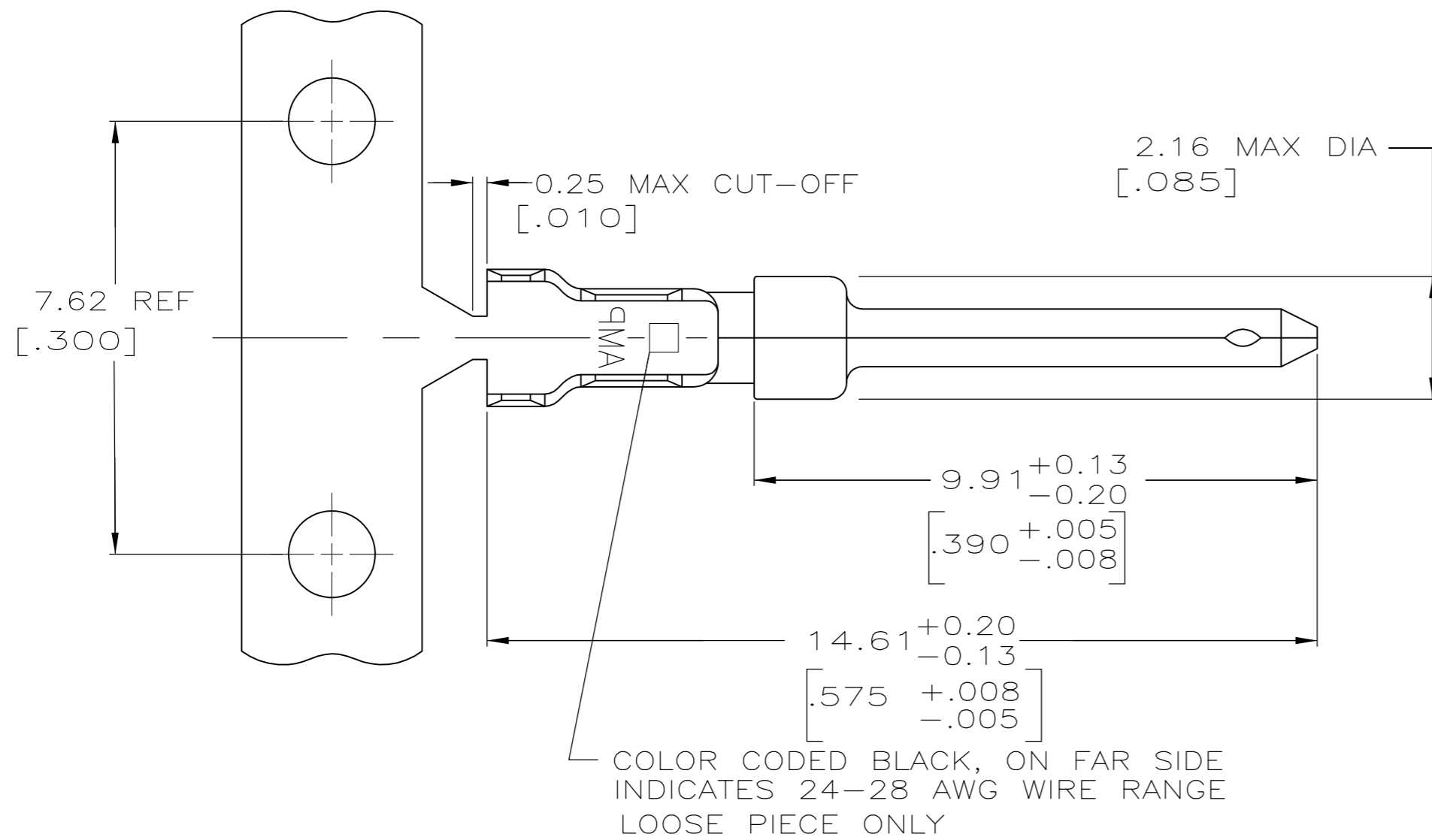

SECTION X-X
INSULATION BARREL
SCALE 20:1

SECTION Y-Y
WIRE BARREL
SCALE 20:1

- 1 FOR MINI-APPLICATOR.
- 2 FOR HAND TOOL USE ONLY.
- 3. WIRE RANGE OF 24-28 AWG, INSULATION RANGE OF 1.27-1.52 [.050-.060].
- 4. GOLD PLATING MAY NOT APPEAR ON CARRIER STRIP.
- 4 GOLD PLATING PER MIL-G-45204. NICKEL PLATING PER QQ-N-290. TIN PLATING PER MIL-T-10727. NICKEL UNDERPLATE COVERS ENTIRE CONTACT.
- 5 GOLD PLATED IN LOCALIZED GOLD PLATE AREA AS FOLLOWS:
- 6 0.76µm [.000030] MIN GOLD IN MATED AREA, GOLD FLASH ON REMAINDER OF LOCALIZED GOLD PLATE AREA AND ZONE 1 OF CONTACT, ALL OVER 1.27µm [.000050] MIN NICKEL UNDERPLATE.
OR
GOLD FLASH OVER PALLADIUM-NICKEL PLATE, 0.76µm [.000030] MIN TOTAL IN MATED AREA, GOLD FLASH ON REMAINDER OF LOCALIZED GOLD PLATE AREA AND ZONE 1 OF CONTACT, ALL OVER 1.27µm [.000050] MIN NICKEL UNDERPLATE.
- 7 GOLD PLATED IN LOCALIZED GOLD PLATED AREA, GOLD FLASH IN MATED AREA, TIN PLATED WIRE BARRELS, OVER 0.76µm [.000030] NICKEL.
- 8 GOLD PLATED IN LOCALIZED GOLD PLATED AREA, 0.76µm [.000030] GOLD IN MATED AREA, TIN PLATED WIRE BARRELS OVER 1.27µm [.000050] NICKEL.
- 9 OBSOLETE.
- 10 PACKAGED ON CARDBOARD REELS.
- 11 PACKAGED ON PLASTIC CORRUGATED REELS

11	6	-	1-66682-3
-	8	91-66682-1	9 66682-9
-	7	-	9 66682-6
10	6	66682-4	66682-2
PACKAGING	FINISH	LOOSE PIECE	PART NUMBER
	5		1

THIS DRAWING IS A CONTROLLED DOCUMENT. DIMENSIONING AND TOLERANCING PER ASME Y14.5M-2009		DWN S. WELDON 9-9-86	TE Connectivity	
DIMENSIONS: mm [INCHES]		CHK C. RICHARD 9-9-86		
TOLERANCES UNLESS OTHERWISE SPECIFIED:		APVD V. KUMAR 9-10-86	NAME	
0 PLC ± -	1 PLC ± -	PRODUCT SPEC	PIN CONTACT, SIZE 20 DF, 24-28 AWG, AMPLIMITE	
2 PLC ± 0.13 [.005]	3 PLC ± -	APPLICATION SPEC	SIZE	CAGE CODE
4 PLC ± -	ANGLES ± -	114-10000	A2	00779
MATERIAL BRASS PER MIL-C-50	FINISH SEE TABLE	WEIGHT 0.000000	DRAWING NO	RESTRICTED TO
		CUSTOMER DRAWING	C=66682	-
		SCALE 10:1	SHEET 1 OF 1	REV M

单击下面可查看定价，库存，交付和生命周期等信息

[>>TE Connectivity\(泰科\)](#)