

LOC	DIST	REV	DATE	BY	CHK
-	-	5	15JAN2014	BL	JY
-	-	6	27MAY2014	BL	JY
-	-	7	27JAN2015	RG	MC
-	-	A	7MAR2016	RG	SH

- ① CAGE ASSEMBLY MATERIAL: NICKEL SILVER, 0.25 THICK
 HEAT SINK MATERIAL: ALUMINUM
 HEAT SINK CLIP MATERIAL: STAINLESS STEEL
 EMI SPRING MATERIAL: COPPER ALLOY
 EMI GASKET PLATE MATERIAL: STAINLESS STEEL
 LIGHT PIPE MATERIAL: CLEAR POLYCARBONATE
- ② PITCH BETWEEN PORTS OF ONE 1X3 CAGE ASSEMBLY.
- ③ SPACING BETWEEN CAGES ON THE SAME PC BOARD, TO BE SPECIFIED BY CUSTOMER, MUST COMPLY WITH MINIMUM DIMENSIONS SHOWN.
- ④ REFERENCE APPLICATION SPEC 114-13217 FOR RECOMMENDED DRILL HOLE DIAMETER AND PLATING THICKNESS.
- ⑤ DATUMS AND BASIC DIMENSIONS ESTABLISHED BY CUSTOMER.
- ⑥ DIMENSION F IS THE NOMINAL THICKNESS OF CUSTOMER SUPPLIED PC BOARD,
 SINGLE SIDED PC BOARD MINIMUM THICKNESS = 1.45mm
 DOUBLE SIDED PC BOARD MINIMUM THICKNESS = 5.0mm PER CUSTOMER.
- ⑦ HEAT SINKS, LIGHT PIPES, AND HEAT SINK CLIPS SHIPPED ASSEMBLED TO CAGE ASSEMBLY. CAGE ASSEMBLY MAY BE PRESSED INTO THE PCB AS SHIPPED.
- ⑧ DATUM A IS TOP SURFACE OF PC BOARD.
- ⑨ DIMENSION APPLIES WITH MODULE INSERTED IN CAGE.
- ⑩ UNPLATED THRU HOLE.
- 11. MATES WITH QSFP MSA COMPATIBLE TRANSCEIVER.
- ⑫ SURFACE TRACES PERMITTED WITHIN THIS AREA EXCEPT WHERE CAGE STANDOFFS, SHOWN IN DETAIL S, CONTACT PC BOARD.
- ⑬ BASELINE FOR THESE DIMENSIONS IS THE CENTER OF COMPLIANT PIN HOLE.
- ⑭ DATE CODE (YYWWD) MARKED ON TOP OF CAGE AND CONCEALED BY HEAT SINKS APPLIES TO CAGE ASSEMBLY ONLY.

- ⑮ REFERENCE APP SPEC 114-13217 FOR GASKET THICKNESS CALCULATION.
- ⑯ EMI SPRING FINISH: 2um MINIMUM TIN
 HEAT SINK FINISH: BLACK ANODIZED.
- ⑰ HEAT SINKS AND CLIPS SHIPPED ASSEMBLED TO CAGE ASSEMBLY. CAGE ASSEMBLY MAY BE PRESSED INTO THE PCB AS SHIPPED. LIGHT PIPES, SHIPPED UNATTACHED, MUST BE ASSEMBLED BY CUSTOMER AFTER THE CAGE IS SEATED IN THE PCB.

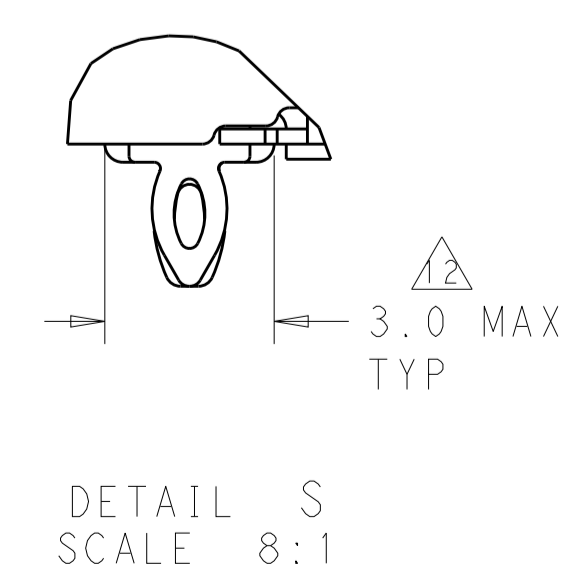
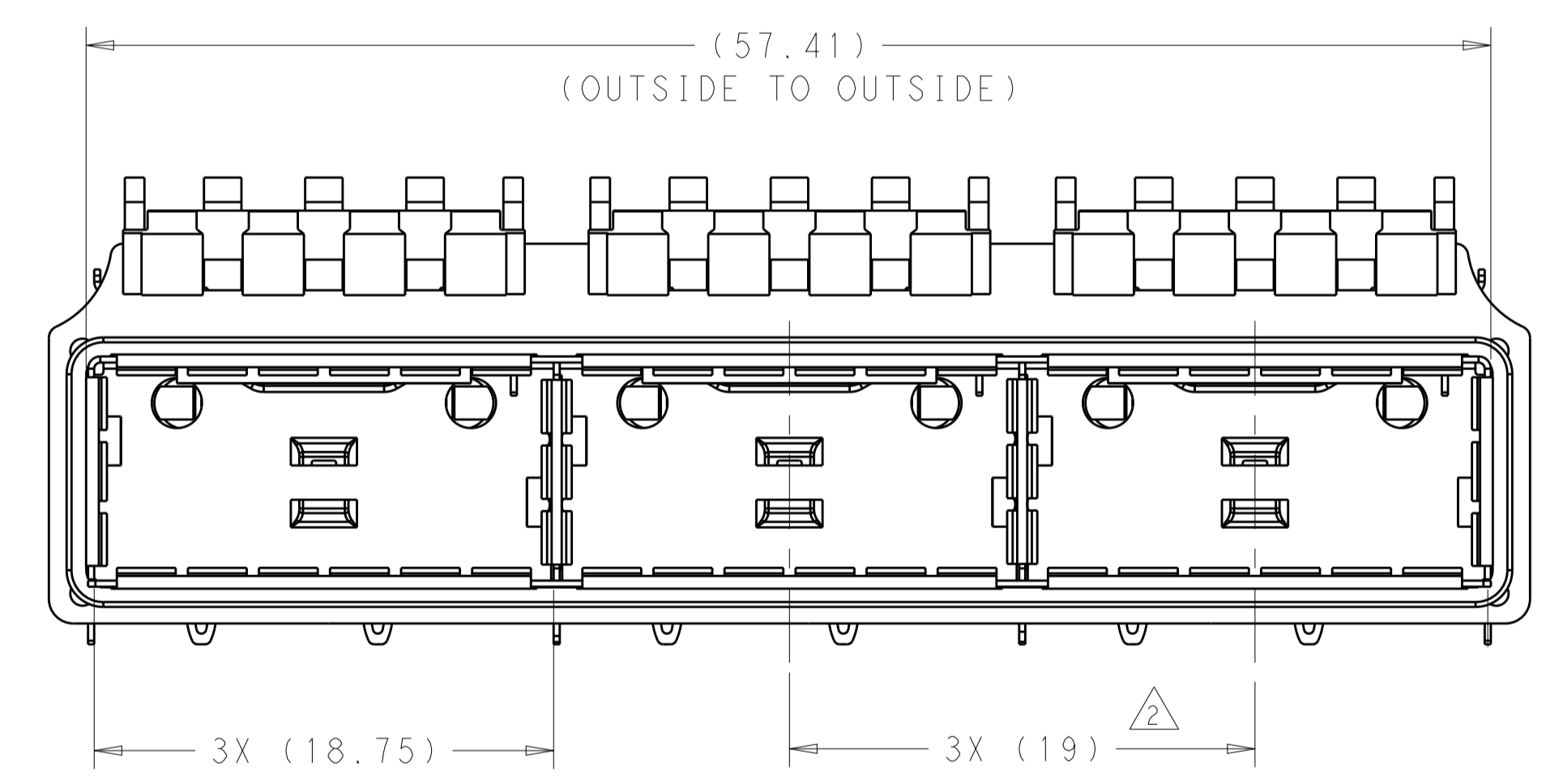
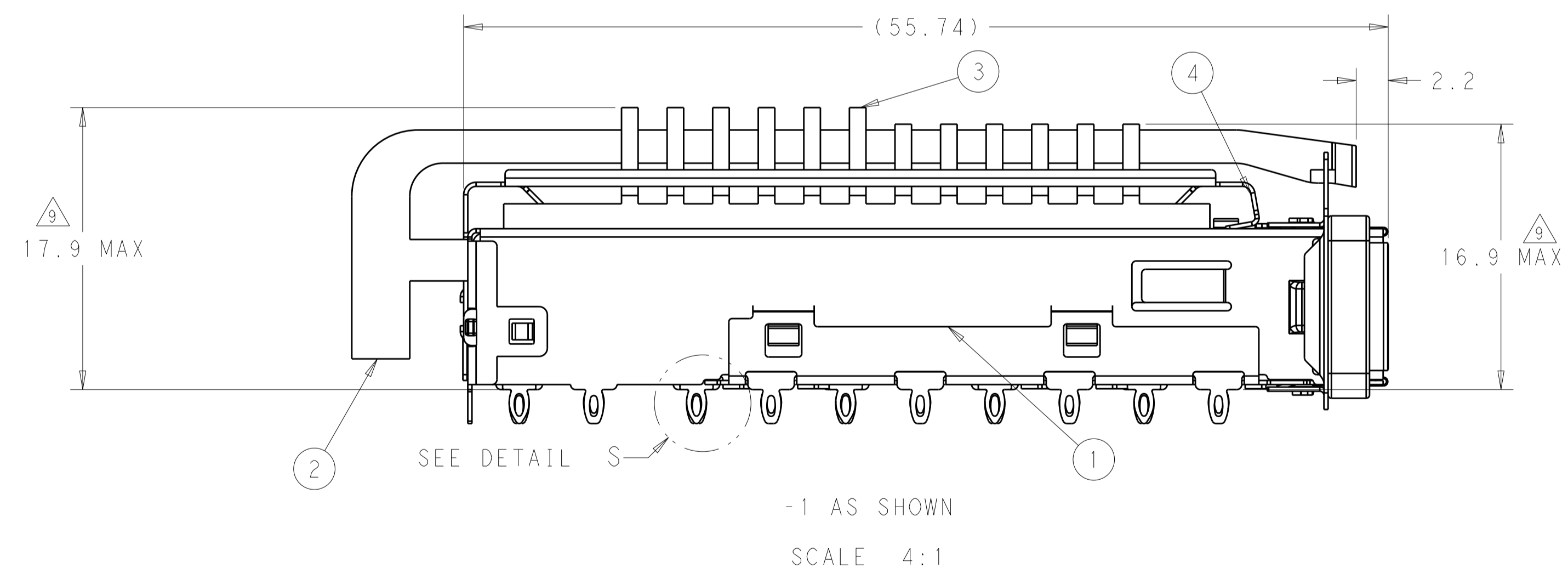

SOLID, SQUARE GASKET	WITHOUT LP	WITH HS	2170507-4
HOLLOW, ROUND GASKET	WITH LP	WITH HS	2170507-3
HOLLOW, ROUND GASKET	WITHOUT LP	WITHOUT HS	2170507-2
SOLID, SQUARE GASKET	WITH LP	WITH HS	2170507-1
GASKET	LIGHT PIPE	HEAT SINK	PART NUMBER

THIS DRAWING IS A CONTROLLED DOCUMENT.		OWN: TIM XUE 27MAR2013	TE Connectivity
DIMENSIONS: mm		CHK: ALEX CAI 27MAR2013	
TOLERANCES UNLESS OTHERWISE SPECIFIED:		APVD: ALEX CAI 27MAR2013	
0 PLC ± 1 PLC ±0.35 2 PLC ±0.25 3 PLC ± 4 PLC ± ANGLES ±		NAME: 1X3 CAGE ASSEMBLY, THRU BEZEL W/ELASTOMERIC GASKET AND HEAT SINKS QSFP PRODUCT SPEC: 108-2286 APPLICATION SPEC: 114-13217 WEIGHT: - CUSTOMER DRAWING	
MATERIAL: ①		FINISH: ⑮	SIZE: CAGE CODE DRAWING NO: A100779C=2170507 RESTRICTED TO: - SCALE: 1:1 SHEET 1 OF 6 REV A

LOC	DIST	REV	DATE	BY	APPV
		1			

REV	DESCRIPTION	DATE	BY	APPV
-	SEE SHEET 1	-	-	-

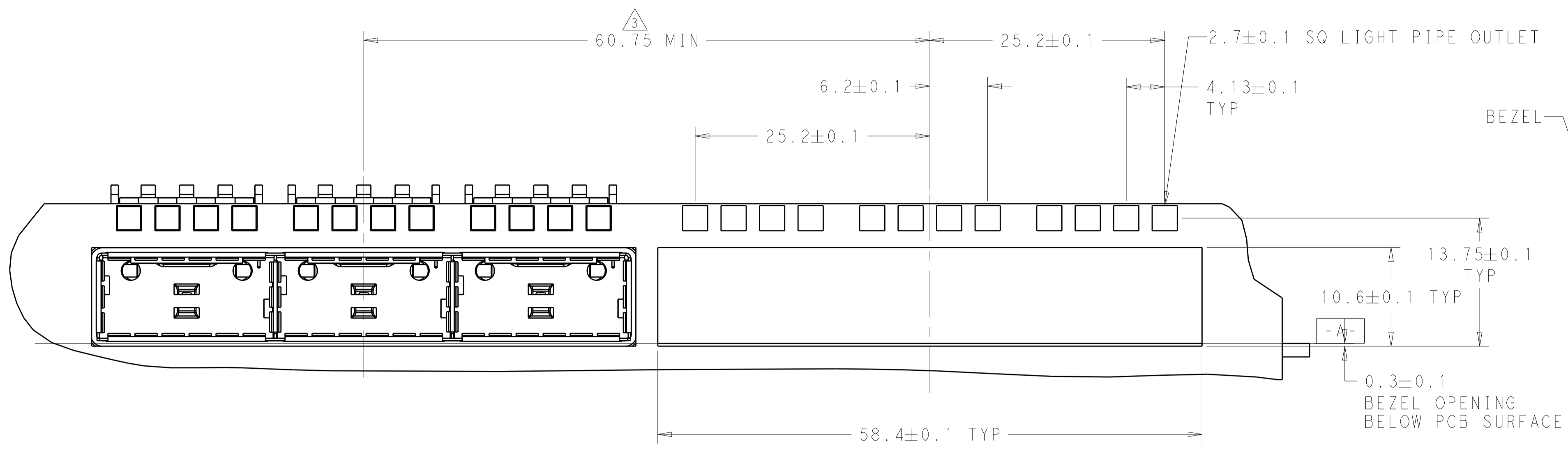

ONE SIDED CONFIGURATION
 SCALE 3:1

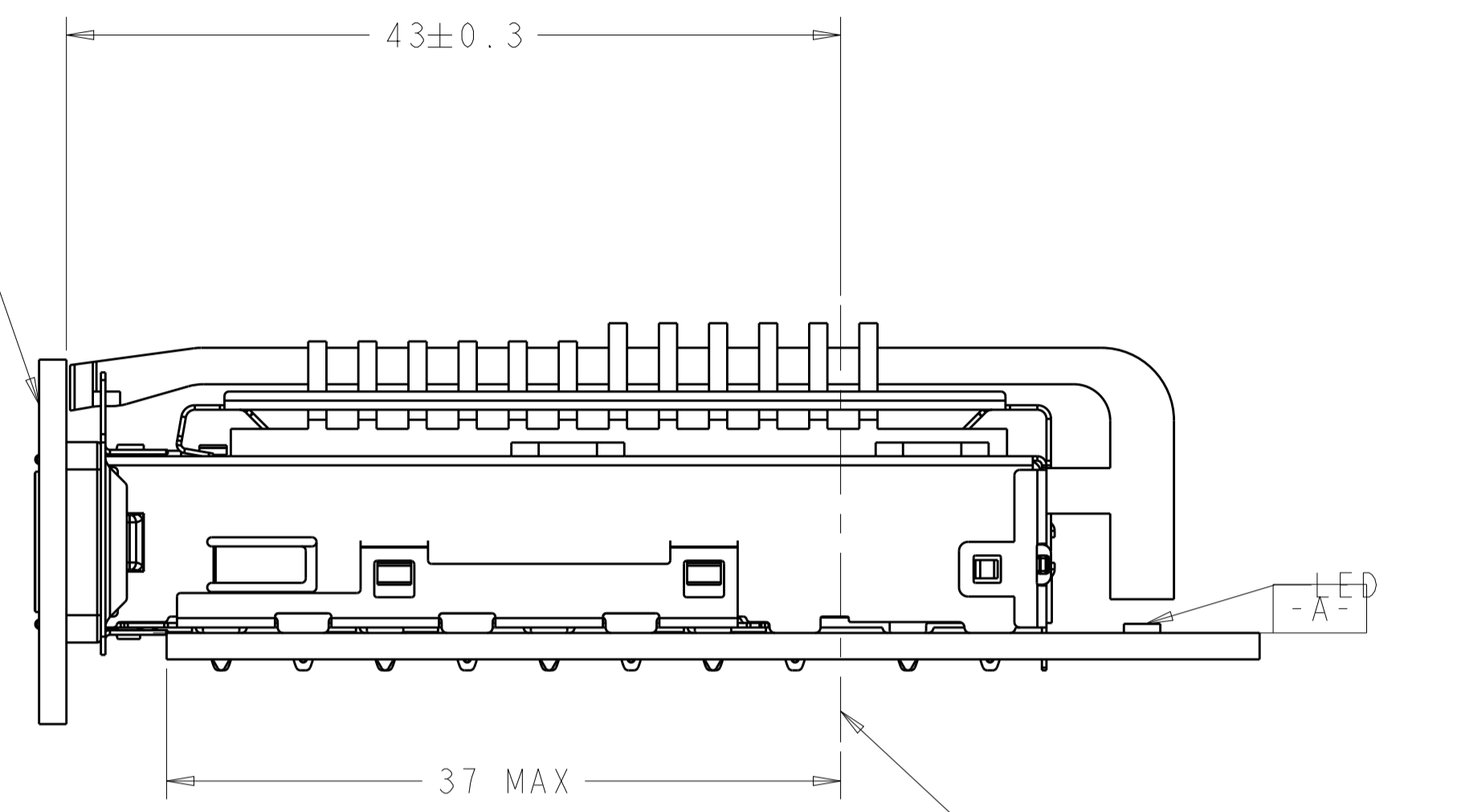

SCALE 3:1

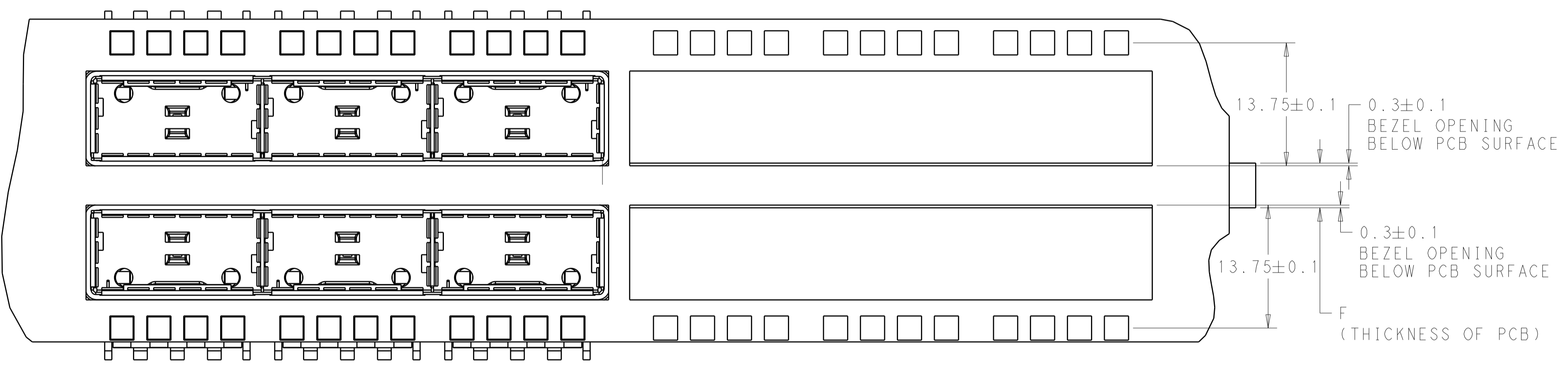

BELLY TO BELLY CONFIGURATION
 SIMILAR TO ONE SIDED
 EXCEPT WHERE NOTED
 SCALE 3:1

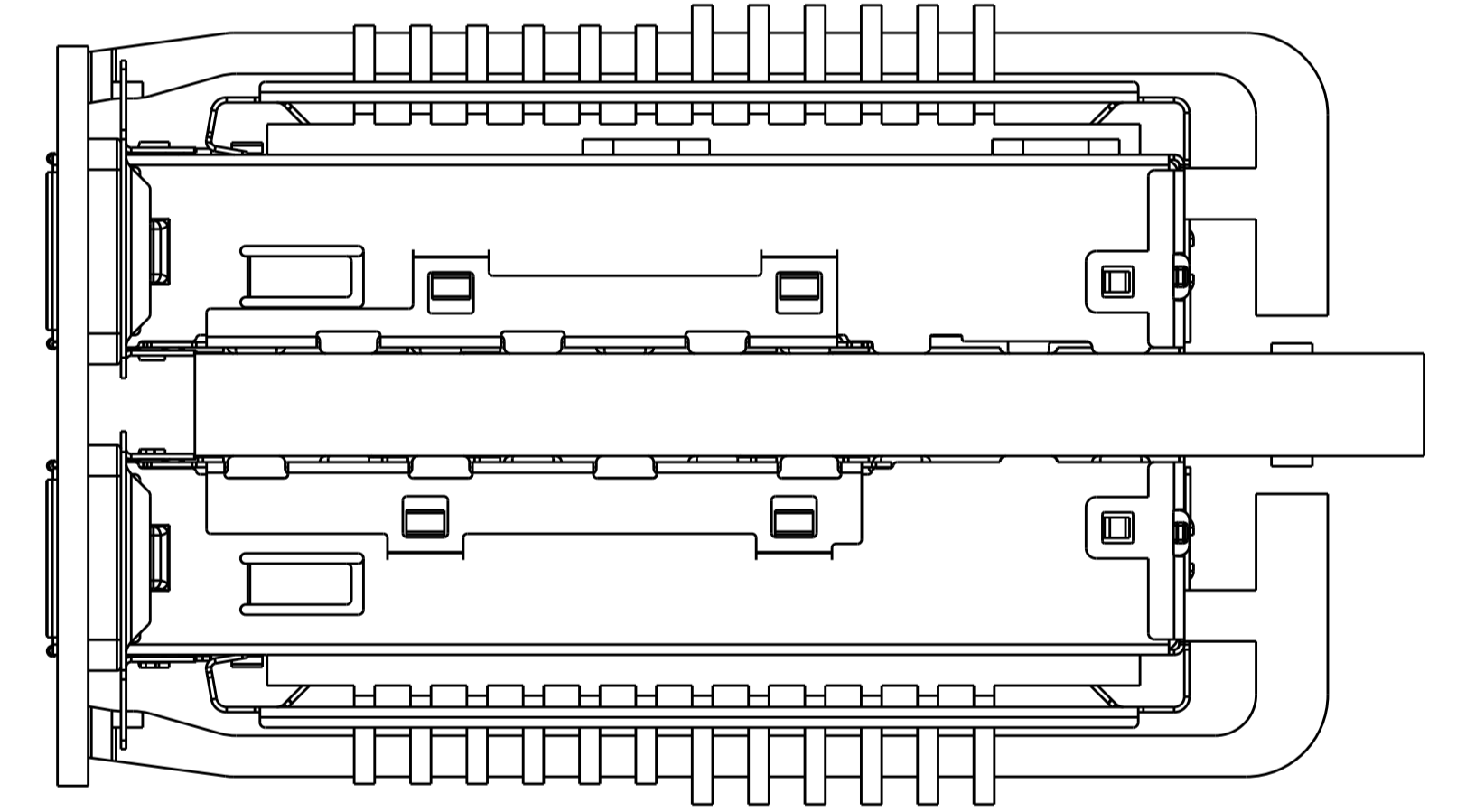

SCALE 3:1

THIS DRAWING IS A CONTROLLED DOCUMENT.		OWN: TIM XUE 27MAR2013	TE Connectivity NAME: 1X3 CAGE ASSEMBLY, THRU BEZEL W/ELASTOMERIC GASKET AND HEAT SINKS QSPF PRODUCT SPEC: 108-2286 APPLICATION SPEC: 114-13217 SIZE: A1 CAGE CODE: 00779 DRAWING NO: C=2170507 RESTRICTED TO: -
DIMENSIONS: mm		CHK: ALEX CAI 27MAR2013	
TOLERANCES UNLESS OTHERWISE SPECIFIED:		APPV: ALEX CAI 27MAR2013	
0 PLC ± 1 PLC ±0.35 2 PLC ±0.25 3 PLC ± 4 PLC ± ANGLES ±		MATERIAL: FINISH: WEIGHT: CUSTOMER DRAWING	
SCALE 1:1		SHEET 2 OF 6	REV A

LOC	DIST	REV	DATE	APPD
		1		

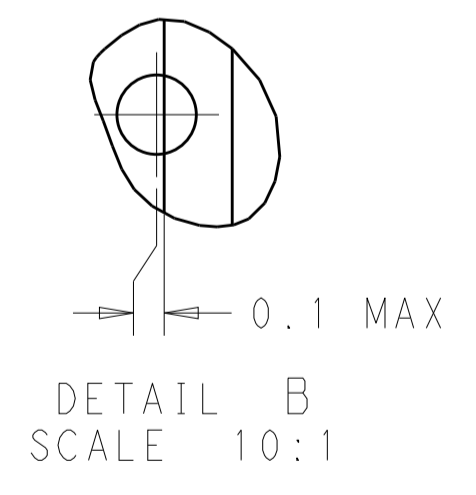
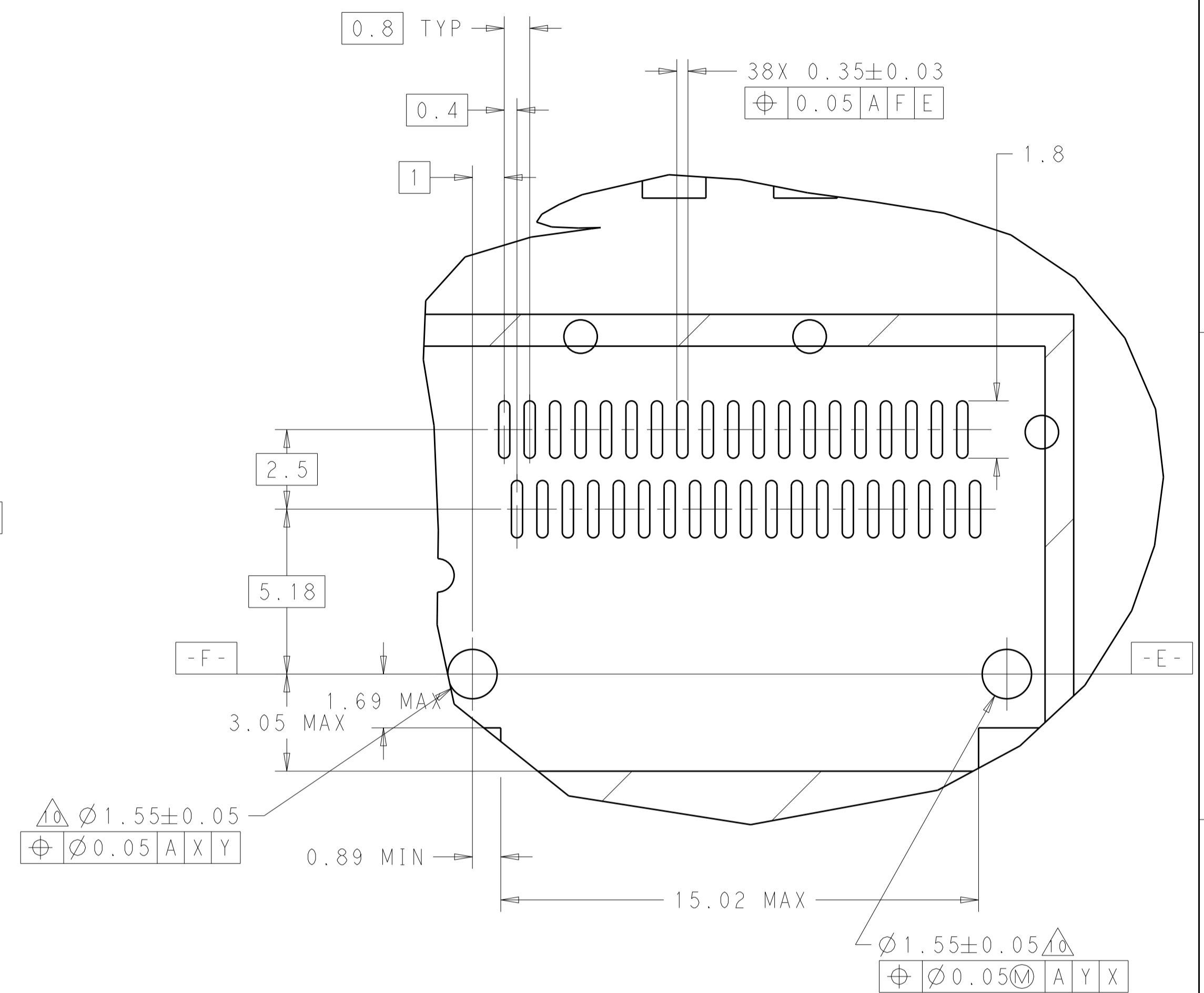
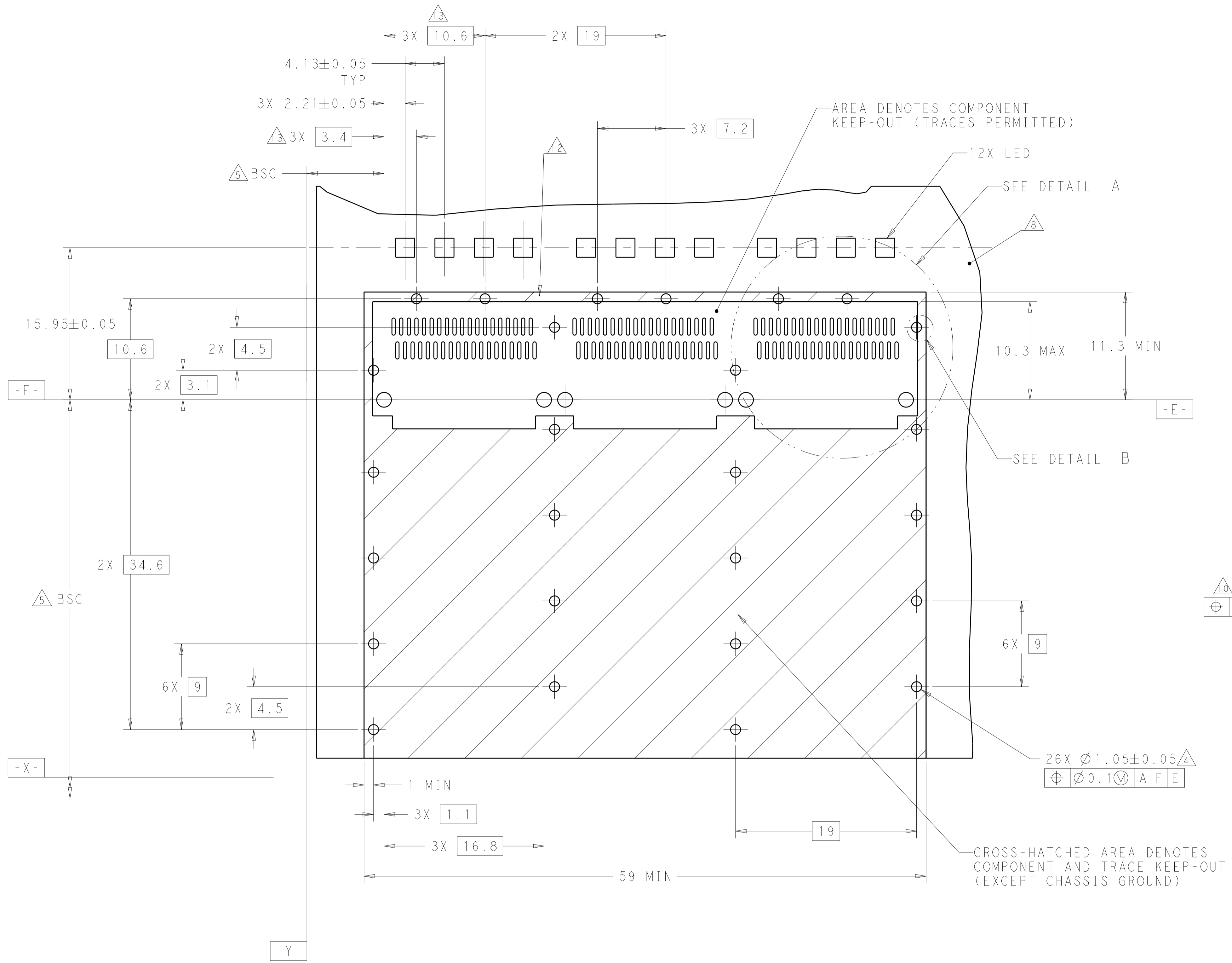

THIS DRAWING IS A CONTROLLED DOCUMENT.		OWN: TIM XUE 27MAR2013	TE Connectivity
DIMENSIONS: mm		CHK: ALEX CAI 27MAR2013	
TOLERANCES UNLESS OTHERWISE SPECIFIED:		APPD: ALEX CAI 27MAR2013	NAME: 1X3 CAGE ASSEMBLY, THRU BEZEL W/ELASTOMERIC GASKET AND HEAT SINKS QSPF
0 PLC ±	1 PLC ±0.35	PRODUCT SPEC: 108-2286	SIZE: A100779C=2170507
2 PLC ±0.25	3 PLC ±	APPLICATION SPEC: 114-13217	RESTRICTED TO: -
4 PLC ±	ANGLES ±	WEIGHT: -	SCALE: 1:1 SHEET 3 OF 6 REV A
MATERIAL:	FINISH:	CUSTOMER DRAWING	

LOC	DIST	REVISIONS			
P	LTH	DESCRIPTION	DATE	DWN	APVD
-	-	SEE SHEET 1	-	-	-

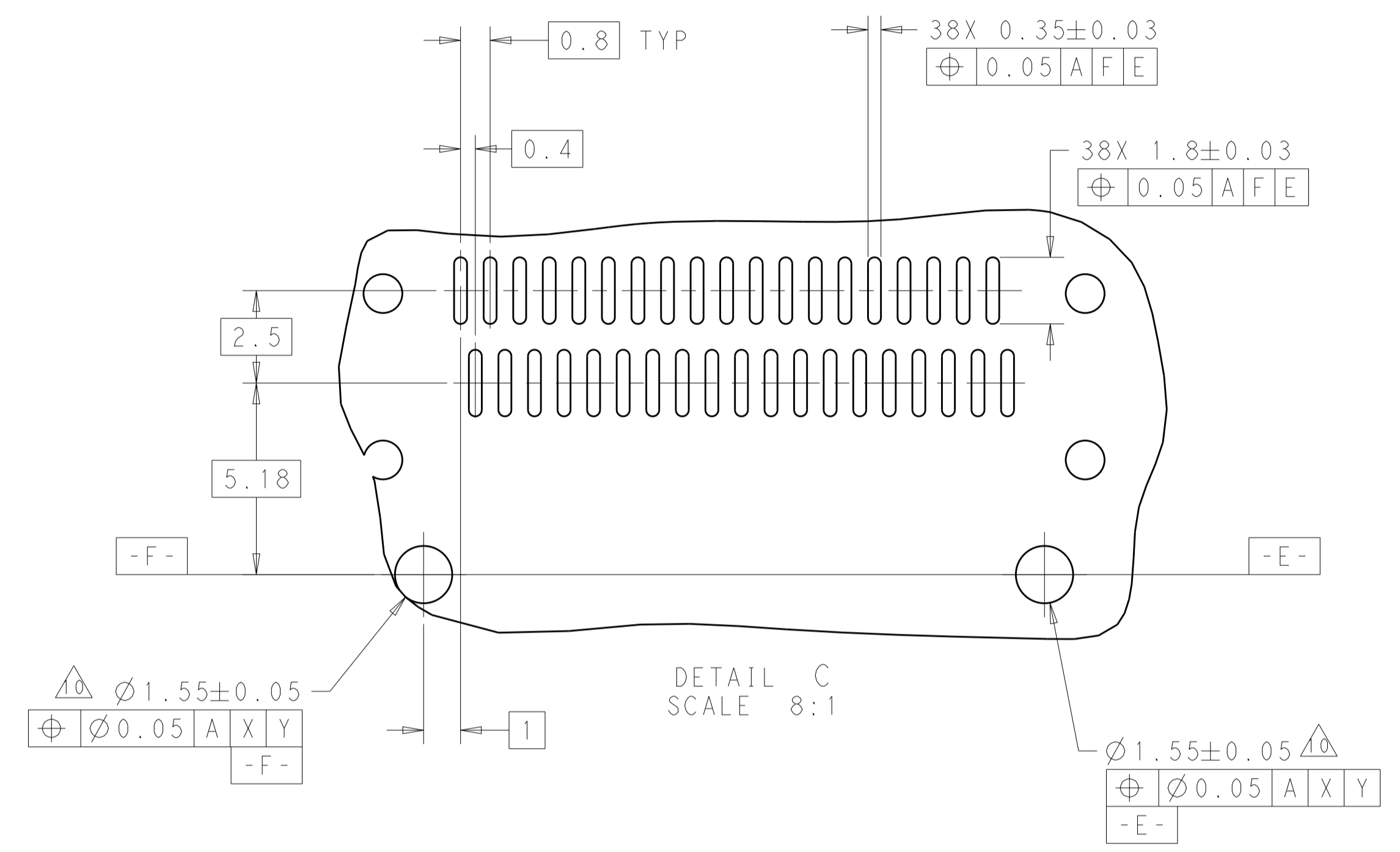
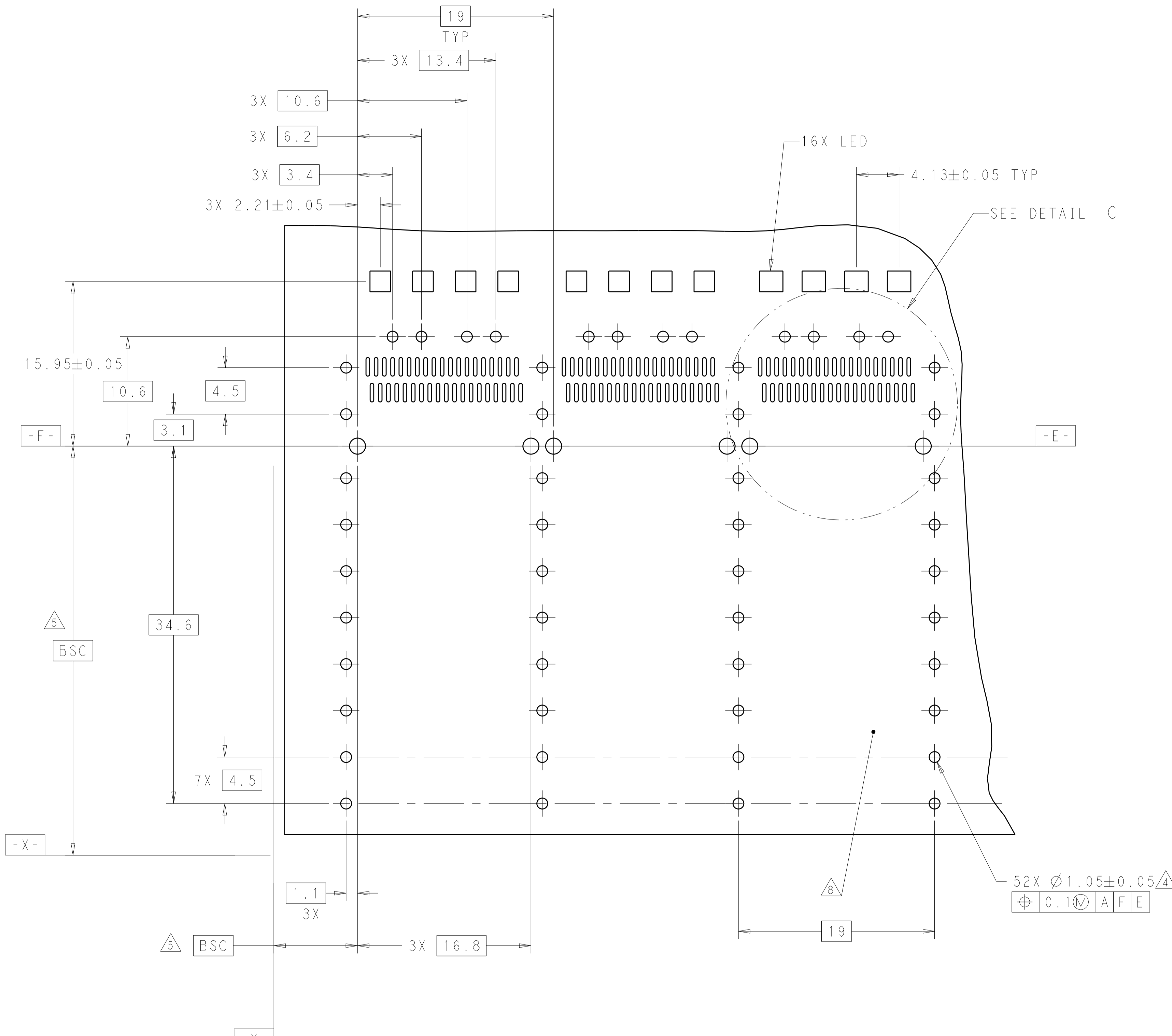

RECOMMENDED PC BOARD LAYOUT
 BELLY TO BELLY CONFIGURATION
 SEE SHEET 3 FOR COMPONENT AND TRACE KEEP-OUTS
 SCALE 4:1

THIS DRAWING IS A CONTROLLED DOCUMENT.		DWN TIM XUE 27MAR2013	TE Connectivity
DIMENSIONS:		CHK ALEX CAI 27MAR2013	
mm	TOLERANCES UNLESS OTHERWISE SPECIFIED:	APVD ALEX CAI 27MAR2013	NAME 1X3 CAGE ASSEMBLY, THRU BEZEL W/ELASTOMERIC GASKET AND HEAT SINKS QSFP
0 PLC ± 1 PLC ±0.35 2 PLC ±0.25 3 PLC ± 4 PLC ± ANGLES ±	FINISH	PRODUCT SPEC 108-2286 APPLICATION SPEC 114-13217 WEIGHT	SIZE A100779C=2170507 RESTRICTED TO
MATERIAL	FINISH	CUSTOMER DRAWING SCALE 1:1 SHEET 4 OF 6 REV A	

LOC		DIST		REVISIONS			
P	LTN	DESCRIPTION	DATE	DWN	APVD		
-		SEE SHEET 1					

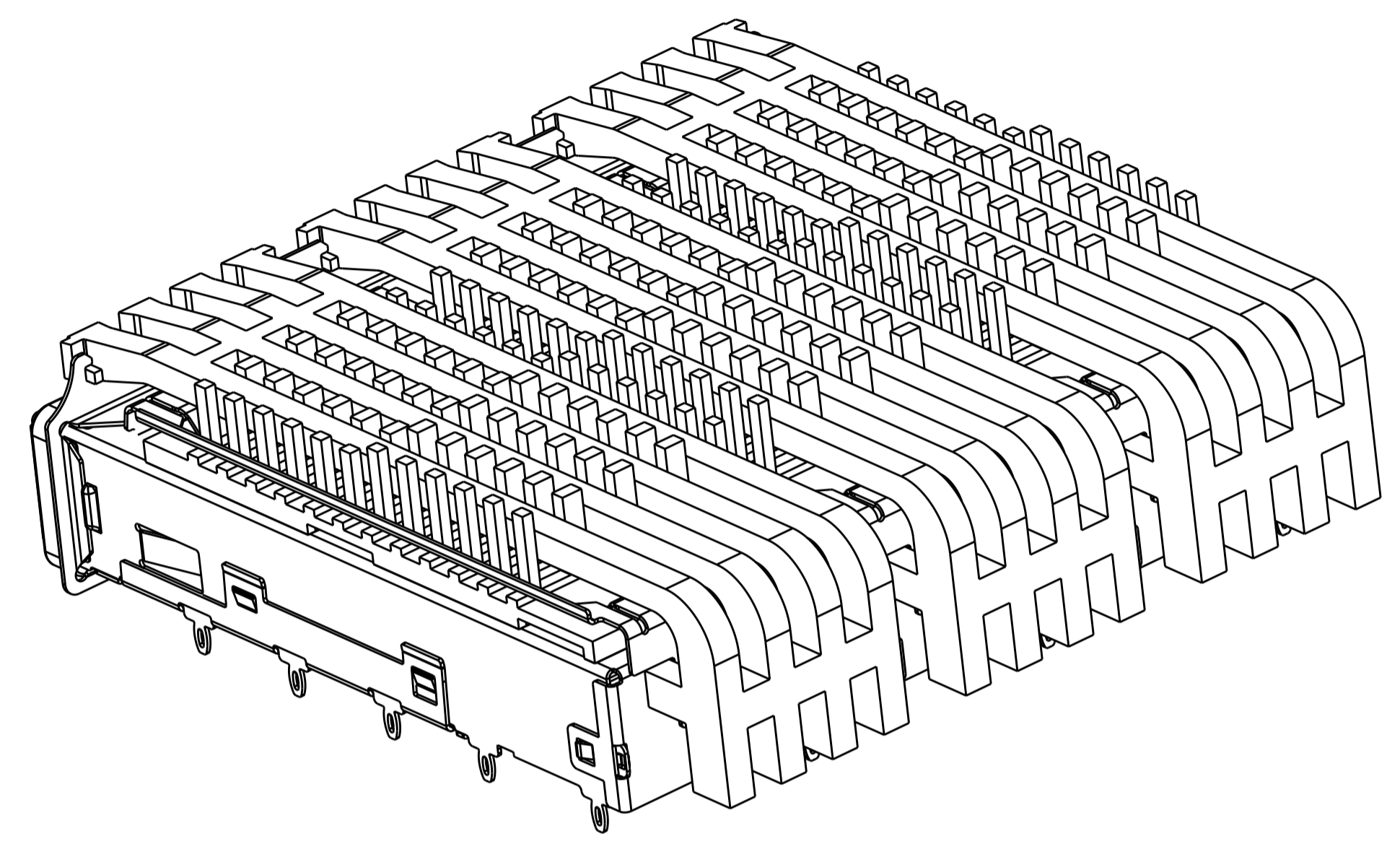

2170507-1 AS SHOWN
SCALE 3:1

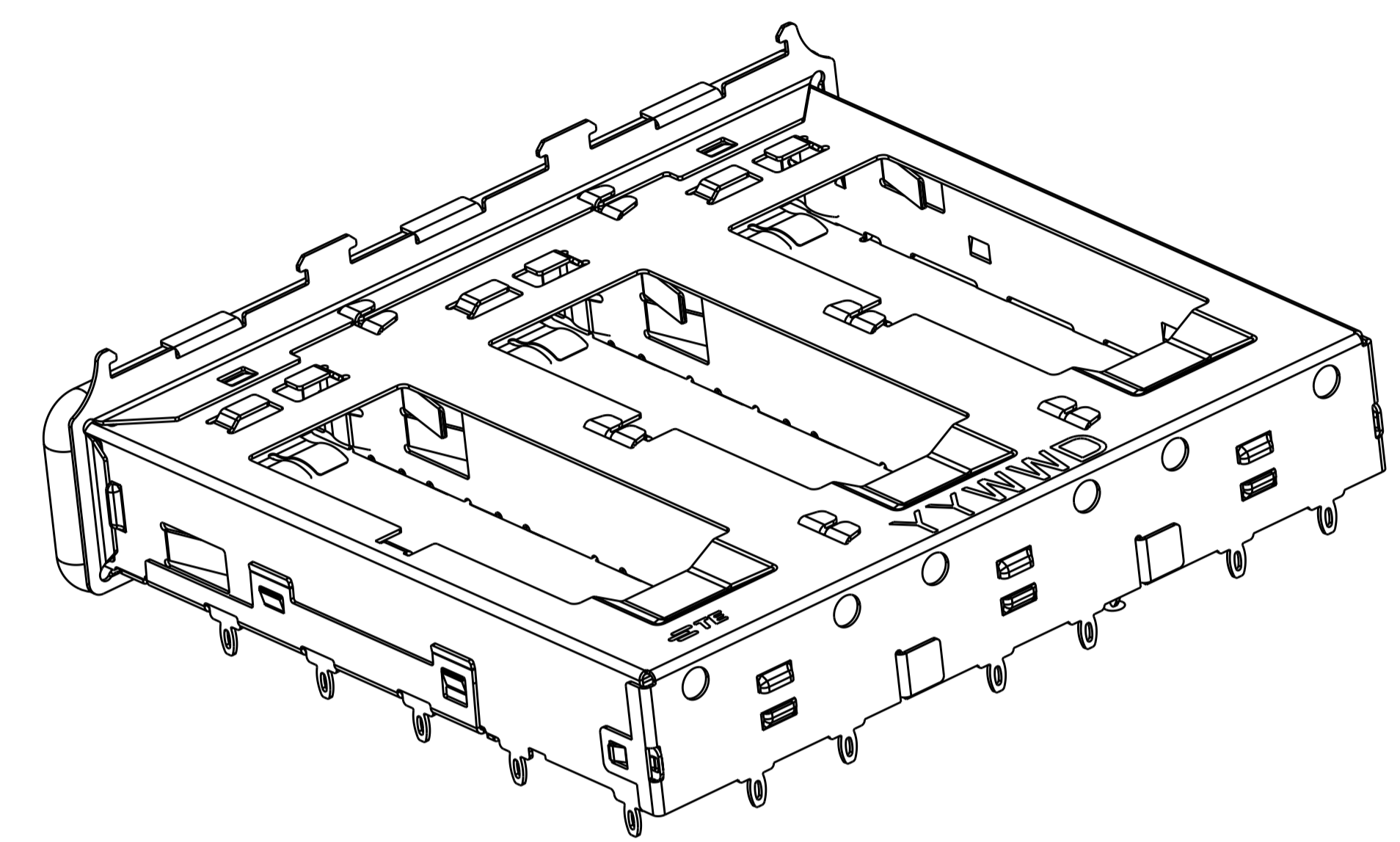

2170507-2 AS SHOWN
SCALE 3:1

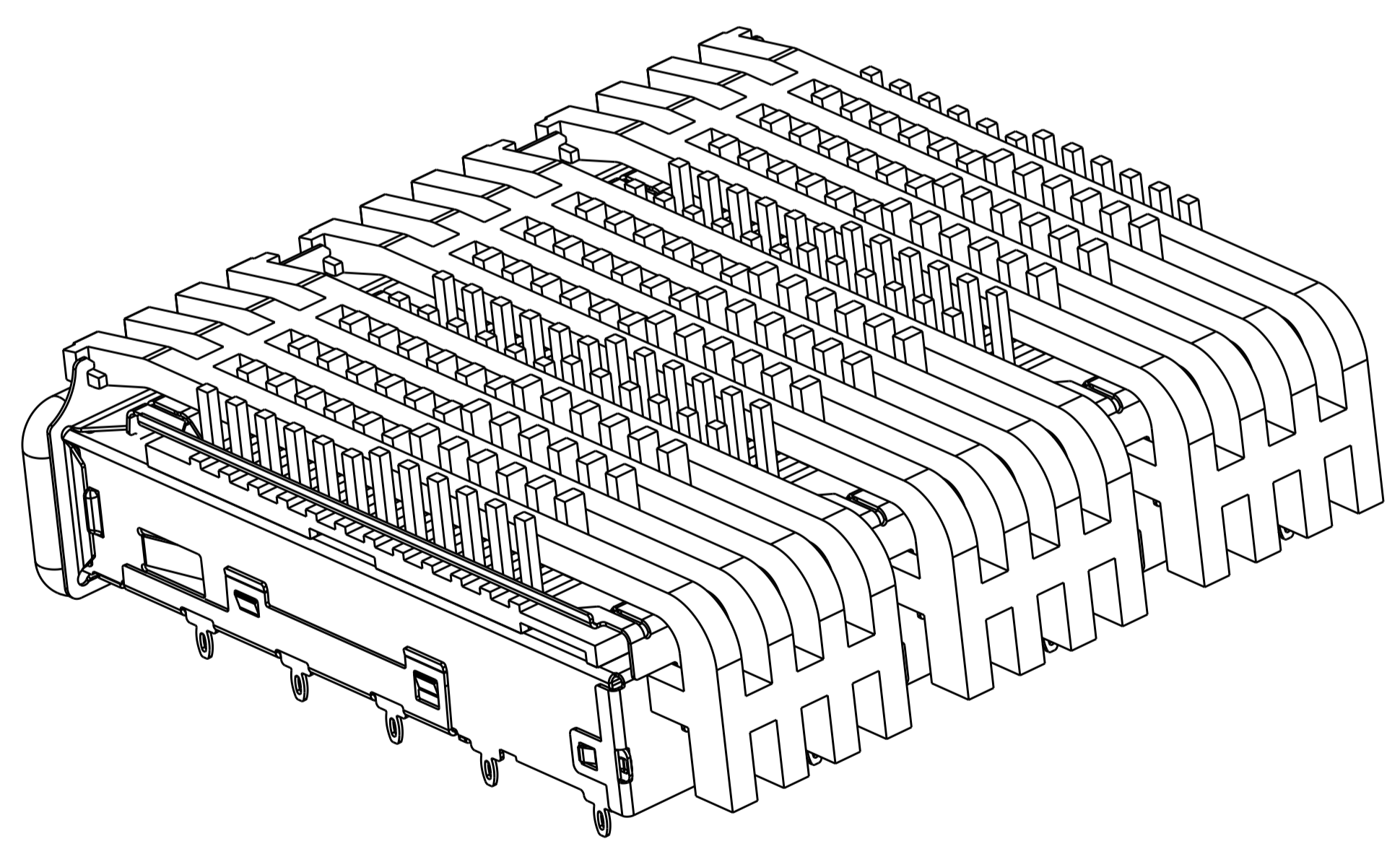

2170507-3 AS SHOWN
SCALE 3:1

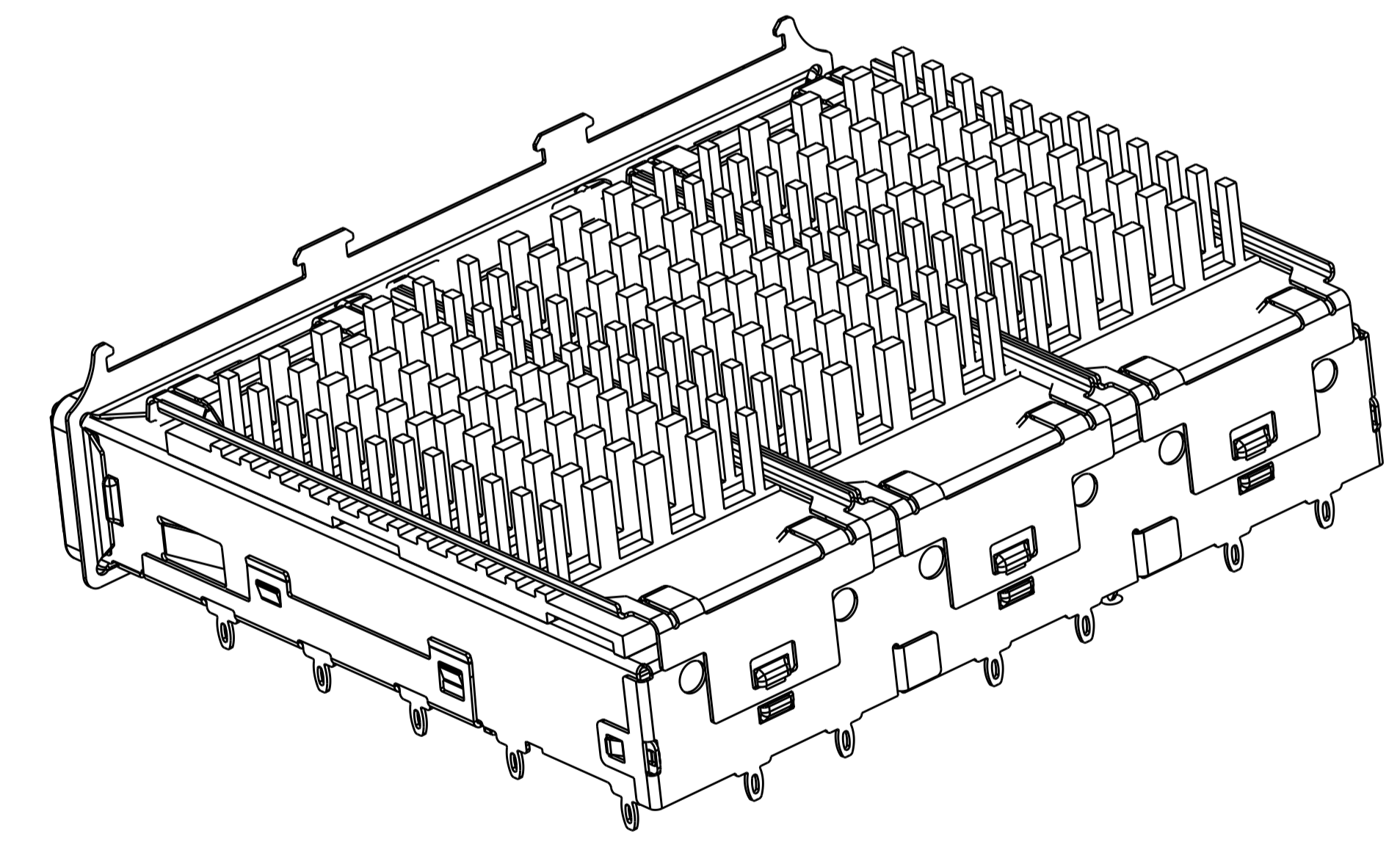

2170507-4 AS SHOWN
SCALE 3:1

THIS DRAWING IS A CONTROLLED DOCUMENT.		DWN	TIM_XUE	27MAR2013	TE Connectivity
DIMENSIONS:		CHK	ALEX_CAI	27MAR2013	
TOLERANCES UNLESS OTHERWISE SPECIFIED:		APVD	ALEX_CAI	27MAR2013	
mm		PRODUCT SPEC	108-2286	NAME	
0 PLC	±	APPLICATION SPEC	114-13217	SIZE	A100779C=2170507
1 PLC	±0.35	WEIGHT		SCALE	1:1
2 PLC	±0.25	CUSTOMER DRAWING		SHEET	5 OF 6
3 PLC	±			REV	A
4 PLC	±				
ANGLES	±				
FINISH					

LOC	DIST	REVISIONS					
		P.	LTN	DESCRIPTION	DATE	DWN	APVD
		-		SEE SHEET 1	-	-	-

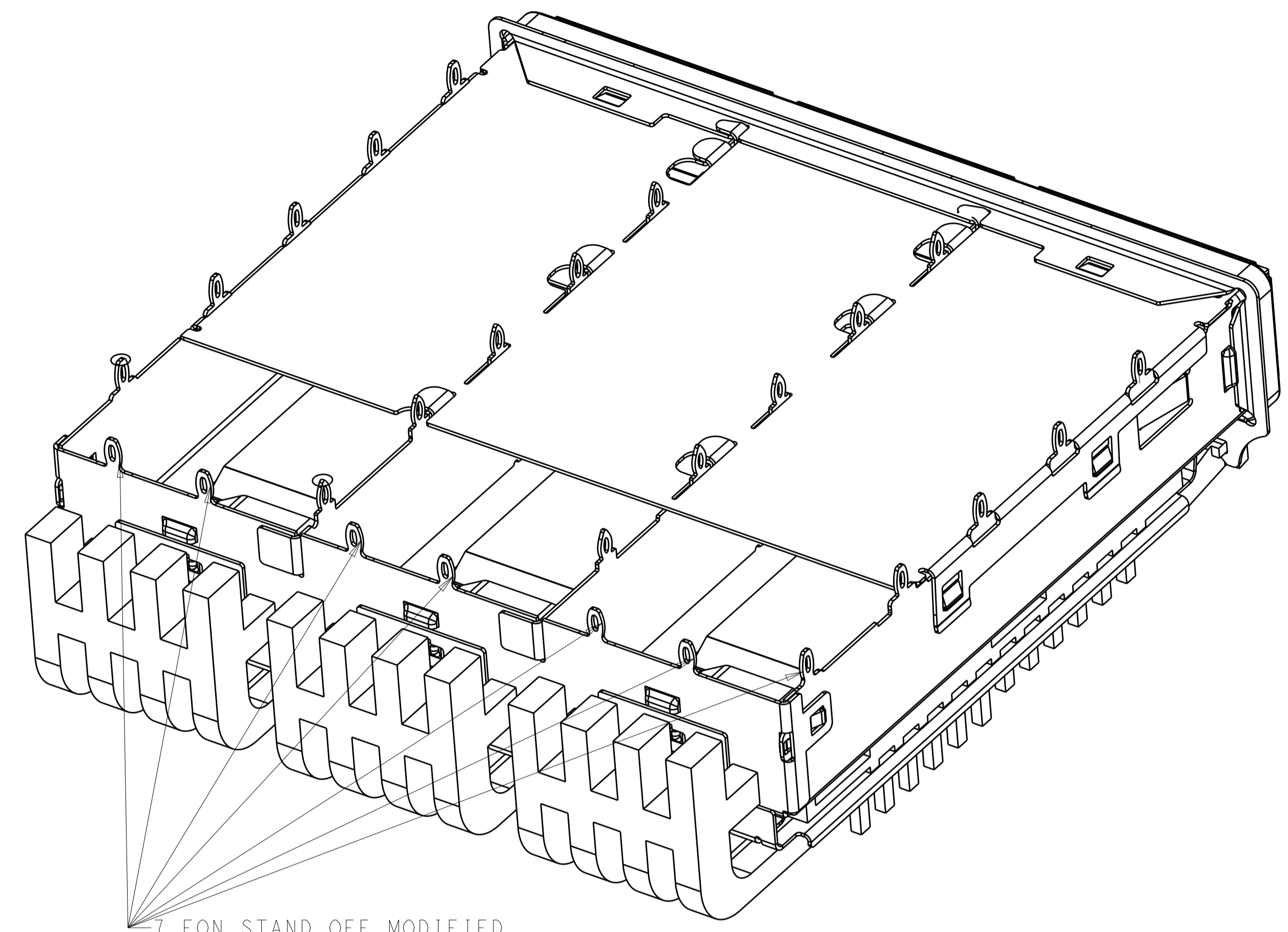

7 EON STAND OFF MODIFIED AS DETAIL D SCALE 4:1

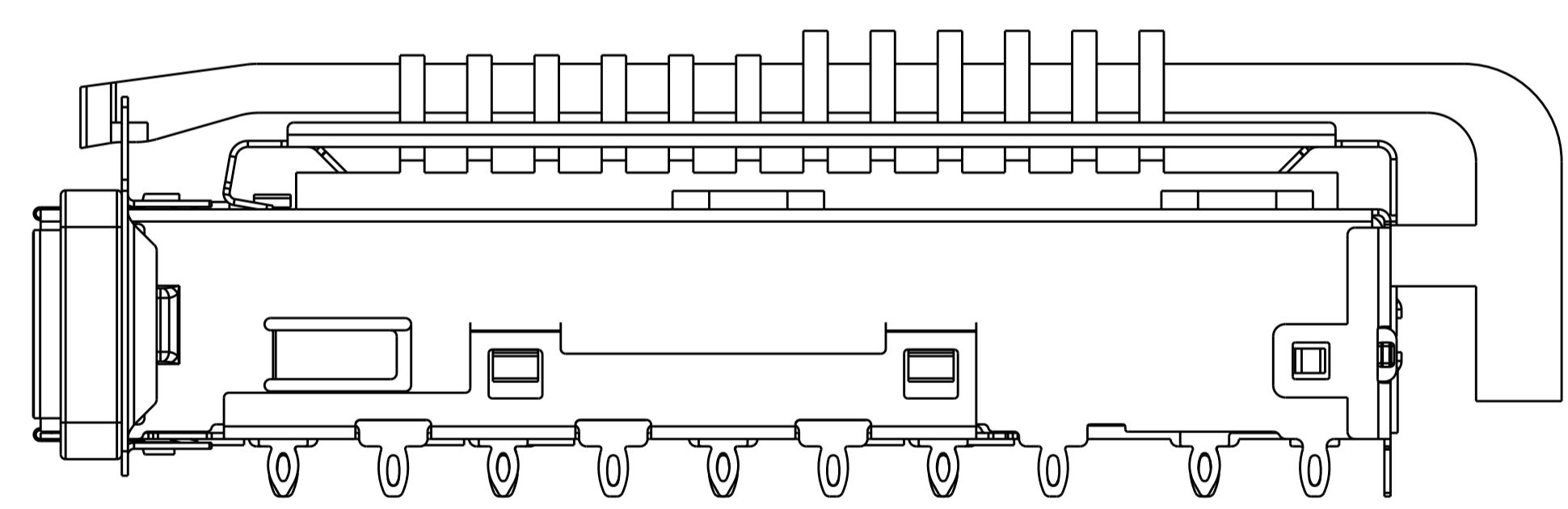

SCALE 4:1

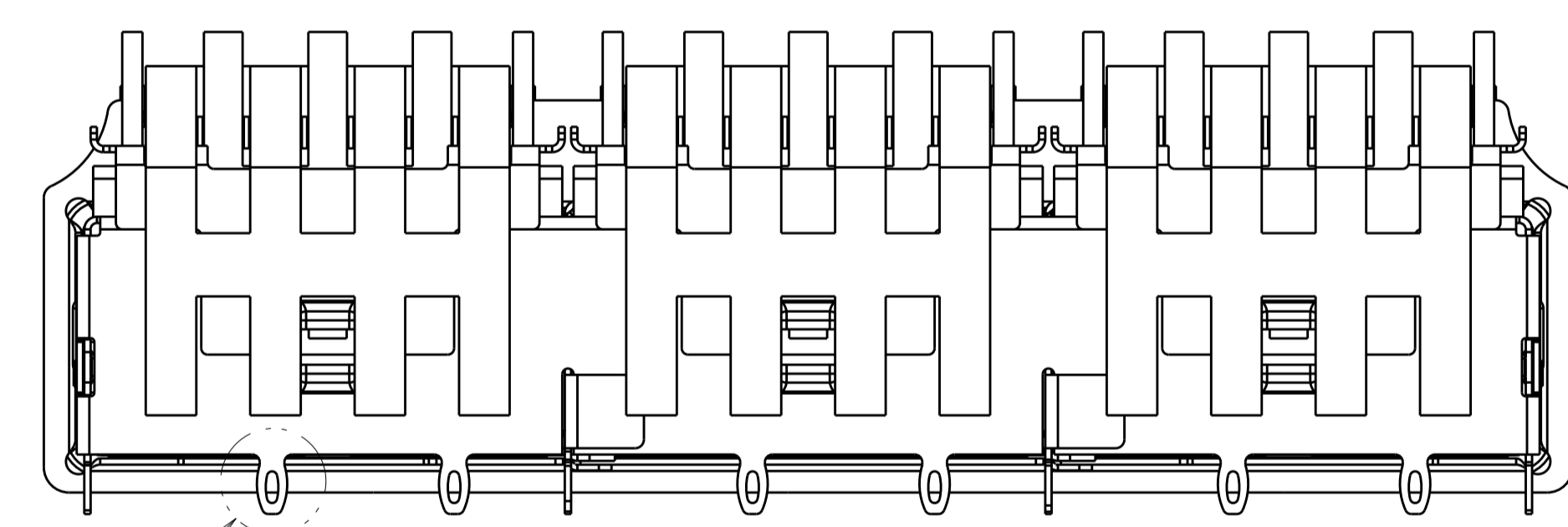

SEE DETAIL D

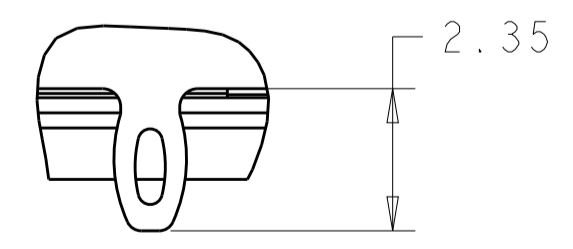

DETAIL D SCALE 8:1

EXCEPT 7 EON STAND OFF MODIFICATION THE OTHER FEATURES ARE SAME WITH 2170507-1

SOLID, SQUARE GASKET	WITH LP	WITH HS	2170507-5
GASKET	LIGHT PIPE	HEAT SINK	PART NUMBER
THIS DRAWING IS A CONTROLLED DOCUMENT.		DWN: TIM XUE 27MAR2013	
DIMENSIONS:		CHK: ALEX CAI 27MAR2013	
TOLERANCES UNLESS OTHERWISE SPECIFIED:		APVD: ALEX CAI 27MAR2013	
mm		NAME: 1X3 CAGE ASSEMBLY, THRU BEZEL W/ELASTOMERIC GASKET AND HEAT SINKS QSPF	
0 PLC	±	PRODUCT SPEC	SIZE: CAGE CODE DRAWING NO
1 PLC	±0.35	108-2286	RESTRICTED TO
2 PLC	±0.25	APPLICATION SPEC	A100779C=2170507
3 PLC	±	114-13217	SCALE 1:1 SHEET 6 OF 6 REV A
4 PLC	±	WEIGHT	
ANGLES	±	CUSTOMER DRAWING	
FINISH			

单击下面可查看定价，库存，交付和生命周期等信息

[>>TE Connectivity\(泰科\)](#)