

THIS DRAWING IS UNPUBLISHED. RELEASED FOR PUBLICATION
 © COPYRIGHT - By - ALL RIGHTS RESERVED.

LOC		DIST		REVISIONS			
P	LTR	DESCRIPTION	DATE	DWN	APVD		
AF	50	A2	ECR-13-016672	25OCT13	PKS	RRP	

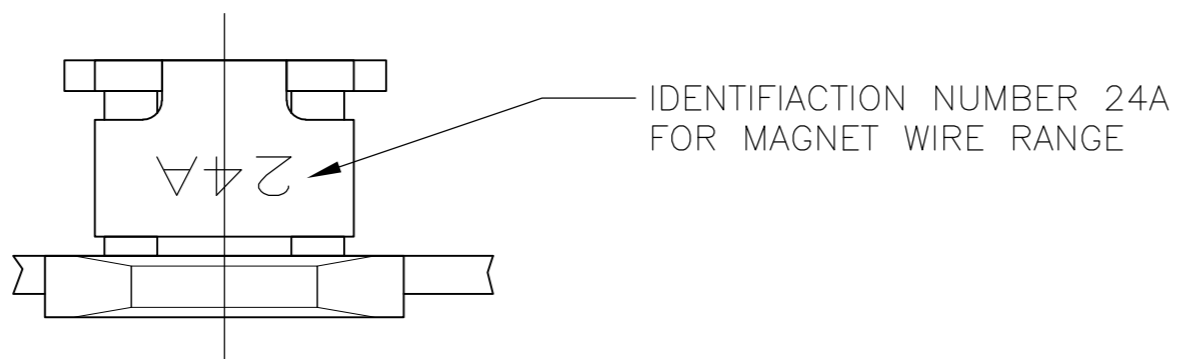

- 1 CONTINUOUS STRIP ON REELS WITH TERMINALS LOCATED ON $.220 \pm .003$ CENTERS
- 2 SLOT TERMINATES A SINGLE MAGNET WIRE ONLY. ALUMINUM RANGE: 0.97-1.22mm [#18.5-#16.5] AWG.
- 3 AFTER INSERTION INTO PLASTIC HOLDER TAB PORTION MUST BE BENT OVER 45° TO 90° OR POTTED-IN TO PREVENT PULL-OUT WHEN MATING RECEPTACLE IS DISCONNECTED.

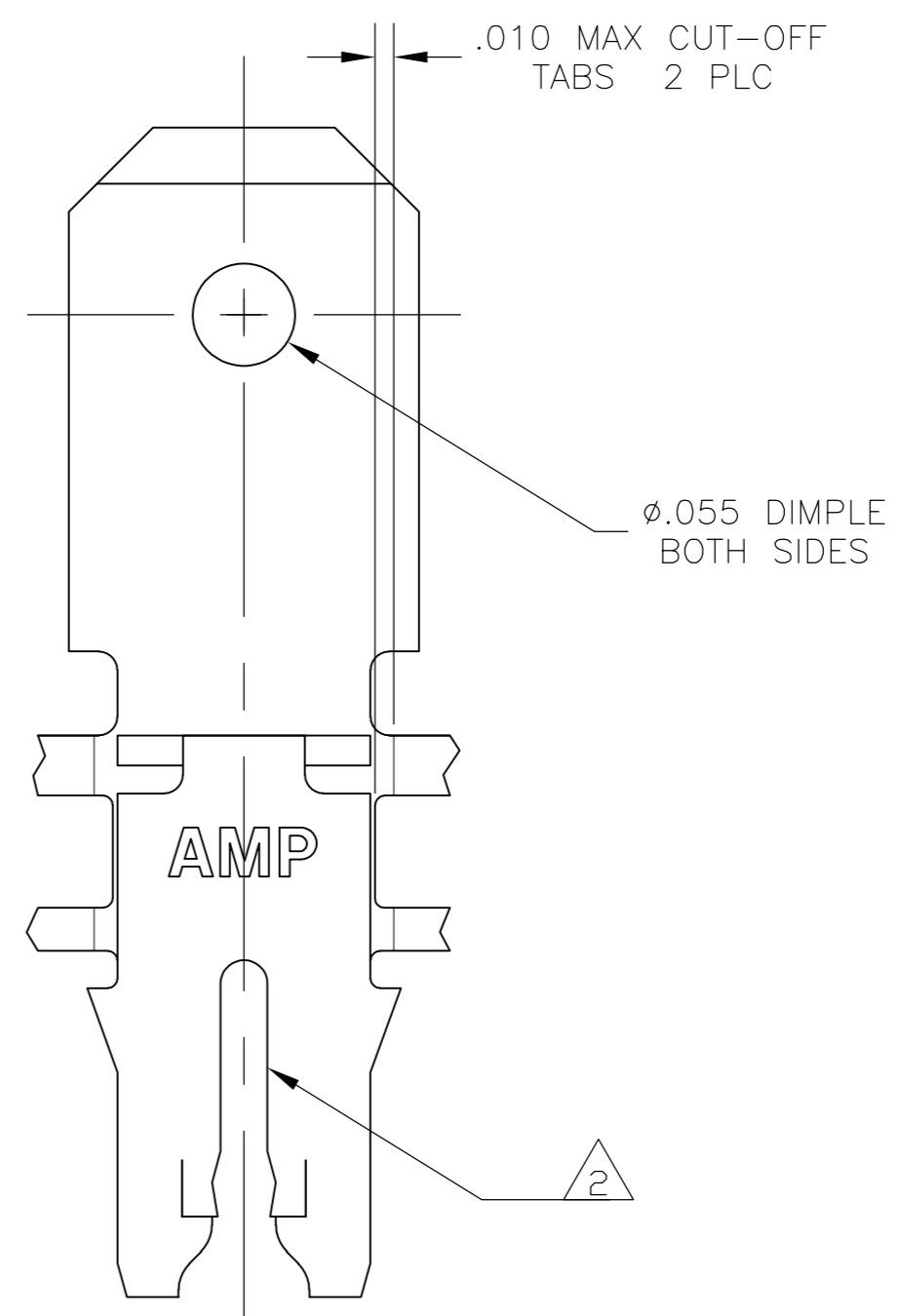
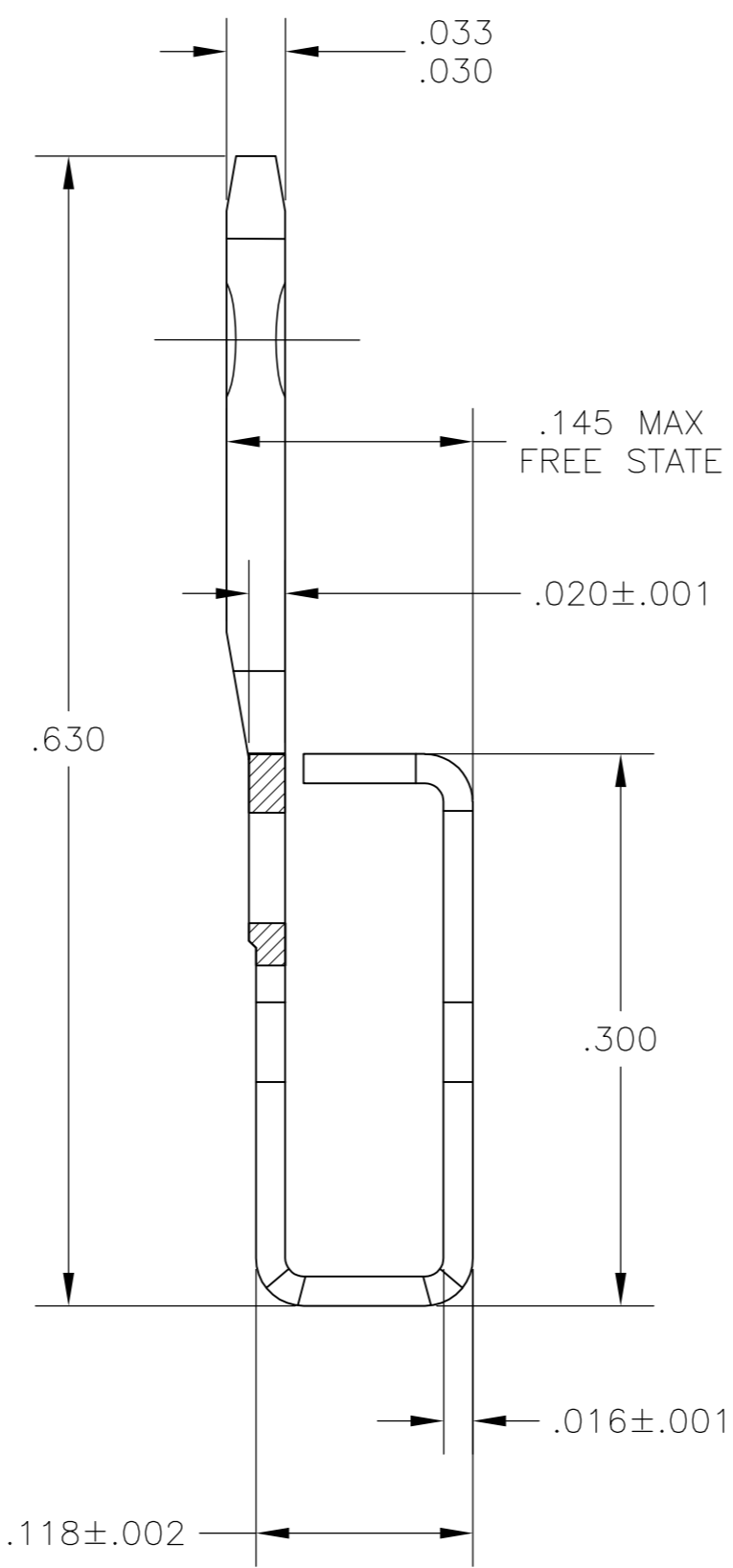
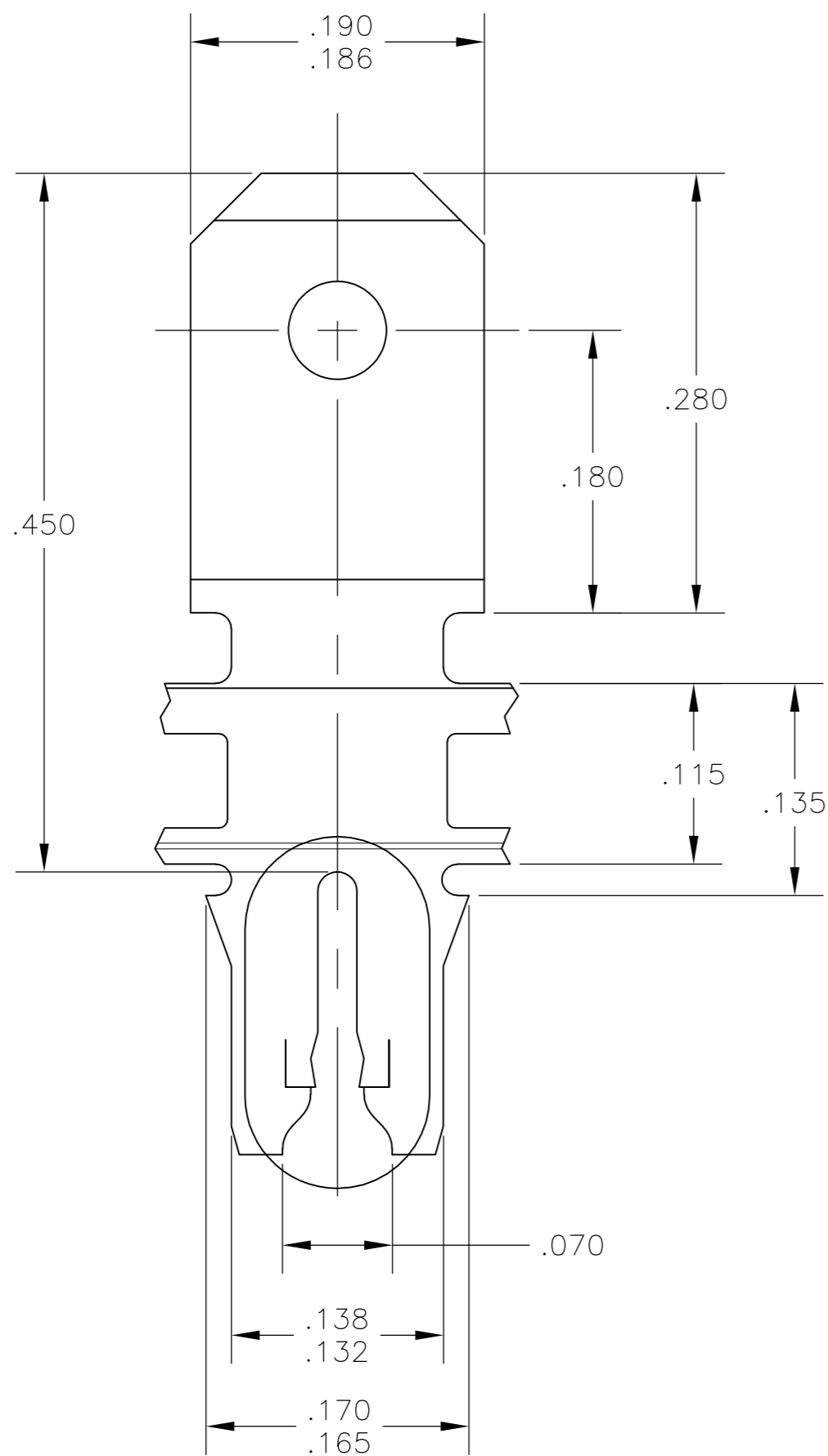

1742474-1
PART NO

THIS DRAWING IS A CONTROLLED DOCUMENT.		DWN jr ruth 12SEP06	TE TE Connectivity	
DIMENSIONS: INCHES		CHK K RANDOLPH 12SEP06		
TOLERANCES UNLESS OTHERWISE SPECIFIED:		APVD K RANDOLPH 12SEP06	NAME	
0 PLC ± -		PRODUCT SPEC	TERMINAL, TAB, .187 FASTON, MAG-MATE	
1 PLC ± -		APPLICATION SPEC	SIZE	CAGE CODE
2 PLC ± -		FINISH	A2	00779
3 PLC ± .010		MATERIAL	DRAWING NO	
4 PLC ± -		BRASS	C=1742474	
ANGLES ± 5°		FINISH	RESTRICTED TO	
TIN PLATE		WEIGHT	-	
CUSTOMER DRAWING		SCALE	10:1	
		SHEET	1 of 1	
		REV	A2	

单击下面可查看定价，库存，交付和生命周期等信息

[>>TE Connectivity\(泰科\)](#)