

THIS DRAWING IS UNPUBLISHED. RELEASED FOR PUBLICATION  
 © COPYRIGHT - BY TYCO ELECTRONICS CORPORATION. ALL RIGHTS RESERVED.

LOC	DIST	REVISIONS			
P	LTR	DESCRIPTION	DATE	DWN	APVD
G	02	A1	REV PER ECR 06-011374	19MAY06	JR TM

**AMP**  
 WIRE RANGE

22-16 AWG  
 SOLID OR STRANDED

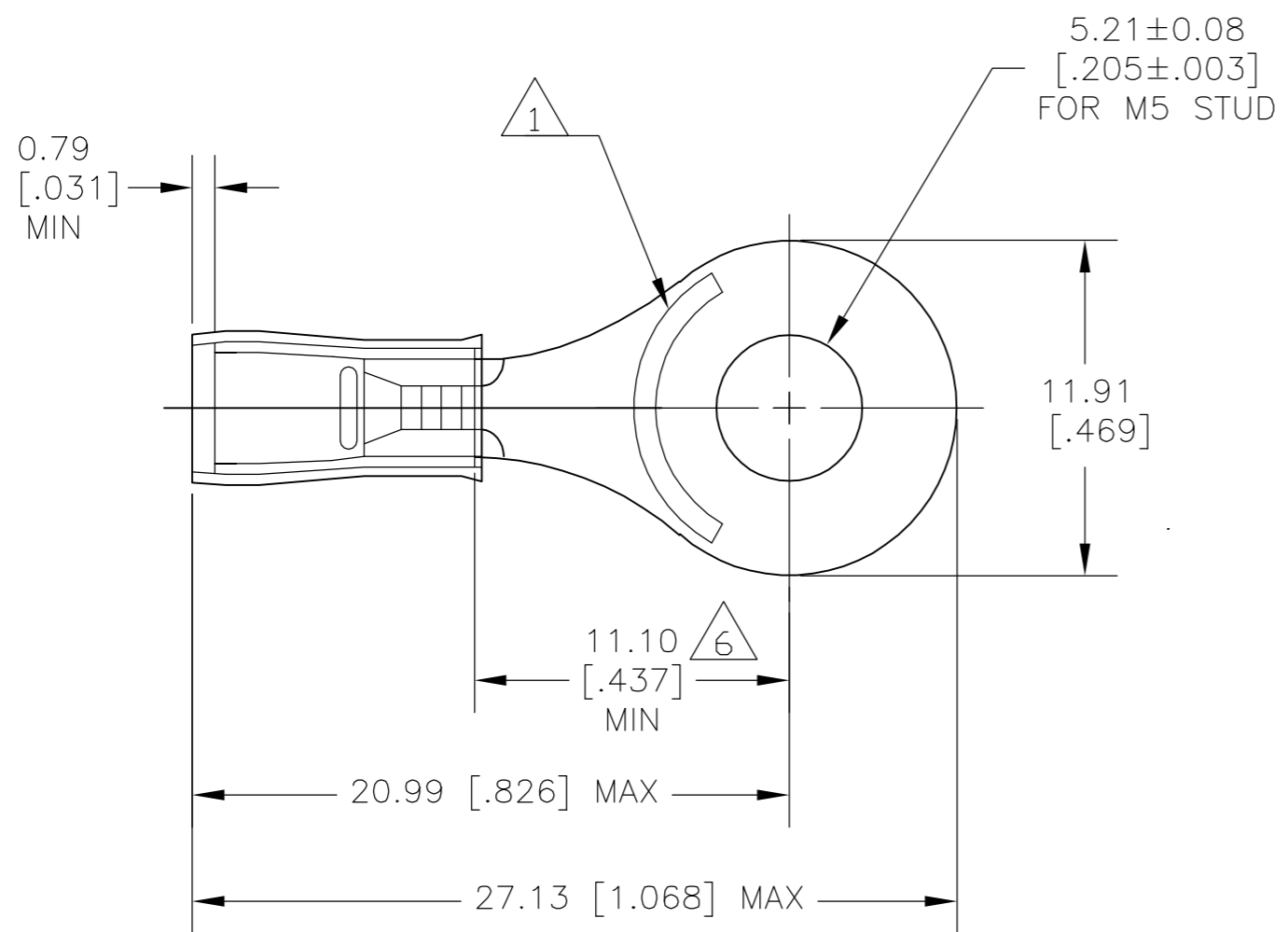

- 1 STAMP "AMP 22-18\*" APPROX AS SHOWN, 22-16 TERMINALS ARE STAMPED 22-18 IN ACCORDANCE WITH MILITARY SPECIFICATION MIL-T-7928, COMMERCIAL WIRE RANGE IS 22-16.
- 2 MATERIAL: TERMINAL & SLEEVE- COPPER PER ASTM B-152, ANNEALED. INSULATION - NYLON, COLOR RED
- 3 FINISH: TERMINAL & SLEEVE- 0.00254 [.000100] MIN TIN PLATE PER ASTM B-545
- 4 WIRE INSULATION DIA 2.03-3.18 [.080-.125]
- 5 TONGUE MATERIAL THK: 0.79±0.05 [.031±.002]
- 6 DIMENSION APPLIES FROM EDGE OF WIRE BARREL TO CENTER OF STUD HOLE.
- 7 MAX RECOMMENDED OPERATING TEMP 105°C [221°F]
- 8 VOLTAGE RATING IS 300 V MAX
- 9 0.26-1.65mm<sup>2</sup> [509-3,260] CMA, STRANDED

1000	LOOSE PIECE	130660
QTY	PACKAGING TYPE	PART NO

THIS DRAWING IS A CONTROLLED DOCUMENT.		DWN jr_ruth 19MAY06	Tyco Electronics Corporation Harrisburg, PA 17105-3608	
DIMENSIONS: MM [INCHES]		CHK T MICHIELUTTI 19MAY06		
TOLERANCES UNLESS OTHERWISE SPECIFIED:		APVD T MICHIELUTTI 19MAY06	NAME	
0 PLC ± - 1 PLC ± - 2 PLC ± - 3 PLC ± 0.20 [.008] 4 PLC ± - ANGLES ± -		PRODUCT SPEC	TERMINAL, RING TONGUE, PIDG, WIRE SIZE, 22-16 AWG	
MATERIAL - 2		APPLICATION SPEC	SIZE	RESTRICTED TO
FINISH - 3		WEIGHT -	CAGE CODE	
		CUSTOMER DRAWING	DRAWING NO	
		SCALE 4:1	SHEET 1 OF 1	REV A1

单击下面可查看定价，库存，交付和生命周期等信息

[>>TE Connectivity\(泰科\)](#)