

THIS DRAWING IS UNPUBLISHED. RELEASED FOR PUBLICATION
 © COPYRIGHT - By - ALL RIGHTS RESERVED.

LOC	DIST	REVISIONS					
		P	LTR	DESCRIPTION	DATE	DWN	APVD
G	14		E	REVISED PER ECO-14-015277	11FEB2015	NK	DR

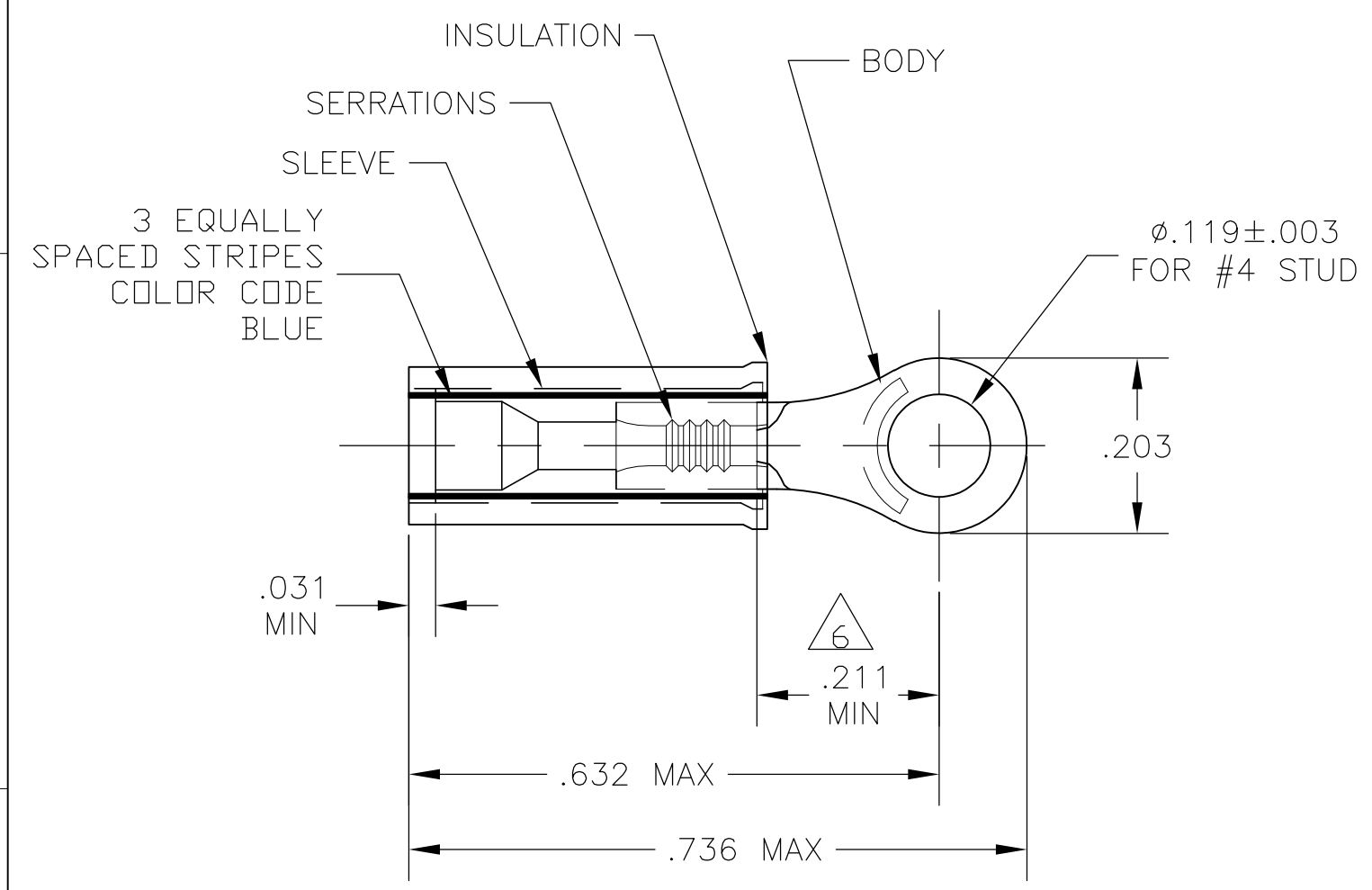

- 1 MUST BE CRIMPED WITH A 22-18 OR 22-16 PIDG (RED) TOOL.
- 2 WIRE INSULATION DIA: .031-.055.
- 3 TONGUE MATERIAL THK: .027±.002.
- 4 BODY & SLEEVE: TIN .000100 MIN EXT THK PER ASTM B545.
- 5 MATERIAL: BODY & SLEEVE- CU PER ASTM B152 INSULATION - NYLON PER ASTM D4066 COLOR - YELLOW.
- 6 APPLIES FROM EDGE OF METAL BBL TO THE CENTER OF STUD HOLE.
- 7 MEETS M7928/1-7, CLASS 1 & 2

1000	LOOSE PIECE	53054
QTY	PACKAGE TYPE	PART NO.

CUSTOMER SERVICE SYSTEMS		MAX RECOMMENDED OPERATING TEMPERATURE: 105°C MAX
FOR ADDITIONAL PRODUCT INFORMATION OR COPIES OF DRAWINGS AND TECHNICAL DOCUMENTS	PRODUCT INFORMATION CENTER 1-800-522-6752	VOLTAGE RATING: 300 V MAX
FOR APPLICATION TOOLING INFORMATION	TOOLING ASSISTANCE CENTER 1-800-722-1111	CIRCULAR MIL AREA: 0.10-0.26mm ² [202-509] STRANDED
FOR ORDER ENTRY	1-800-526-5142	

THIS DRAWING IS A CONTROLLED DOCUMENT.	
DIMENSIONS: INCHES	TOLERANCES UNLESS OTHERWISE SPECIFIED:
	0 PLC ± - 1 PLC ± - 2 PLC ± 0.20[.008] 3 PLC ± - 4 PLC ± - ANGLES ± -
MATERIAL	FINISH
4	5

DWN JR RUTH 14JAN10	STE TE Connectivity			
CHK T MICHELUTTI 15JAN10				
APVD T MICHELUTTI 15JAN10	NAME TERMINAL, RING TONGUE, PIDG, INSULATION RESTRICTING WIRE SIZE: 24 AWG			
PRODUCT SPEC ---	SIZE A3	CAGE CODE 00779	DRAWING NO C-53054	RESTRICTED TO ---
APPLICATION SPEC ---	CUSTOMER DRAWING		SCALE 4:1	SHEET 1 OF 1
WEIGHT -			REV E	

单击下面可查看定价，库存，交付和生命周期等信息

[>>TE Connectivity\(泰科\)](#)