

THIS DRAWING IS UNPUBLISHED.

RELEASED FOR PUBLICATION

ALL RIGHTS RESERVED.

© COPYRIGHT - By -

REVISIONS

P	LTR	DESCRIPTION	DATE	DWN	APVD
D		ECO-18-018694	22NOV2018	LL	SH

NOTE:

1. MATERIAL:
 - 1.1 HOUSING: PA9T WITH 30% GF, UL94 V-0, COLOR: BLACK.
 - 1.2 INSERT HOUSING: PA9T WITH 30% GF, UL94 V-0, COLOR: BLACK.
 - 1.3 CONTACTS: PHOSPHOR BRONZE.
 - 1.4 SHELL: BRASS.
 - 1.5 MYLAR: PI, THICKNESS=0.07mm, COLOR: YELLOW
2. FINISH:
 - 2.1 CONTACTS: (SEE TABLE) GOLD PLATED ON CONTACT AREA. GOLD FLASH ON SOLDER TAIL. 1.27um [50u"] MIN. NICKEL UNDERPLATED OVERALL.
 - 2.2 SHELL: 0.508um [20u"] MIN. NICKEL PLATED OVERALL.
3. REFLOW SOLDER COPABLE TO 260+/-5°C PEAK TEMPERATURE PER TE SPEC TEC-109-201, TEST METHOD A, CONDITION B.

TE LOGO & DATE CODE

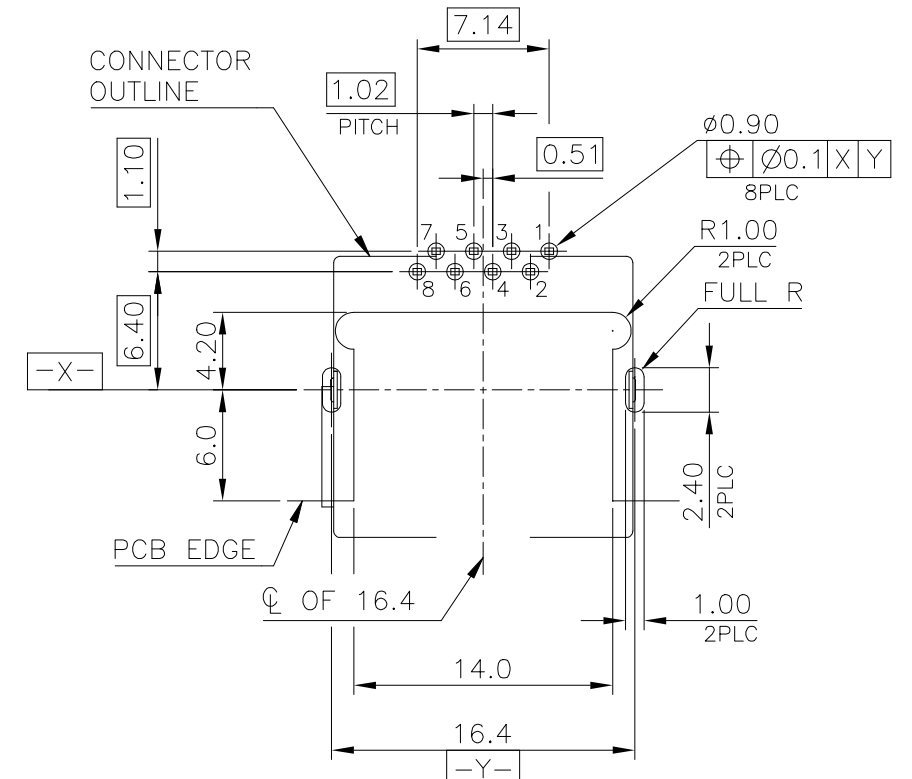
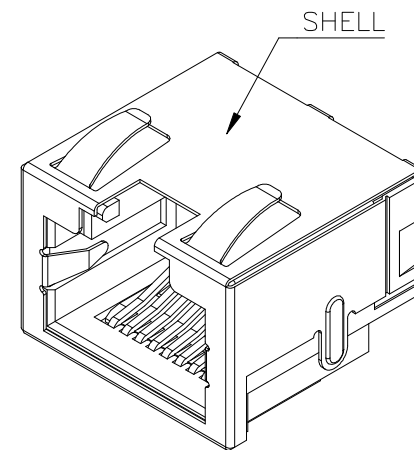
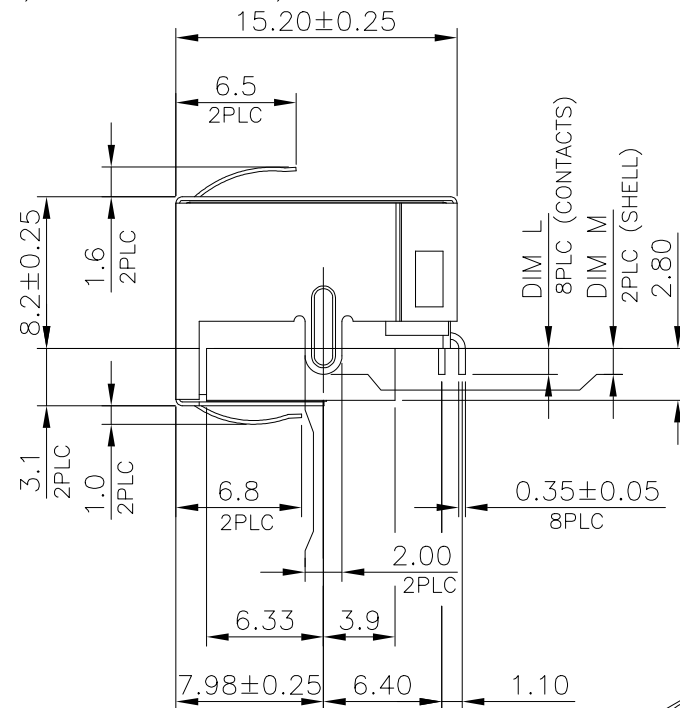
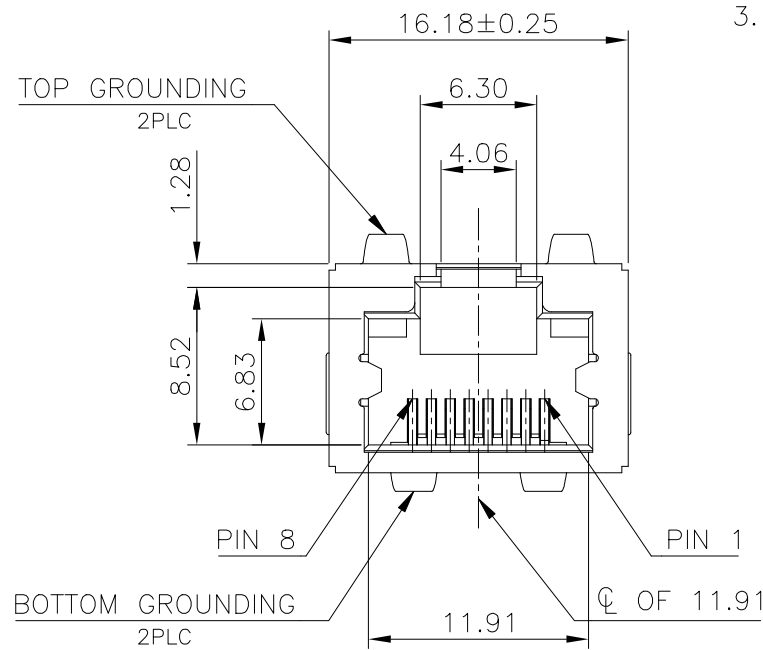
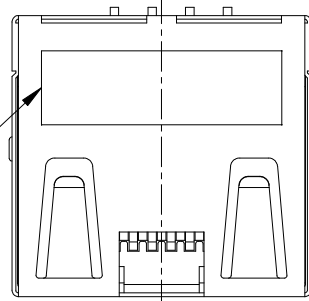

RECOMMENDED PCB LAYOUT (COMPONENT SIDE)
 TOLERANCE: ±0.05
 PCB THICKNESS: 1.2mm

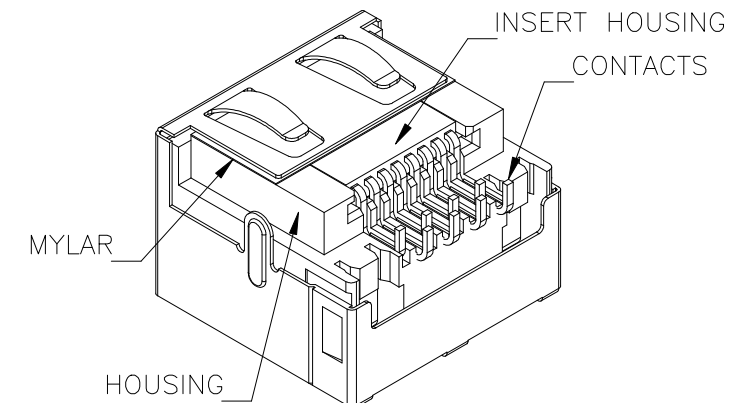

0.762um [30u"]	1.8	1.8	2041307-2
0.152um [6u"]	1.4	1.4	2041307-1
MIN. GOLD THICKNESS	DIM M	DIM L	PART NUMBER

MYLAR ATTACHED (UNDER SHELL)
 MYLAR NOT ALLOWED TO PROTRUDE FROM SHELL

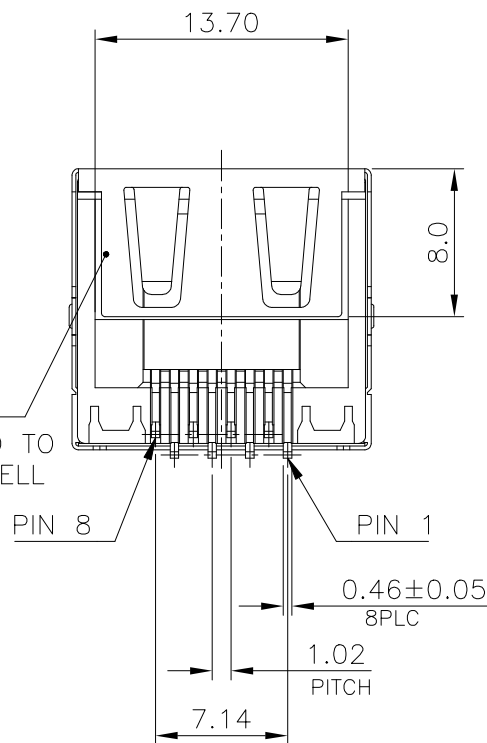

THIS DRAWING IS A CONTROLLED DOCUMENT.

DIMENSIONS:	TOLERANCES UNLESS OTHERWISE SPECIFIED:
mm	
0 PLC	± -
1 PLC	± 0.3
2 PLC	± 0.2
3 PLC	± 0.15
4 PLC	± -
ANGLES	± -
MATERIAL	FINISH
SEE NOTE	SEE NOTE

DWN	E. LIU	10JAN2011
CHK	S. CHIEN	10JAN2011
APVD	W. KODAMA	10JAN2011
PRODUCT SPEC	108-57847	
APPLICATION SPEC	-	
WEIGHT	2.91 GRAMS	
CUSTOMER DRAWING		



NAME			
MODULAR JACK CONN			
RJ45 W/O LED, TAB UP, SIDE ENTRY			
OFFSET, DIP TYPE, H=8.2MM			
SIZE	CAGE CODE	DRAWING NO	RESTRICTED TO
A3	00779	C=2041307	-
SCALE	SHEET	REV	
1:1	1 of 3	D	

4

3

2

1

THIS DRAWING IS UNPUBLISHED. RELEASED FOR PUBLICATION
 © COPYRIGHT - By - ALL RIGHTS RESERVED.

REVISIONS					
P	LTR	DESCRIPTION	DATE	DWN	APVD
-	-	SEE SHEET 1	-	-	-

- NOTES:
- MATERIAL:
 TRAY: PET
 TOP TRAY: PET
 BOX: CORRUGATED FIBER.
 - EACH BAG SHALL BE INCLUDED:
 *DESICCANT
 - DIMENSION: SEE DRAWING
 - QUANTITY: SEE TABLE
 - WEIGHT: SEE TABLE

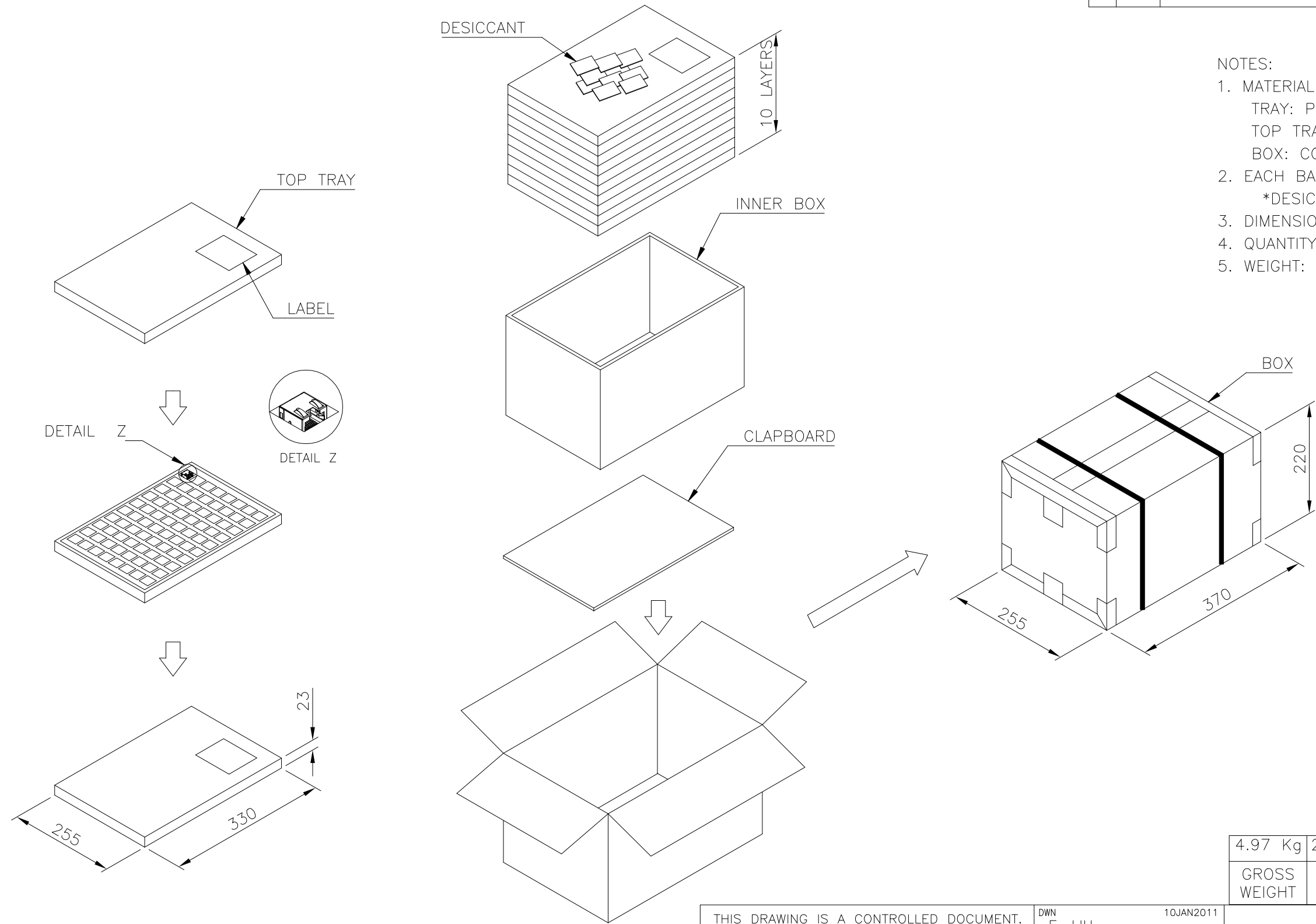

4.97 Kg	2.33 Kg	80	10	800	2041307-1
GROSS WEIGHT	NET WEIGHT	PCS/TRAY	TRAY/BOX	PCS/BOX	PART NUMBER

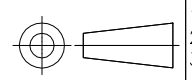
THIS DRAWING IS A CONTROLLED DOCUMENT.		DWN	E. LIU	10JAN2011	 TE Connectivity
DIMENSIONS: mm		CHK	S. CHIEN	10JAN2011	
		APVD	W. KODAMA	10JAN2011	
TOLERANCES UNLESS OTHERWISE SPECIFIED:		PRODUCT SPEC		NAME	
0 PLC ± - 1 PLC ± 0.3 2 PLC ± 0.2 3 PLC ± 0.15 4 PLC ± - ANGLES ± -		APPLICATION SPEC		108-57847	MODULAR JACK CONN RJ45 W/O LED, TAB UP, SIDE ENTRY OFFSET, DIP TYPE, H=8.2MM
MATERIAL SEE NOTE		FINISH SEE NOTE		WEIGHT -	
		SIZE	A3	CAGE CODE	00779
		DRAWING NO	C=2041307		RESTRICTED TO
		CUSTOMER DRAWING		SCALE	1:1
		SHEET		2 of 3	REV
				D	

THIS DRAWING IS UNPUBLISHED.

RELEASED FOR PUBLICATION

ALL RIGHTS RESERVED.

© COPYRIGHT - By -

REVISIONS

P	LTR	DESCRIPTION	DATE	DWN	APVD
-	-	SEE SHEET 1	-	-	-

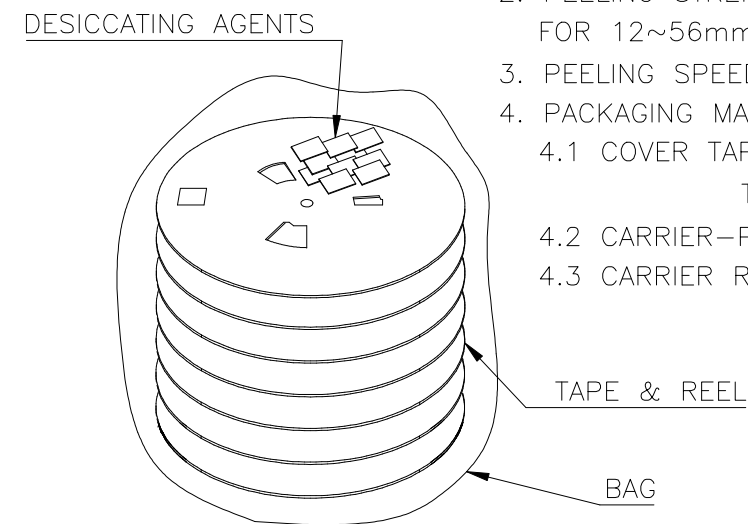
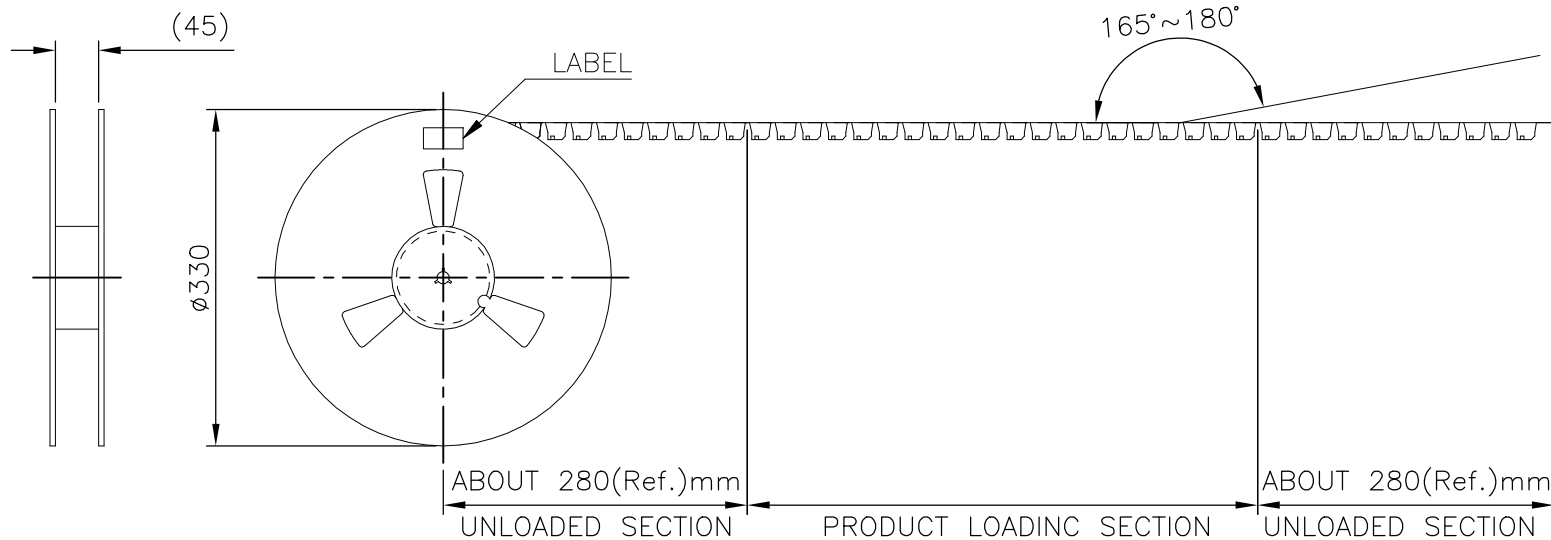

- NOTE:
- EACH BAG SHALL BE INCLUDED:
*DESICCANT
 - PEELING STRENGTH: 0.1~1.3N(1~130 GRAMS)
FOR 12~56mm WIDE CARRIER TAPES
 - PEELING SPEED: 300mm/MINUTES.
 - PACKAGING MATERIAL:
 - COVER TAPE-COMPOSITE OF POLYETHYLENE TEREPHTHALATE (PET)
 - CARRIER-POLYSTYRENE (PS)
 - CARRIER REEL-POLYSTYRENE

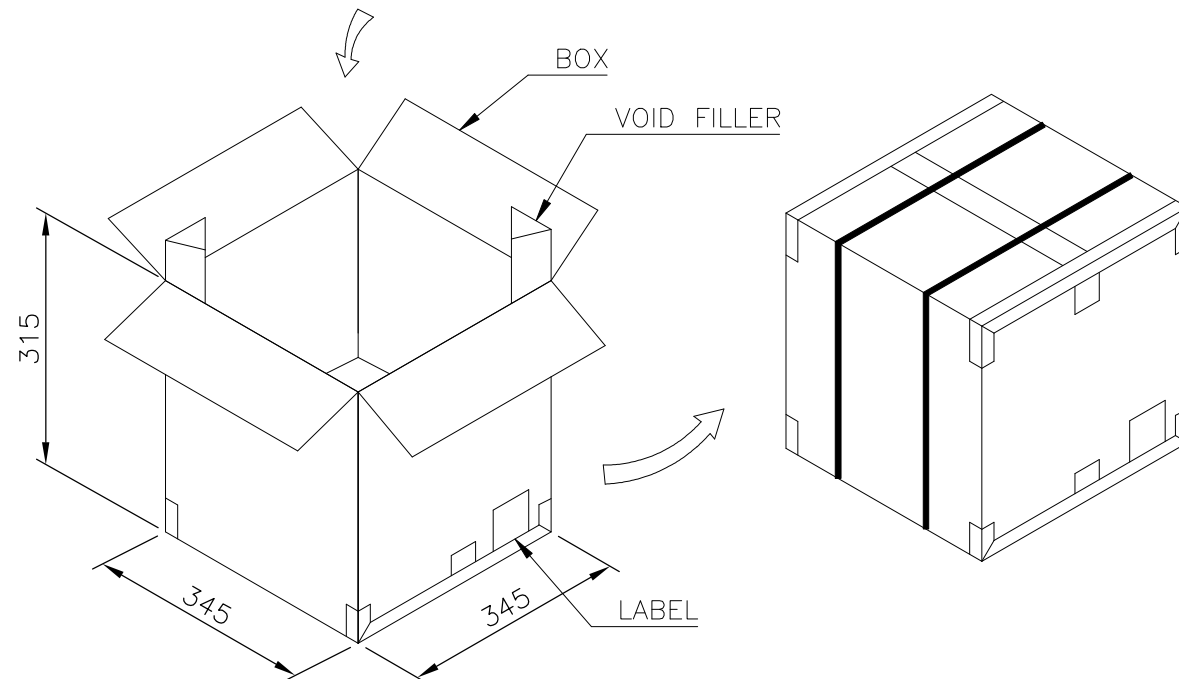
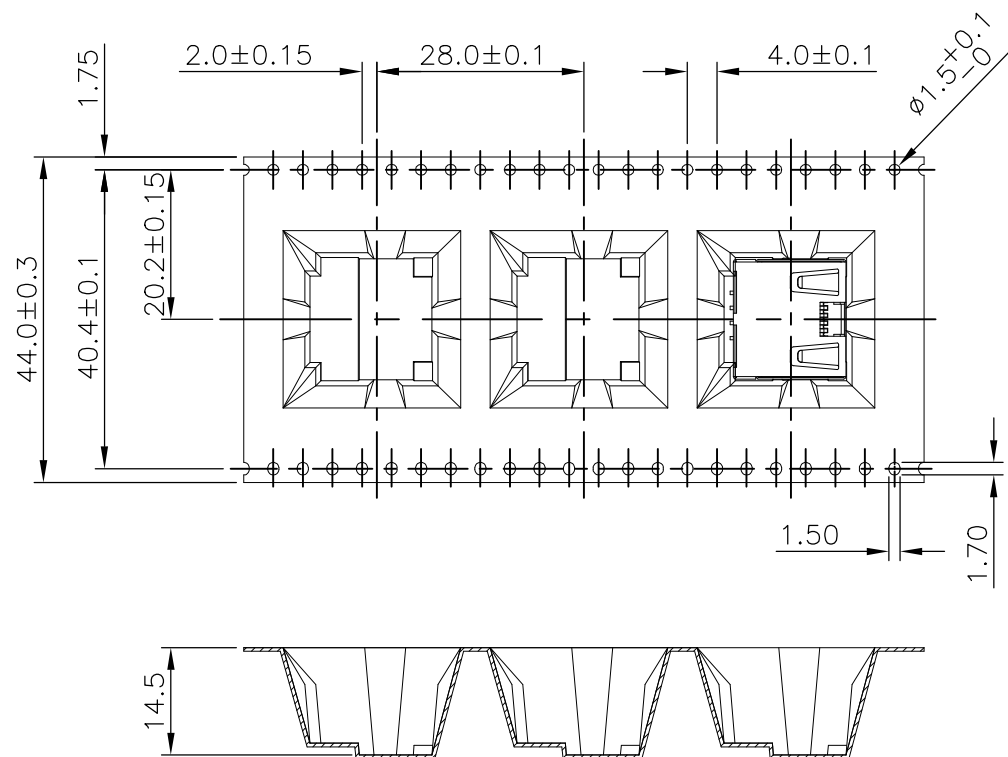

5.8 Kg	2.62Kg	150	6	900	2041307-2
GROSS WEIGHT	NET WEIGHT	PCS/ REEL	REEL/ BOX	PCS/ BOX	PART NUMBER

THIS DRAWING IS A CONTROLLED DOCUMENT.		DWN	E. LIU	10JAN2011	 TE Connectivity											
DIMENSIONS: mm		CHK	S. CHIEN	10JAN2011												
TOLERANCES UNLESS OTHERWISE SPECIFIED:		APVD	W. KODAMA	10JAN2011												
<table border="0"> <tr><td>0 PLC</td><td>± -</td></tr> <tr><td>1 PLC</td><td>± 0.3</td></tr> <tr><td>2 PLC</td><td>± 0.2</td></tr> <tr><td>3 PLC</td><td>± 0.15</td></tr> <tr><td>4 PLC</td><td>± -</td></tr> <tr><td>ANGLES</td><td>± -</td></tr> </table>		0 PLC	± -	1 PLC		± 0.3	2 PLC	± 0.2	3 PLC	± 0.15	4 PLC	± -	ANGLES	± -	PRODUCT SPEC	108-57847
0 PLC	± -															
1 PLC	± 0.3															
2 PLC	± 0.2															
3 PLC	± 0.15															
4 PLC	± -															
ANGLES	± -															
MATERIAL		APPLICATION SPEC	NAME													
SEE NOTE		FINISH	MODULAR JACK CONN													
		WEIGHT	RJ45 W/O LED, TAB UP, SIDE ENTRY													
			OFFSET, DIP TYPE, H=8.2MM													
			SIZE	CAGE CODE	DRAWING NO	RESTRICTED TO										
			A3	00779	C-2041307	-										
			CUSTOMER DRAWING		SCALE	1:1										
			SHEET		3 of 3	REV										
						D										

单击下面可查看定价，库存，交付和生命周期等信息

[>>TE Connectivity\(泰科\)](#)