

THIS DRAWING IS UNPUBLISHED. RELEASED FOR PUBLICATION
 © COPYRIGHT BY TYCO ELECTRONICS CORPORATION. ALL INTERNATIONAL RIGHTS RESERVED.

LOC		DIST		REVISIONS			
P	LTR	DESCRIPTION	DATE	DWN	APVD		
GP	00	N	REVISED PER ECO-08-008114	1JUL2008	ZMRC	CWR	

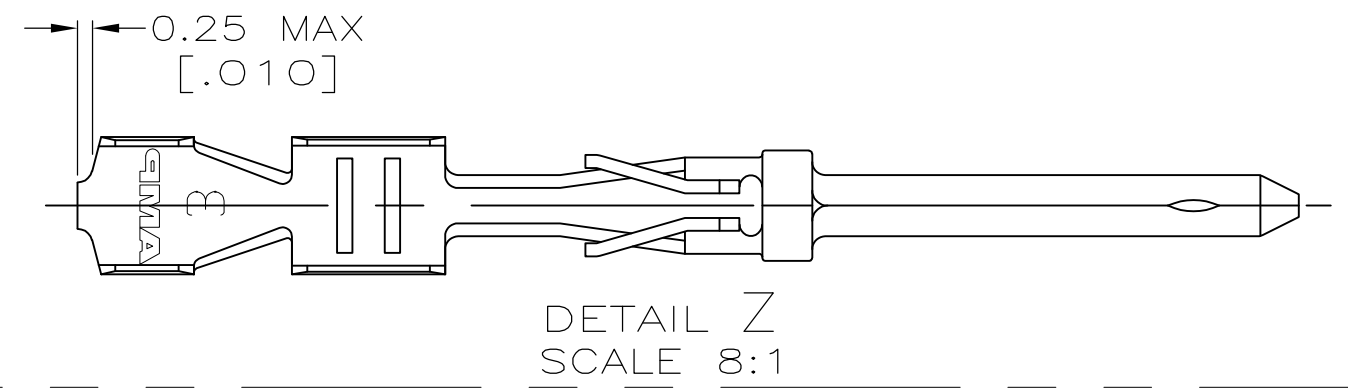

- 1 GOLD PLATING PER MIL-G-45204, TIN PLATING PER MIL-T-10727, NICKEL PLATING PER QQ-N-290.
- 2 GOLD PLATED IN LOCALIZED GOLD PLATE AREA, 0.76µm [.000030] MIN GOLD IN MATED AREA, 2.54µm [.000100] MIN BRIGHT TIN OR BRIGHT TIN-LEAD IN MIN LOCALIZED TIN PLATE AREA, ALL OVER 1.27µm [.000050] MIN NICKEL.
- 3 GOLD PLATED IN LOCALIZED GOLD PLATE AREA, GOLD FLASH IN MATED AREA, 2.54µm [.000100] MIN BRIGHT TIN OR BRIGHT TIN-LEAD IN MIN LOCALIZED TIN PLATE AREA, ALL OVER 0.76µm [.000030] MIN NICKEL.
- 4 GOLD PLATED IN LOCALIZED GOLD PLATE AREA, 0.76µm [.000030] MIN GOLD IN MATED AREA, 2.54µm [.000100] MIN MATTE TIN IN LOCALIZED TIN PLATE AREA, ALL OVER 1.27µm [.000050] MIN NICKEL UNDERPLATE.
OR
GOLD PLATED IN LOCALIZED GOLD PLATE AREA, GOLD FLASH OVER PALLADIUM-NICKEL, 0.76µm [.000030] MIN TOTAL IN MATED AREA, 2.54µm [.000100] MIN MATTE TIN IN LOCALIZED TIN PLATE AREA, ALL OVER 1.27µm [.000050] MIN NICKEL UNDERPLATE.
- 5 PHOSPHOR BRONZE PER QQ-B-750.

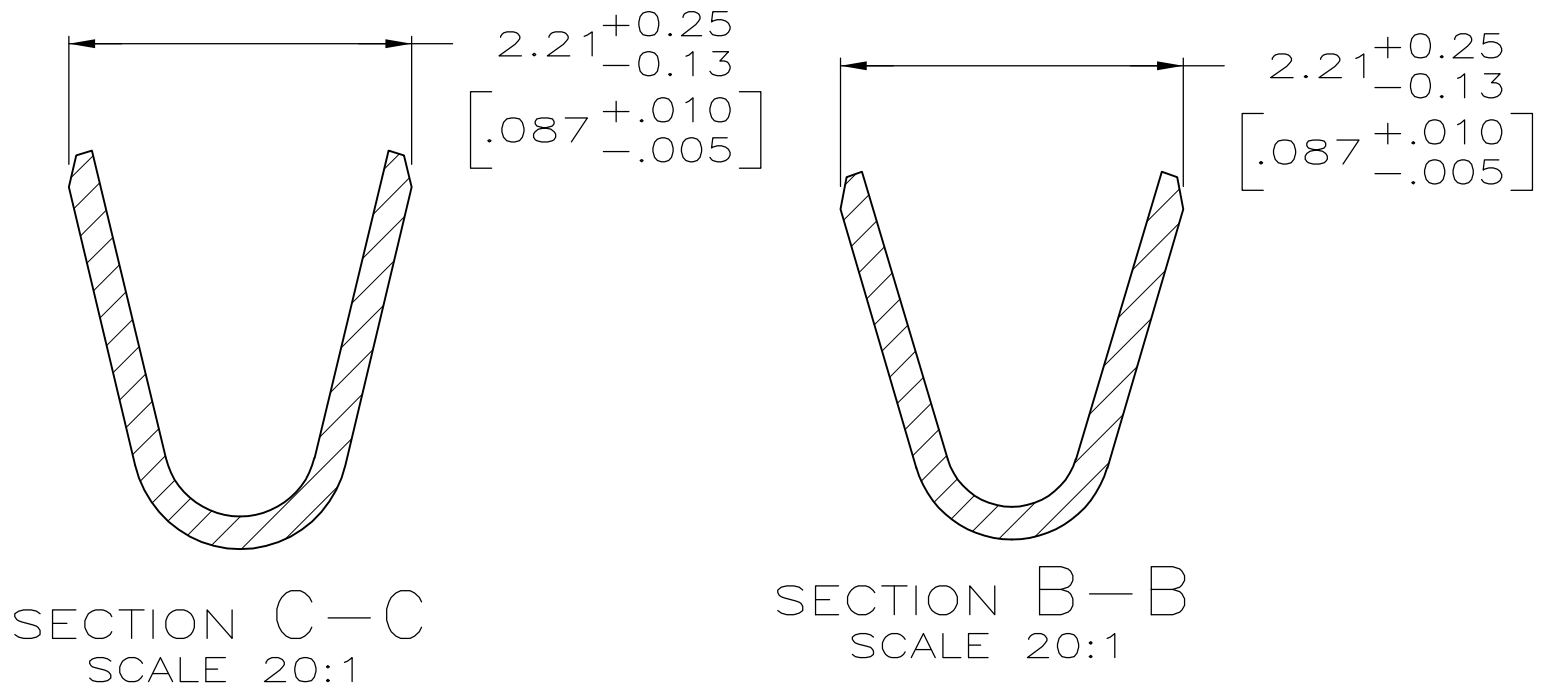
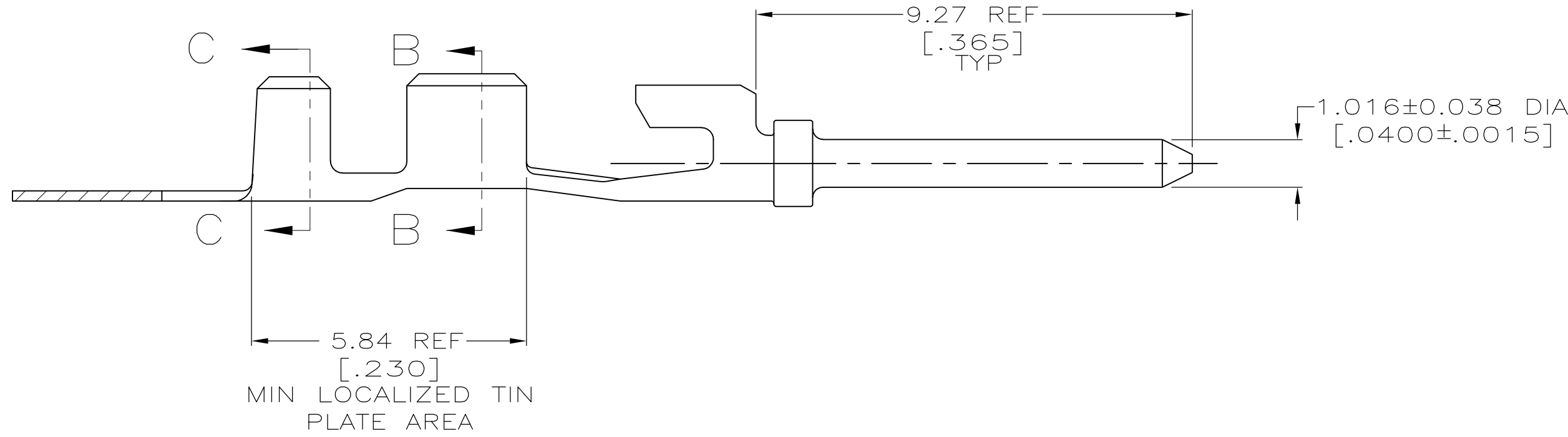
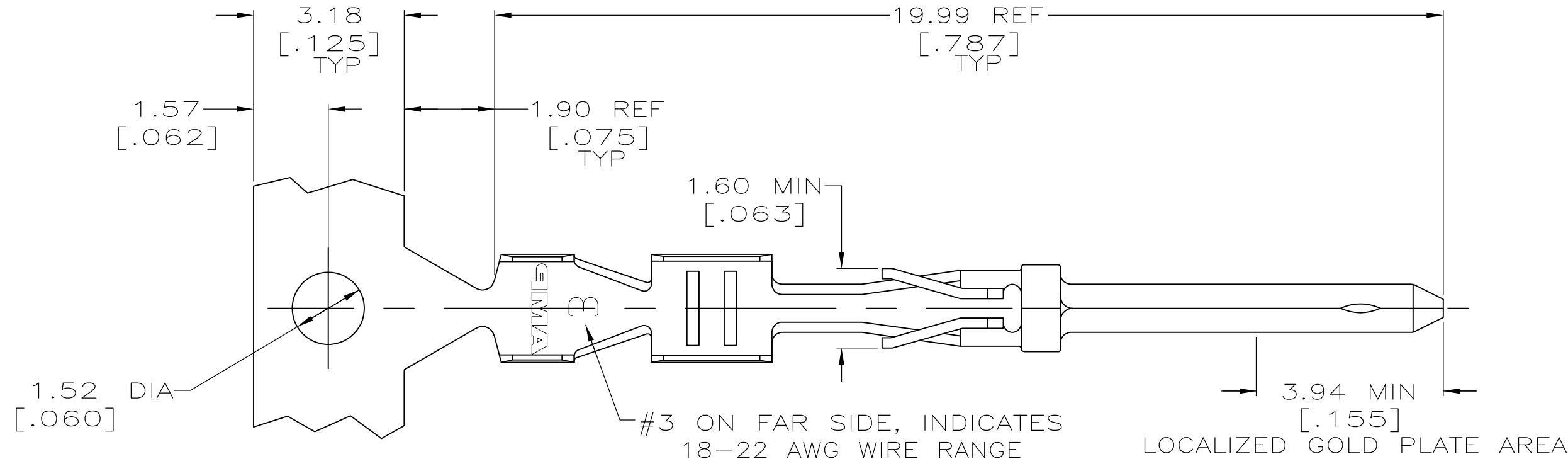

SUPERSEDED BY 745267-3	4	-	1-745267-0
SUPERSEDED BY 745267-2	-	DETAIL Z	745267-9
OBSOLETE	3	DETAIL Z	745267-8
OBSOLETE	3	-	745267-7
SUPERSEDED BY 745267-7	-	DETAIL Z	745267-6
SUPERSEDED BY 745267-6	-	-	745267-5
OBSOLETE	2	DETAIL Z	745267-4
OBSOLETE	2	-	745267-3
			745267-2
	FINISH	LOOSE PIECE	PART NO

THIS DRAWING IS A CONTROLLED DOCUMENT.		DWN L. VARELA - DOCK5 11-15-04	Tyco Electronics Corporation Harrisburg, PA 17105-3608	
DIMENSIONS: mm [INCHES]		CHK J. GERACE 11-15-04	NAME CONTACT PIN, OPEN BARREL, #18-22, HDE-20, AMPLIMITE	
TOLERANCES UNLESS OTHERWISE SPECIFIED:		APVD M. WALMSLEY 11-15-04	SIZE A2 CAGE CODE 00779 C=745267	
0 PLC ± -	1 PLC ± -	PRODUCT SPEC 108-40011	DRAWING NO -	
2 PLC ± 0.13 [.005]	3 PLC ± -	APPLICATION SPEC 114-40003	RESTRICTED TO -	
4 PLC ± -	ANGLES ± -	WEIGHT -	SCALE 10:1 SHEET 1 of 1 REV N	
MATERIAL 5	FINISH 1 SEE TABLE	CUSTOMER DRAWING		

单击下面可查看定价，库存，交付和生命周期等信息

[>>TE Connectivity\(泰科\)](#)