

LOC	DIST	REVISIONS			
DF	AO	REV	DESCRIPTION	DATE	BY
A		REVISED PER	ECO-13-002047	05FEB2013	MGM CT

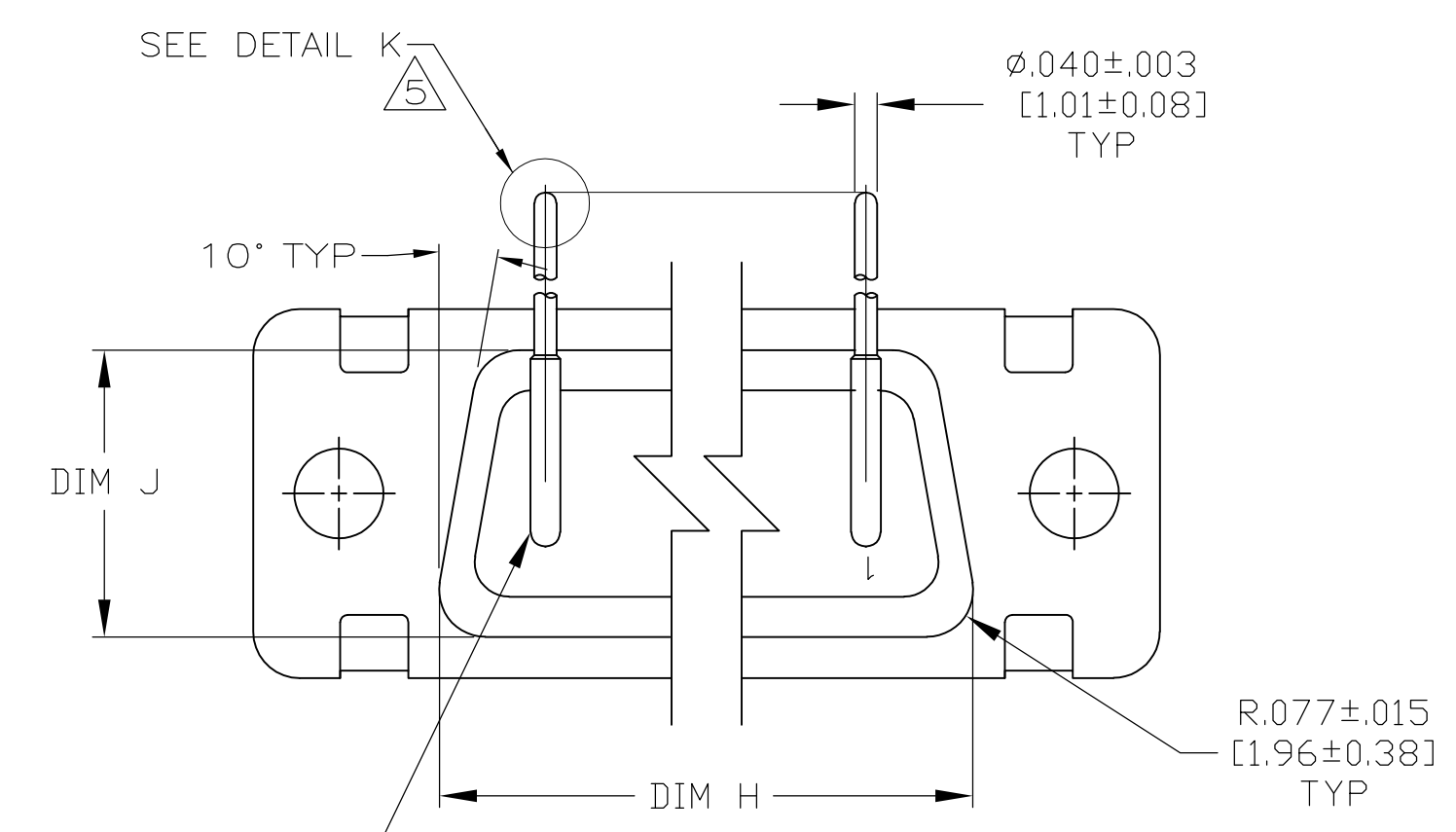
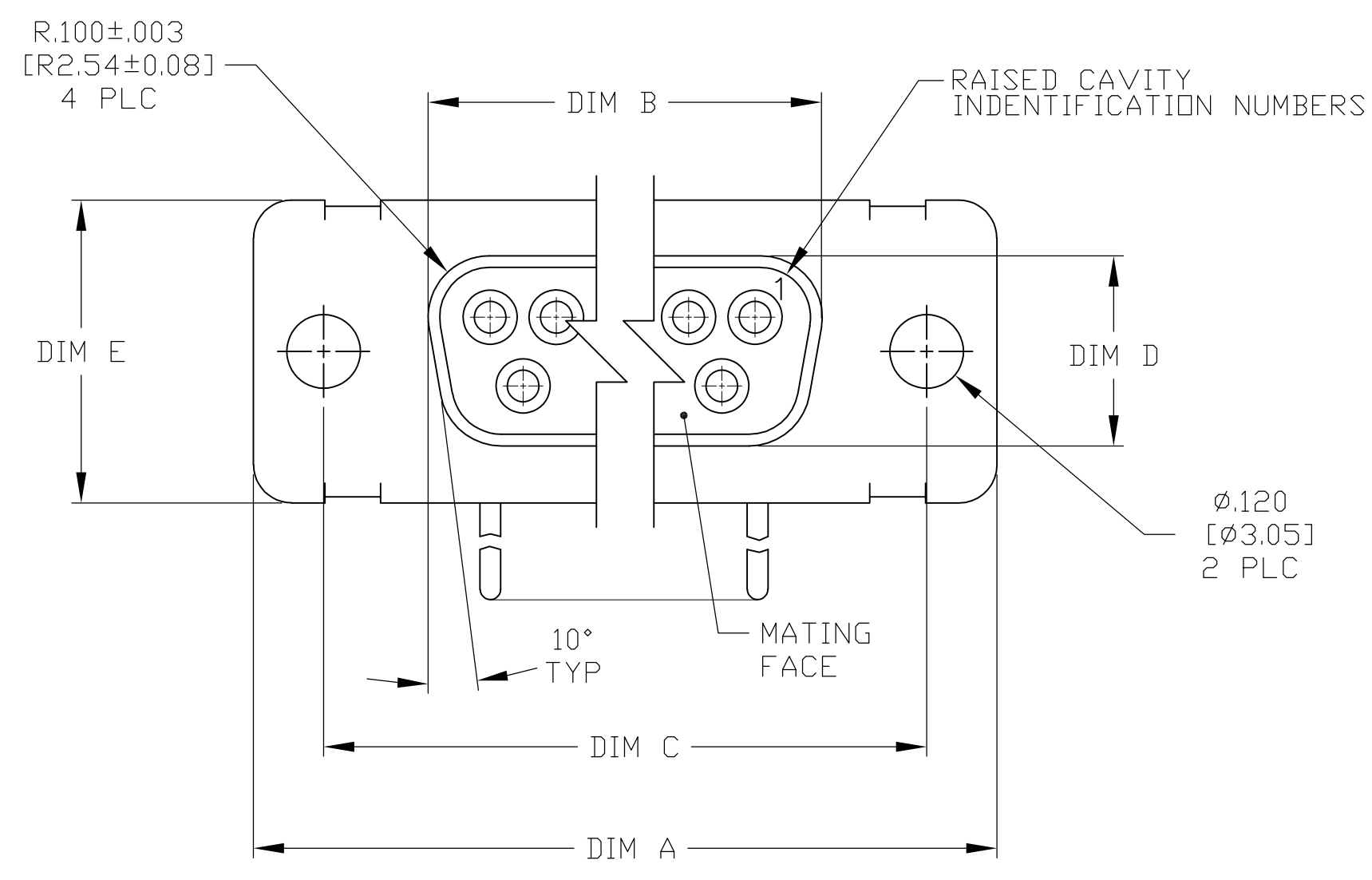

VIEW Z-Z
SHOWN WITH BRACKET REMOVED FOR CLARITY

CONTACT (QTY = NO. OF POSN)
MATL: BRASS PER ASTM-B-16, OR BERYLLIUM COPPER PER ASTM-B-194
FINISH: GOLD PER ASTM-B-488, TYPE II, GRADE C, CLASS 1.27 IN CONTACT MATING AREA, .000010 [0.0003] MIN THK GOLD PER ASTM-B-488 OVER .000050 [0.0013] MIN THK NICKEL PER SAE-AMS-QQ-N-290 ON CONTACT BODY

1. SEE SHEET 2 FOR RECOMMENDED P.C. BOARD LAYOUT. TRUE POSITION TOLERANCE FOR P.C. BOARD LAYOUT IS .010 [0.25] AT MAX MATERIAL CONDITION. SUGGESTED BOARD THICKNESS IS .062 [1.57]
2. THE CONNECTORS DESCRIBED IN THIS DOCUMENT MEET THE REQUIREMENTS OF MIL-C-24308 AND MATE WITH ANY PLUG CONNECTOR WITH SAME INSERT ARRANGEMENT.
3. MARKED WITH .047 [1.19]-.062 [1.57] HIGH CHARACTERS. FAR SIDE REFERS TO THE WIDE SIDE OF THE KEYSTONE. NEAR SIDE REFERS TO THE NARROW SIDE OF THE KEYSTONE. IF THE REAR SHELL IS TOO SMALL FOR THE ENTIRE MILITARY PART NUMBER, MARKING SHALL BE LOCATED AS FOLLOWS:
 - A. "M24308" ON FRONT SHELL, FAR SIDE.
 - B. SLASH SHEET AND DASH NUMBER ON REAR SHELL, FAR SIDE.
 - C. "TYCO" AND DATE CODE ON FRONT SHELL, NEAR SIDE.
 - D. TYCO PART NUMBER ON REAR SHELL, NEAR SIDE.
 IF THE FRONT SHELL IS TOO SMALL FOR "TYCO", TYCO PART NUMBER AND DATE CODE, MARKING SHALL BE SPLIT AS FOLLOWS:
 - A. TYCO PART NUMBER ON REAR SHELL, NEAR SIDE.
 - B. "TYCO" AND DATE CODE ON FRONT SHELL, NEAR SIDE.
 - C. MILITARY PART NUMBER ON REAR SHELL, FAR SIDE.
4. POINT OF ELECTRICAL ENGAGEMENT - AS MEASURED WITH A .0390-.0393 [0.991-0.998] DIA SQUARE ENDED PIN.
5. SOLDER DIPPED PER J-STD-001 WITH Sn63 SOLDER PER J-STD-006 IN THE ENTIRE AREA OF DIMENSION SHOWN. (1757842-6 THRU -10 ONLY.)
6. MEETS SOLDERABILITY PER MIL-STD-202 METHOD 208.

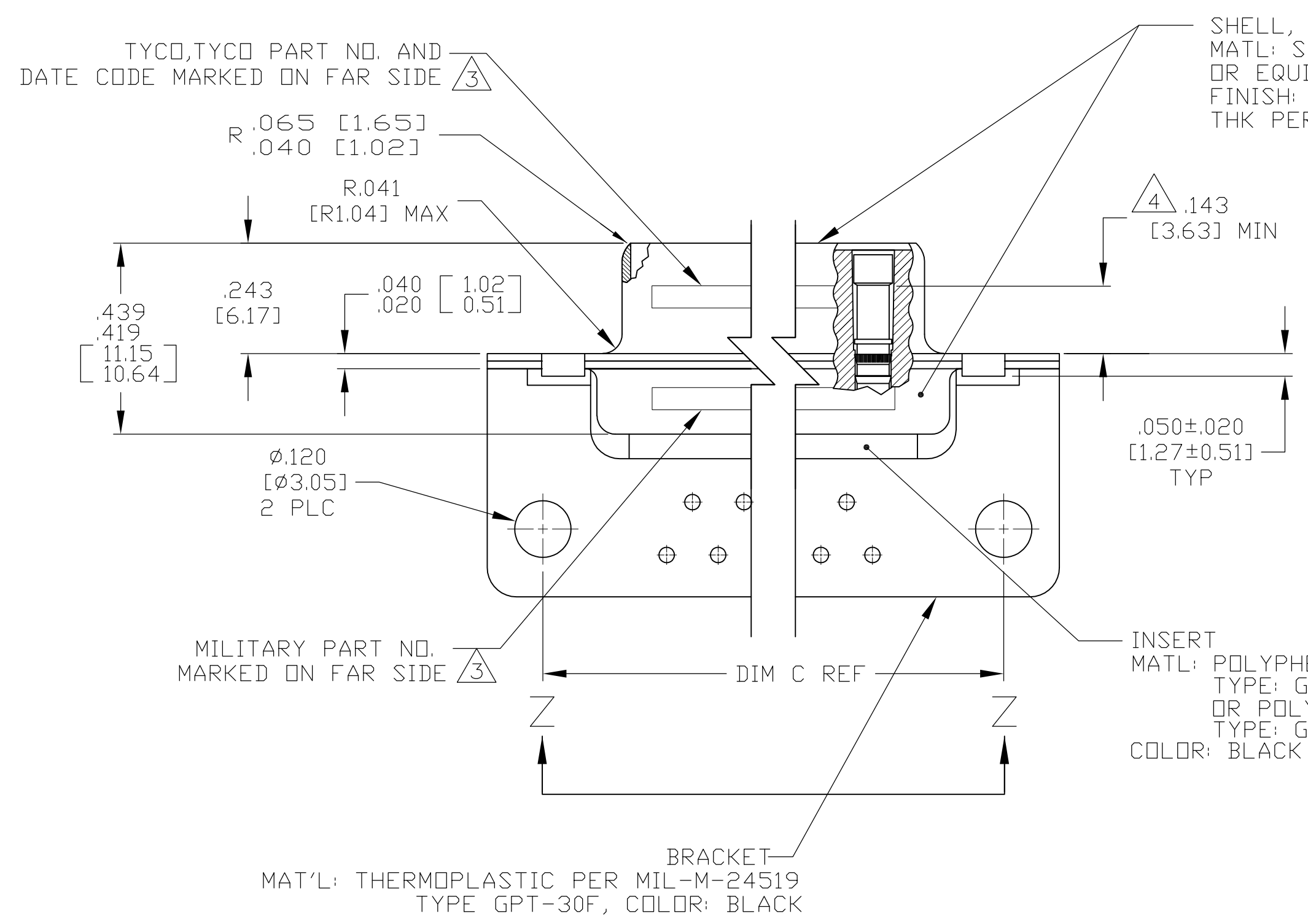

SHELL, FRONT & REAR
MATL: STEEL PER ASTM A 109 OR EQUIVALENT
FINISH: ZINC PLATED .000200 [0.0051] MIN THK PER ASTM-B-633; YELLOW CHROMATE

INSERT
MATL: POLYPHENYLENE SULFIDE (PPS) TYPE: GST-40F PER MIL-M-24519, OR POLYESTER PER MIL-M-24519, TYPE: GLCP-30F
COLOR: BLACK

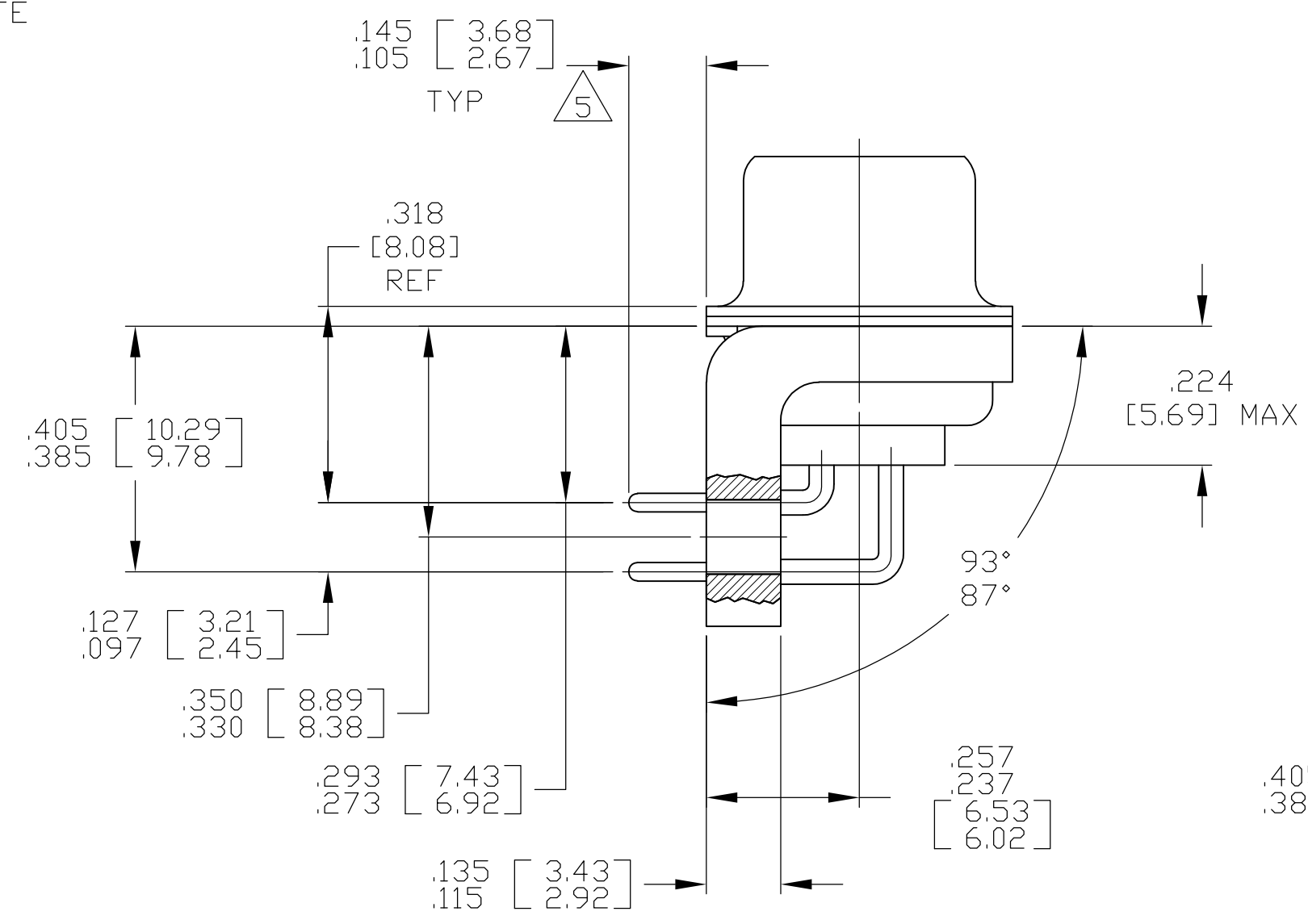

SHELL SIZES 1 THRU 4 CONTACT CONFIGURATION

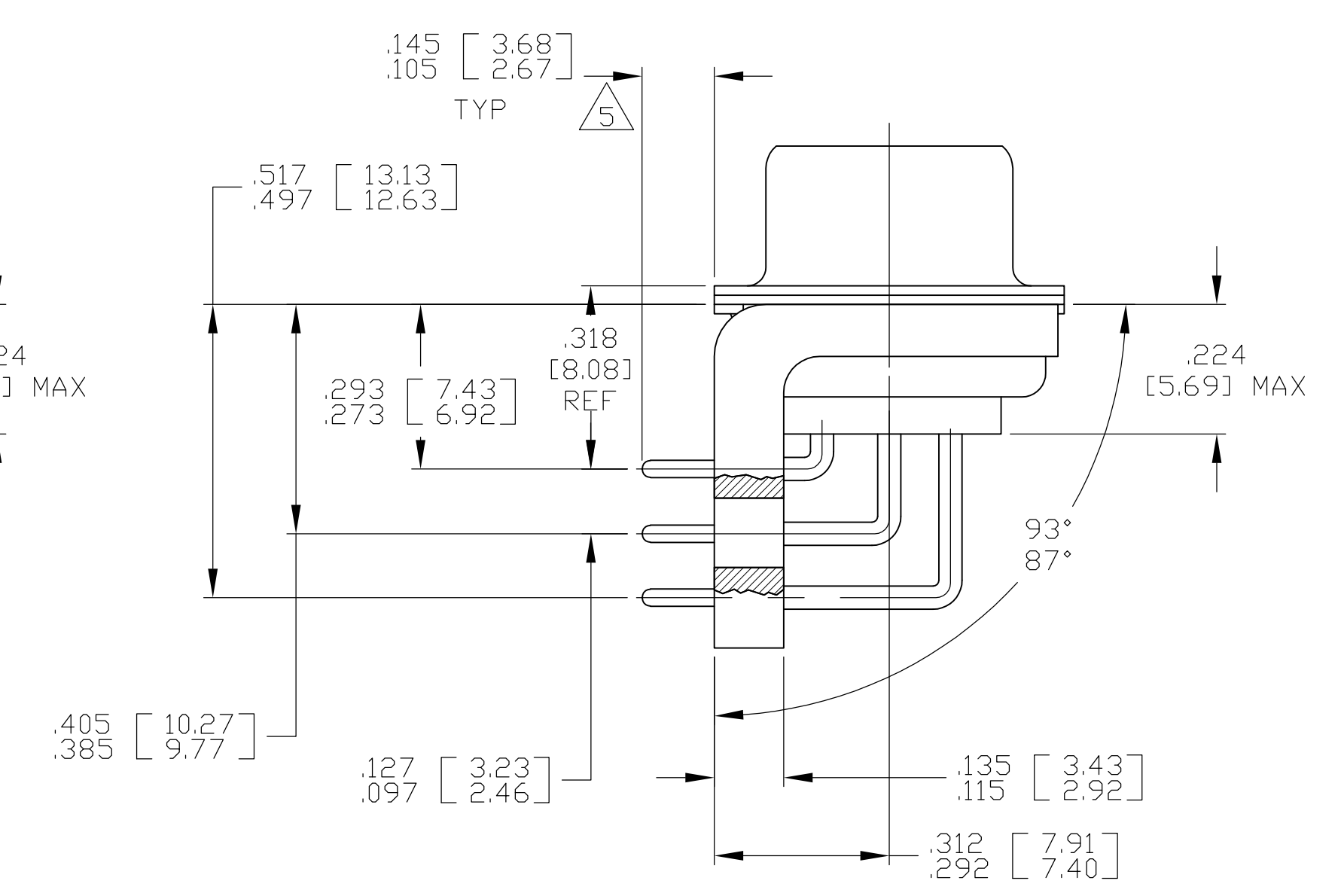

SHELL SIZE 5 CONTACT CONFIGURATION

.544 [13.82]	2.188 [55.58]	.620 [15.75]	.428 [10.87]	2.411 [61.24]	2.069 [52.55]	2.650 [67.31]
.524 [13.31]	2.168 [55.07]	.590 [14.99]	.418 [10.62]	2.401 [60.99]	2.059 [52.30]	2.620 [66.55]
.432 [10.97]	2.282 [57.96]	.509 [12.93]	.316 [8.03]	2.505 [63.63]	2.164 [54.97]	2.744 [69.70]
.412 [10.46]	2.262 [57.45]	.479 [12.17]	.306 [7.77]	2.495 [63.37]	2.154 [54.71]	2.714 [68.94]
.432 [10.97]	1.635 [41.53]	.509 [12.93]	.316 [8.03]	1.857 [47.17]	1.516 [38.51]	2.103 [53.42]
.412 [10.46]	1.615 [41.02]	.479 [12.17]	.306 [7.77]	1.847 [46.91]	1.506 [38.25]	2.073 [52.65]
.432 [10.97]	1.093 [27.76]	.509 [12.93]	.316 [8.03]	1.317 [33.45]	.976 [24.79]	1.556 [39.52]
.412 [10.46]	1.073 [27.25]	.479 [12.17]	.306 [7.77]	1.307 [33.20]	.966 [24.54]	1.526 [38.76]
.432 [10.97]	.769 [19.53]	.509 [12.93]	.316 [8.03]	.989 [25.12]	.648 [16.46]	1.228 [31.19]
.412 [10.46]	.749 [19.02]	.479 [12.17]	.306 [7.77]	.979 [24.87]	.638 [16.21]	1.198 [30.43]
.544 [13.82]	2.188 [55.58]	.620 [15.75]	.428 [10.87]	2.411 [61.24]	2.069 [52.55]	2.650 [67.31]
.524 [13.31]	2.168 [55.07]	.590 [14.99]	.418 [10.62]	2.401 [60.99]	2.059 [52.30]	2.620 [66.55]
.432 [10.97]	2.282 [57.96]	.509 [12.93]	.316 [8.03]	2.505 [63.63]	2.164 [54.97]	2.744 [69.70]
.412 [10.46]	2.262 [57.45]	.479 [12.17]	.306 [7.77]	2.495 [63.37]	2.154 [54.71]	2.714 [68.94]
.432 [10.97]	1.635 [41.53]	.509 [12.93]	.316 [8.03]	1.857 [47.17]	1.516 [38.51]	2.103 [53.42]
.412 [10.46]	1.615 [41.02]	.479 [12.17]	.306 [7.77]	1.847 [46.91]	1.506 [38.25]	2.073 [52.65]
.432 [10.97]	1.093 [27.76]	.509 [12.93]	.316 [8.03]	1.317 [33.45]	.976 [24.79]	1.556 [39.52]
.412 [10.46]	1.073 [27.25]	.479 [12.17]	.306 [7.77]	1.307 [33.20]	.966 [24.54]	1.526 [38.76]
.432 [10.97]	.769 [19.53]	.509 [12.93]	.316 [8.03]	.989 [25.12]	.648 [16.46]	1.228 [31.19]
.412 [10.46]	.749 [19.02]	.479 [12.17]	.306 [7.77]	.979 [24.87]	.638 [16.21]	1.198 [30.43]

DIM J	DIM H	DIM E	DIM D	DIM C	DIM B	DIM A	INSERT ARRANGEMENT	NO OF POS	SHELL SIZE	MILITARY P/N ON CONNECTOR	TYCO P/N MARKED ON CONNECTOR	TYCO PART NO.
.544 [13.82]	2.188 [55.58]	.620 [15.75]	.428 [10.87]	2.411 [61.24]	2.069 [52.55]	2.650 [67.31]	MS18277-1	50	5	M24308/23-41Z	1757842-5	1-1757842-0
.524 [13.31]	2.168 [55.07]	.590 [14.99]	.418 [10.62]	2.401 [60.99]	2.059 [52.30]	2.620 [66.55]	MS18276-1	37	4	M24308/23-40Z	1757842-4	1757842-9
.432 [10.97]	2.282 [57.96]	.509 [12.93]	.316 [8.03]	2.505 [63.63]	2.164 [54.97]	2.744 [69.70]	MS18275-1	25	3	M24308/23-39Z	1757842-3	1757842-8
.412 [10.46]	2.262 [57.45]	.479 [12.17]	.306 [7.77]	2.495 [63.37]	2.154 [54.71]	2.714 [68.94]	MS18274-1	15	2	M24308/23-38Z	1757842-2	1757842-7
.432 [10.97]	1.635 [41.53]	.509 [12.93]	.316 [8.03]	1.857 [47.17]	1.516 [38.51]	2.103 [53.42]	MS18273-1	9	1	M24308/23-37Z	1757842-1	1757842-6
.412 [10.46]	1.615 [41.02]	.479 [12.17]	.306 [7.77]	1.847 [46.91]	1.506 [38.25]	2.073 [52.65]	MS18277-1	50	5	M24308/23-41Z	1757842-5	1757842-5
.432 [10.97]	2.282 [57.96]	.509 [12.93]	.316 [8.03]	2.505 [63.63]	2.164 [54.97]	2.744 [69.70]	MS18276-1	37	4	M24308/23-40Z	1757842-4	1757842-4
.412 [10.46]	2.262 [57.45]	.479 [12.17]	.306 [7.77]	2.495 [63.37]	2.154 [54.71]	2.714 [68.94]	MS18275-1	25	3	M24308/23-39Z	1757842-3	1757842-3
.432 [10.97]	1.635 [41.53]	.509 [12.93]	.316 [8.03]	1.857 [47.17]	1.516 [38.51]	2.103 [53.42]	MS18274-1	15	2	M24308/23-38Z	1757842-2	1757842-2
.412 [10.46]	1.615 [41.02]	.479 [12.17]	.306 [7.77]	1.847 [46.91]	1.506 [38.25]	2.073 [52.65]	MS18273-1	9	1	M24308/23-37Z	1757842-1	1757842-1

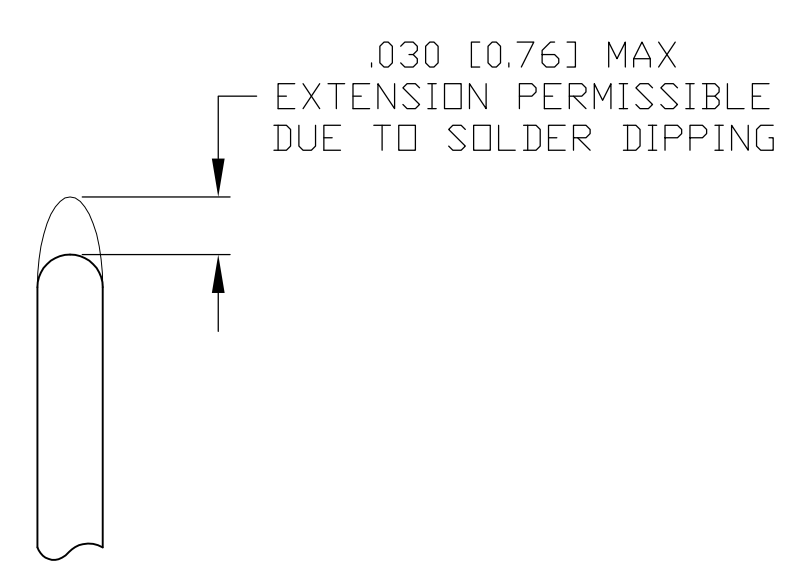

DETAIL K
SCALE 10:1
FOR 1757842-6 THRU -10 ONLY

THIS DRAWING IS A CONTROLLED DOCUMENT.

APPROVED: D. MILLER, DATE: 3-27-06

DESIGNED: C.C. THOMAS, DATE: 3-22-06

DATE: 3-27-06

TE Connectivity

RECEPTACLE ASSEMBLY, AMPLIMITE, RT ANGLE, SERIES 109, SIZE 1 THRU 5

SIZE: A1, CASE CODE: 00779, DRAWING NO: 1757842

SCALE: 4:1, SHEET: 1 OF 2, REV: A

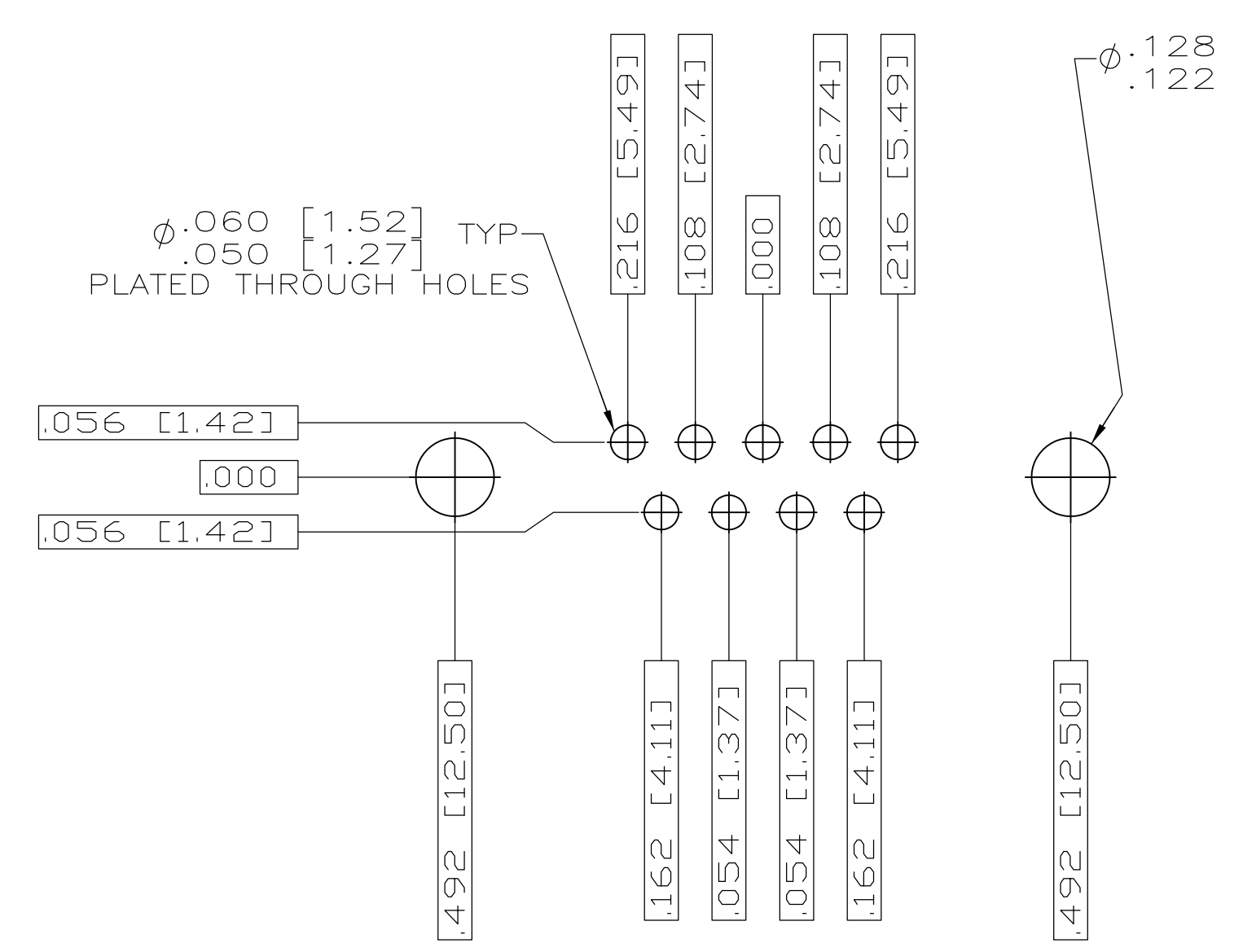

RECOMMENDED P.C. BOARD LAYOUT
SHELL SIZE 1 (9 POSITION) ⚠

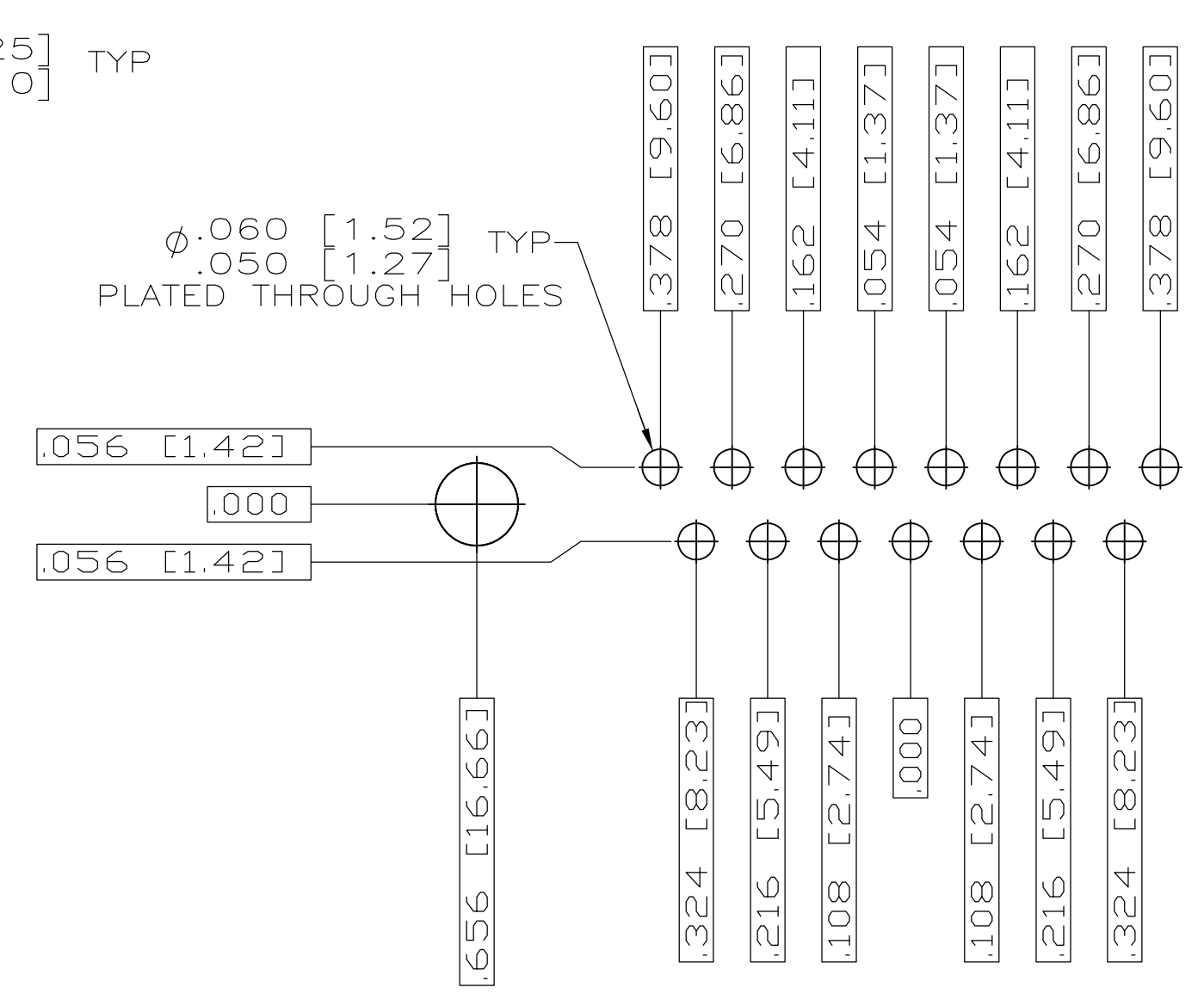

RECOMMENDED P.C. BOARD LAYOUT
SHELL SIZE 2 (15 POSITION) ⚠

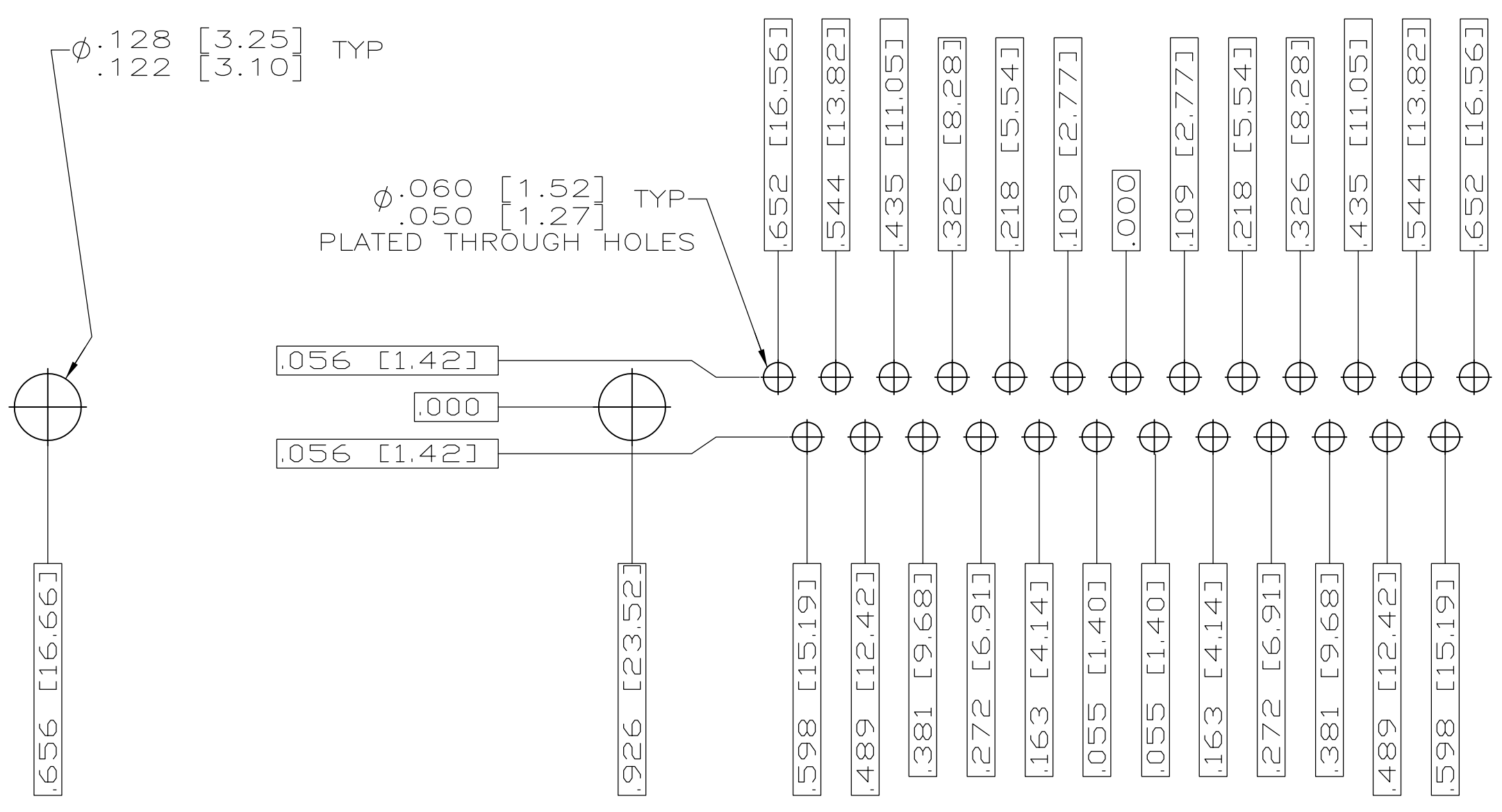

RECOMMENDED P.C. BOARD LAYOUT
SHELL SIZE 3 (25 POSITION) ⚠

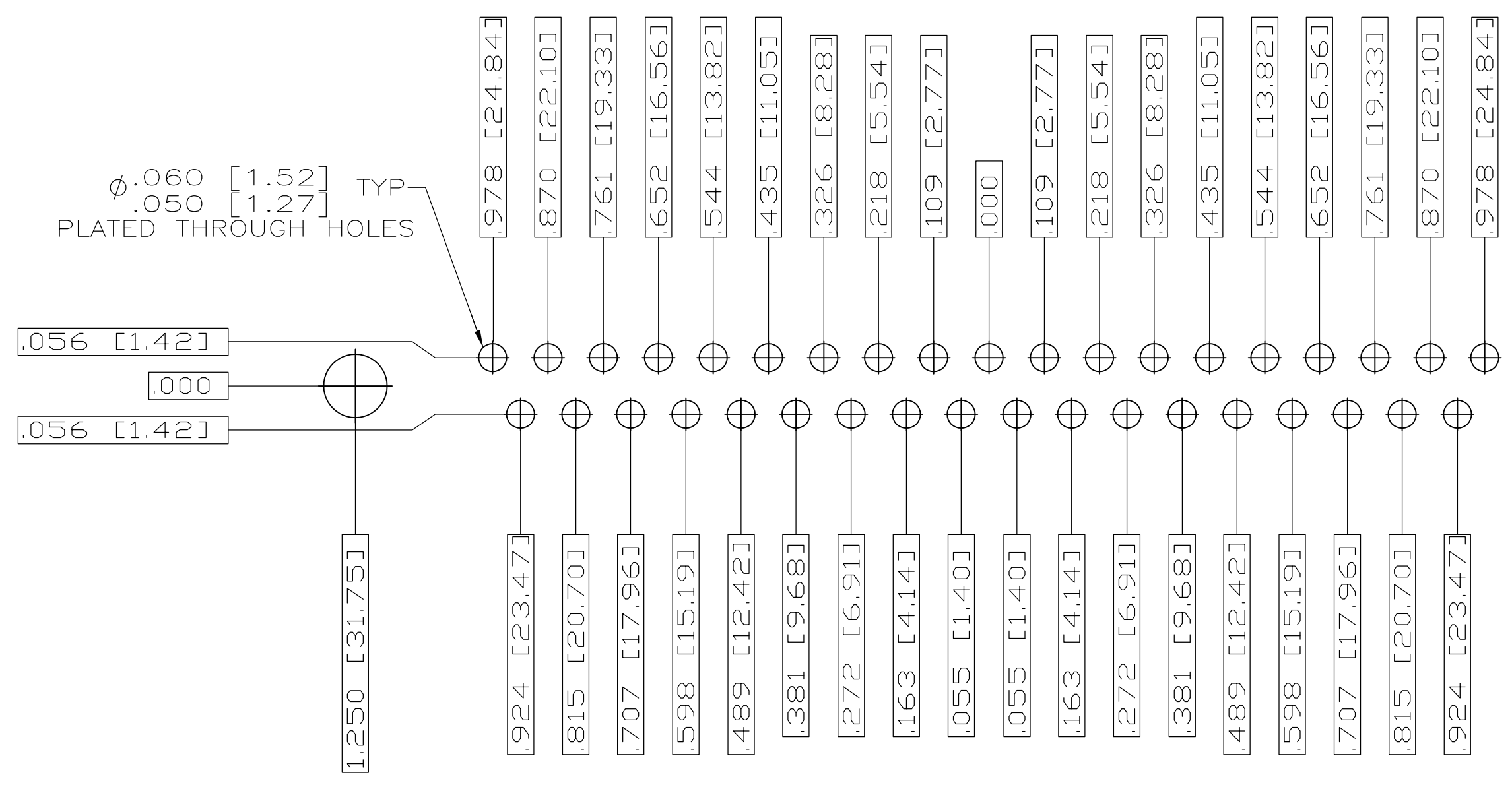

RECOMMENDED P.C. BOARD LAYOUT
SHELL SIZE 4 (37 POSITION) ⚠

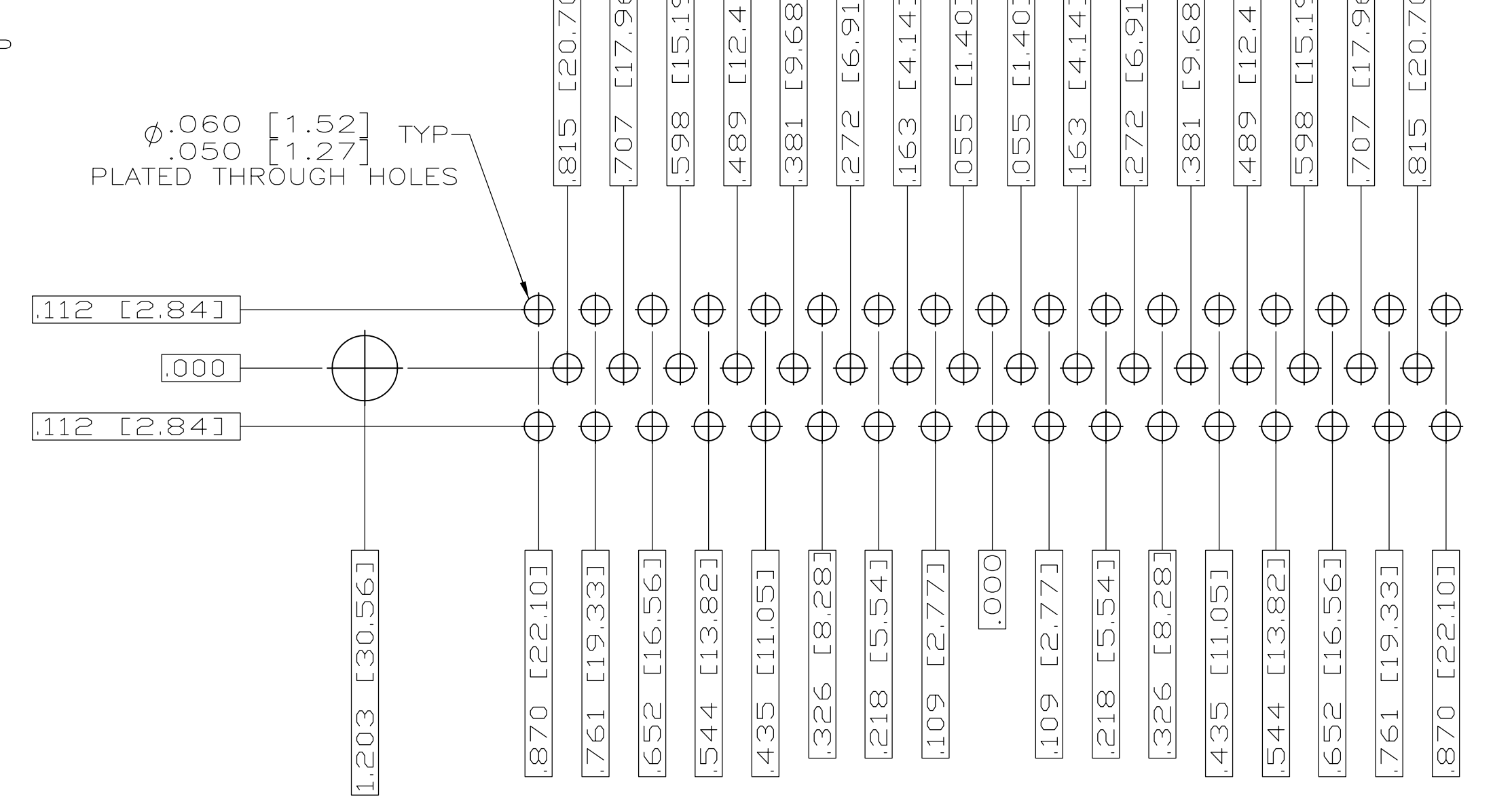

RECOMMENDED P.C. BOARD LAYOUT
SHELL SIZE 5 (50 POSITION) ⚠

THIS DRAWING IS A CONTROLLED DOCUMENT.		DN C.C.THOMAS 3-22-06	 TE Connectivity															
DIMENSIONS: INCHES		CHK D.HOFFMAN 3-27-06																
TOLERANCES UNLESS OTHERWISE SPECIFIED:		APVD D.MILLER 3-27-06	NAME															
<table border="1"> <tr><td>0</td><td>PLC</td><td>± .010</td></tr> <tr><td>1</td><td>PLC</td><td>± .005</td></tr> <tr><td>2</td><td>PLC</td><td>± .002</td></tr> <tr><td>3</td><td>PLC</td><td>± .001</td></tr> <tr><td>4</td><td>PLC</td><td>± .0005</td></tr> </table>		0	PLC	± .010	1	PLC	± .005	2	PLC	± .002	3	PLC	± .001	4	PLC	± .0005	PRODUCT SPEC	RECEPTACLE ASSEMBLY,AMPLITE RIGHT ANGLE,SERIES 109,SIZE 1 THRU 5
0	PLC	± .010																
1	PLC	± .005																
2	PLC	± .002																
3	PLC	± .001																
4	PLC	± .0005																
MATERIAL SEE CALLOUTS		FINISH SEE CALLOUTS	APPLICATION SPEC															
WEIGHT		SIZE A1	RESTRICTED TO															
CUSTOMER DRAWING		CAGE CODE 00779	DRAWING NO 1757842															
SCALE 4:1		SHEET 2	REV A															

单击下面可查看定价，库存，交付和生命周期等信息

[>>TE Connectivity\(泰科\)](#)