

THIS DRAWING IS UNPUBLISHED. RELEASED FOR PUBLICATION  
 © COPYRIGHT - By - ALL RIGHTS RESERVED.

LOC	DIST	REVISIONS			
P	LTR	DESCRIPTION	DATE	DWN	APVD
AF	50	E2	REVISED PER ECR-19-005868	16MAY2019	BDA SV

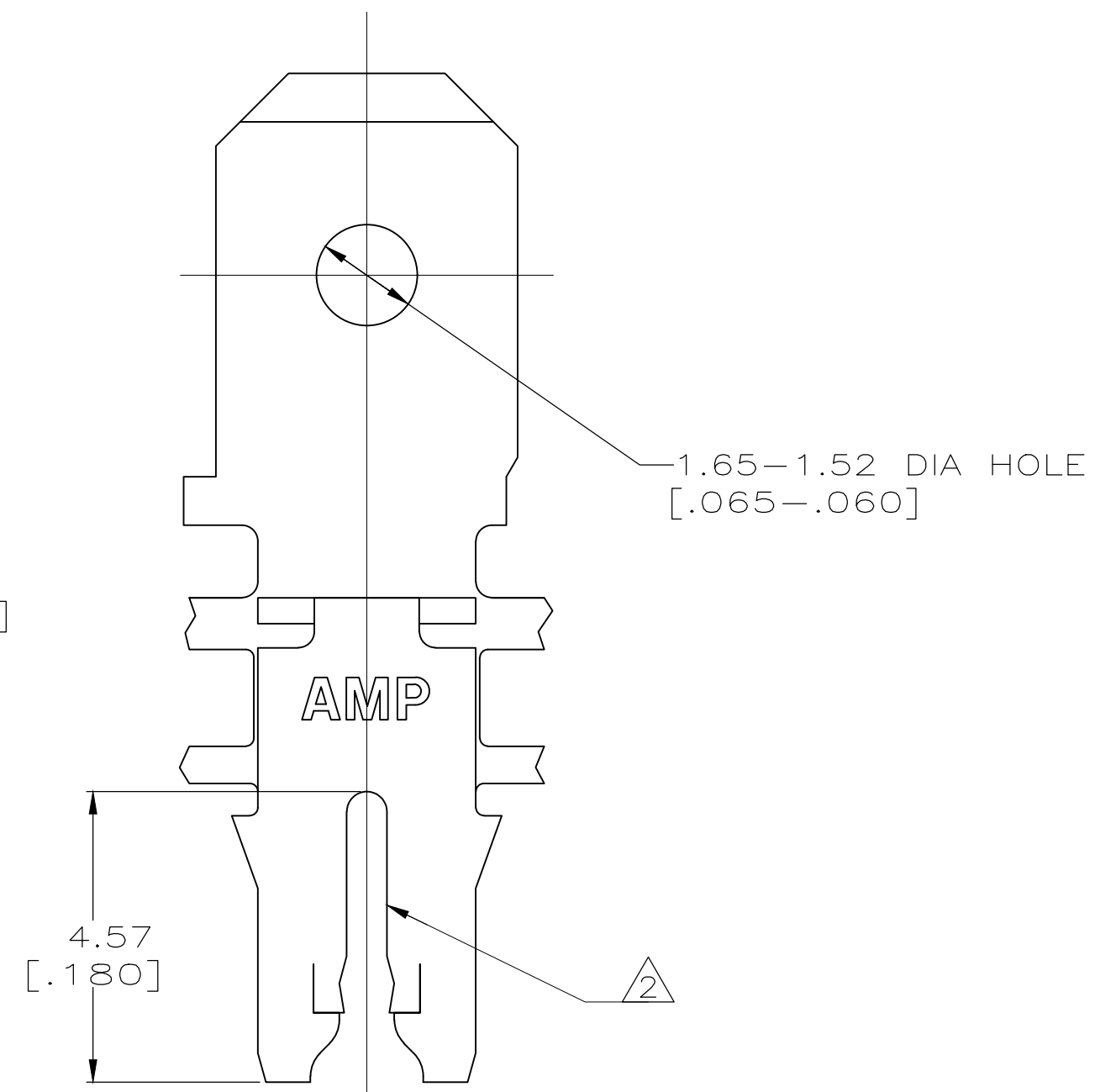
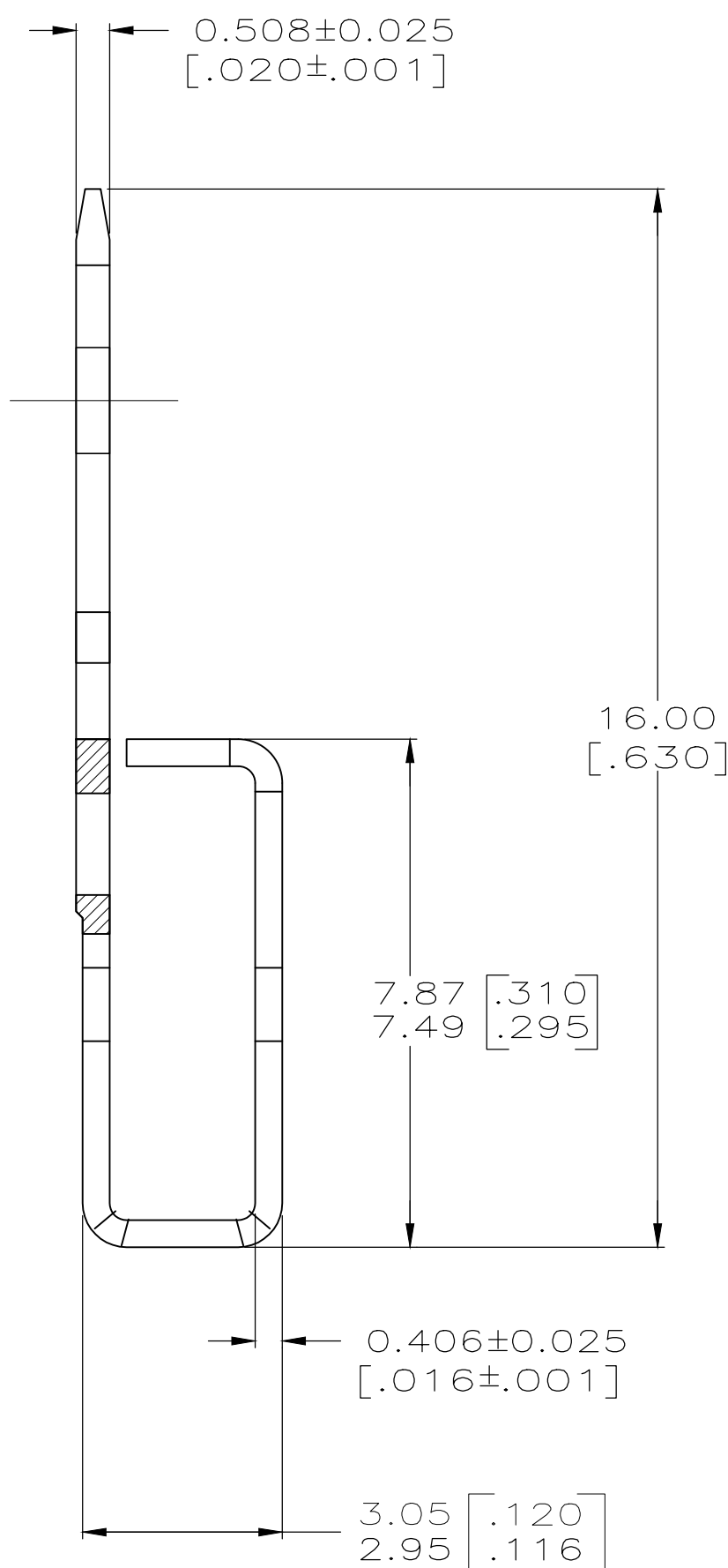
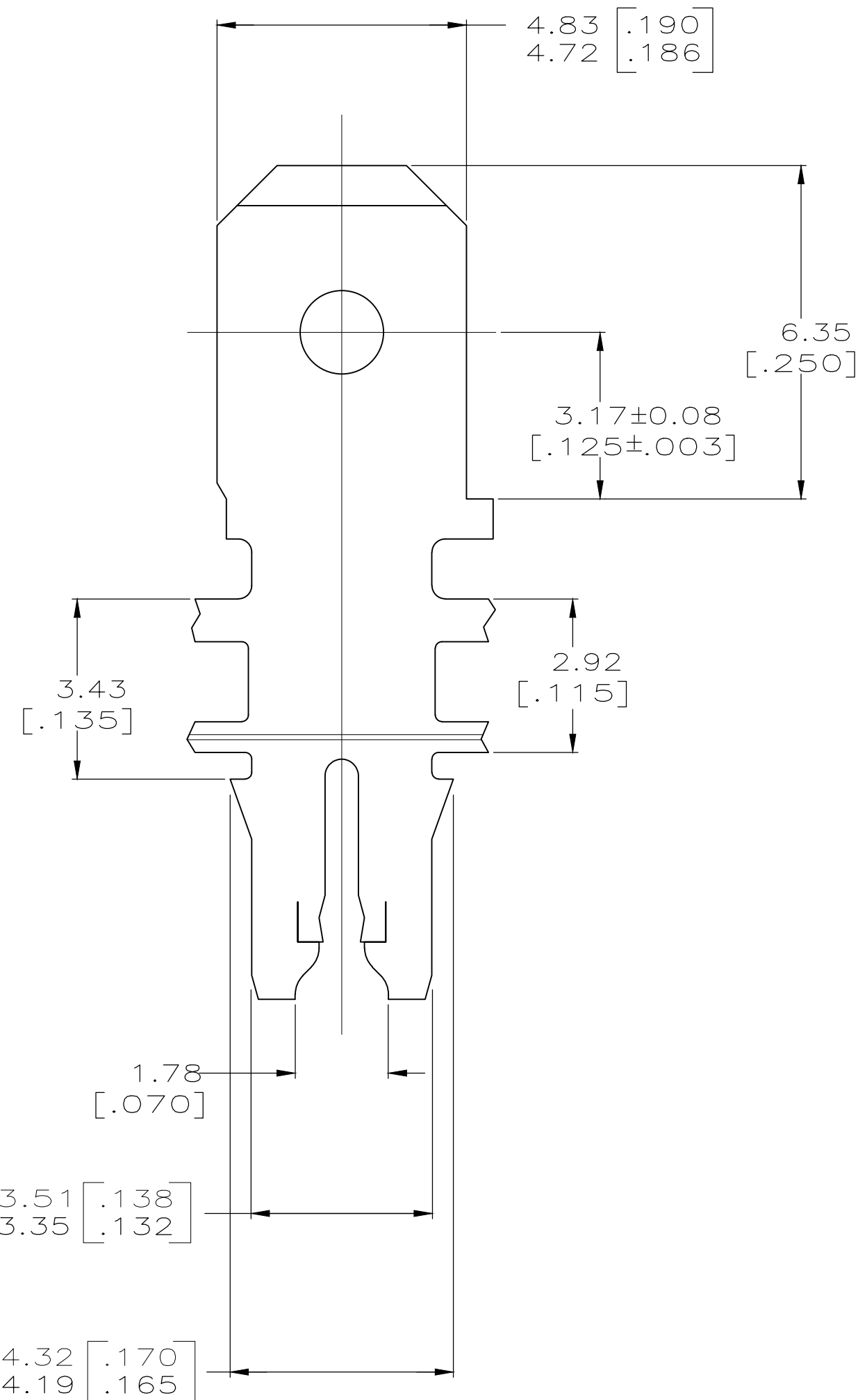
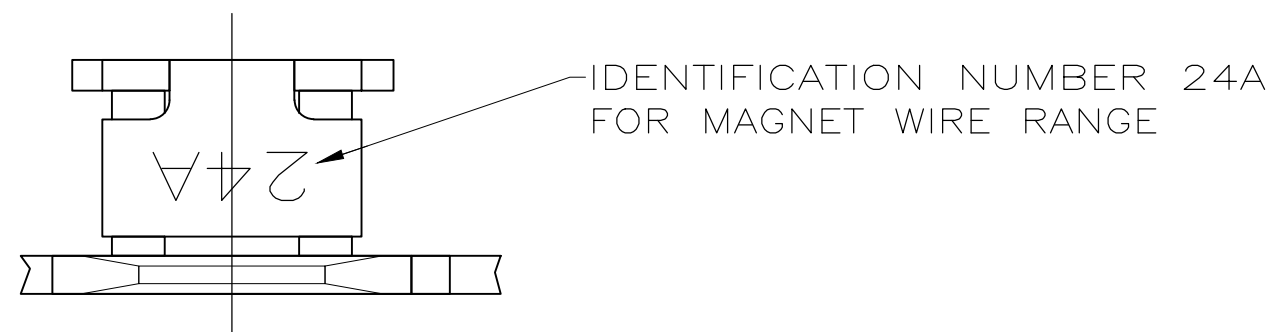

- 1 CONTINUOUS STRIP ON REELS WITH TERMINALS LOCATED ON 5.59±0.08 [.220±.003] CENTERS
- 2 SLOT TERMINATES A SINGLE MAGNET WIRE ONLY. ALUMINUM RANGE: 0.97-1.22mm [#18.5-#16.5] AWG.
- 3 AFTER INSERTION INTO PLASTIC HOLDER TAB PORTION MUST BE BENT OVER 45° TO 90° OR POTTED-IN TO PREVENT PULL-OUT WHEN MATING RECEPTACLE IS DISCONNECTED.
- 4 ANVIL HEIGHT TO BE 2.29±0.13 [.090±.005]
- 5 VARNISH RESIST OVER TIN PLATE

5	REVERSE	TIN PLATE	63668-3
	STANDARD	TIN PLATE	63668-2
5	STANDARD	TIN PLATE	63668-1
	REELING	FINISH	PART NO

THIS DRAWING IS A CONTROLLED DOCUMENT.		DWN MICHAEL S. FEHER 9/3/92	<b>TE</b> TE Connectivity		
DIMENSIONS: MM [ INCHES ]		CHK JEFF R. RUTH 9/4/92			
TOLERANCES UNLESS OTHERWISE SPECIFIED:		APVD TERRY SHUTTER 9/4/92	NAME TERMINAL, TAB, 4.75 [.187] FASTON, MAG-MATE		
0 PLC ± - 1 PLC ± - 2 PLC ± 0.25 [.010] 3 PLC ± - 4 PLC ± - ANGLES ± -		PRODUCT SPEC 108-2012	SIZE A2	CAGE CODE 00779	DRAWING NO C-63668
MATERIAL BRASS	FINISH SEE TABLE	APPLICATION SPEC 114-2046	WEIGHT -	SCALE 10:1	SHEET 1 OF 1
CUSTOMER DRAWING			REV E2	RESTRICTED TO -	

单击下面可查看定价，库存，交付和生命周期等信息

[>>TE Connectivity\(泰科\)](#)