

4

3

2

1

THIS DRAWING IS UNPUBLISHED. RELEASED FOR PUBLICATION, 1989.
 © COPYRIGHT 1989 BY AMP INCORPORATED. ALL RIGHTS RESERVED.

LOC		DIST		REVISIONS			DATE	DWN	APVD
P	LTR	DESCRIPTION							
AI	-								
87-9182		B	Zeichnung in CAD neu erstellt; Gehäuse PN 207001 durch PN 182917 ersetzt			10.09.97	Eberwein	-	

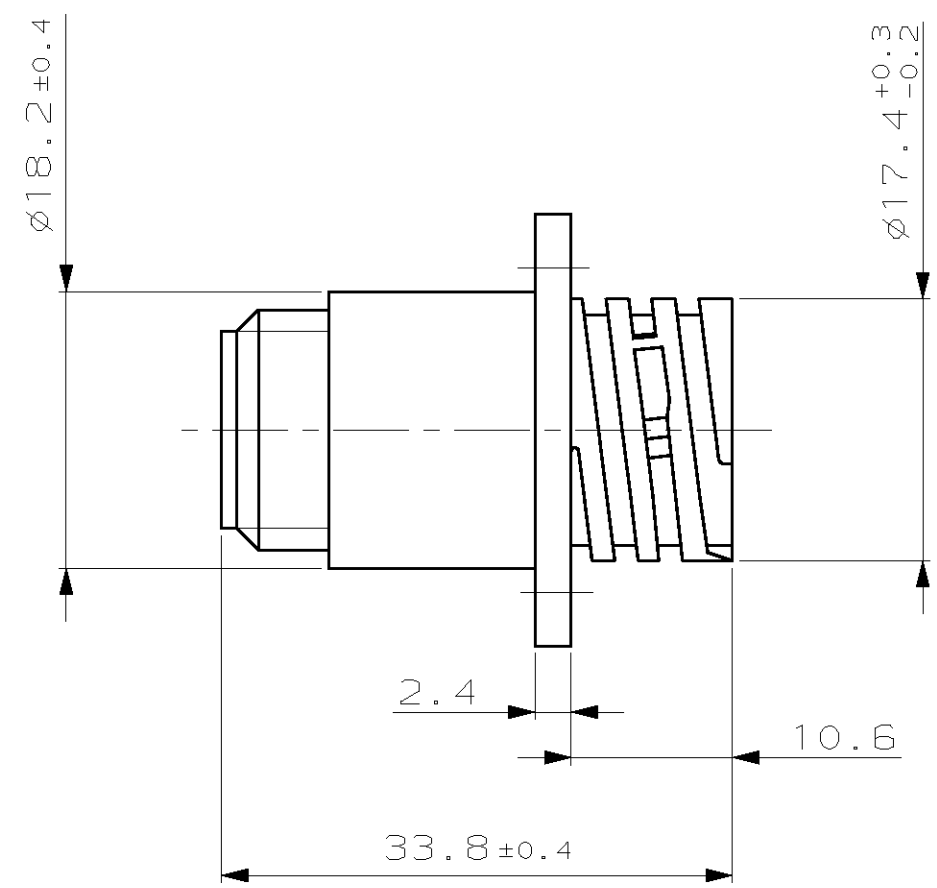
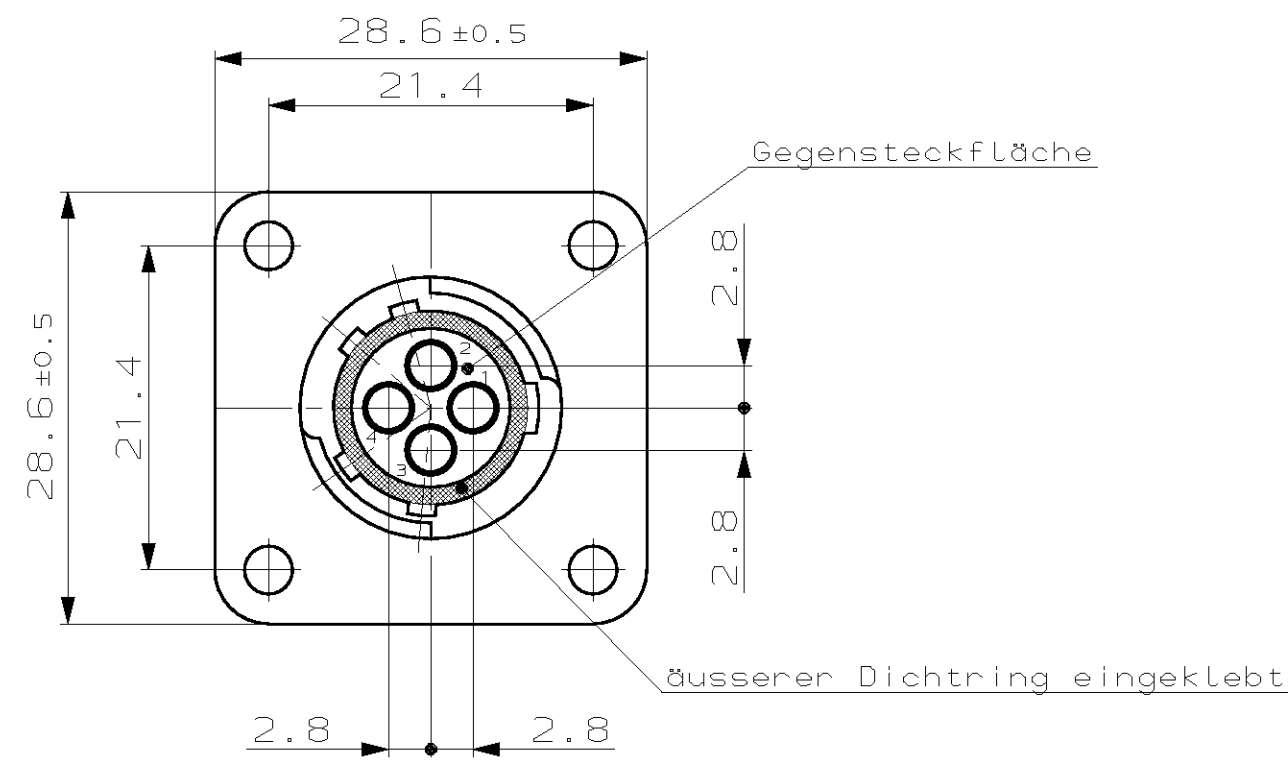

- BEMERKUNGEN:
1. Kammern beidseitig beschriftet
 2. zur Aufnahme von Type III + Kontakten

AMP PART NO	REV.	PCS.	MATERIAL	SURFACE COLOR	DESCRIPTION	ITEM NO
-	-	-	-	-	-	-
963304-1	B	-	PBT	schwarz	Stiftgehäuse mit Flansch	-
		-	NBR	schwarz	Äusserer Dichtungsring	-

THIS DRAWING IS A CONTROLLED DOCUMENT FOR AMP INCORPORATED. IT IS SUBJECT TO CHANGE AND THE CONTROLLING ENGINEERING ORGANIZATION SHOULD BE CONTACTED FOR THE LATEST REVISION.		DWN N. Buenger 18.01.89	AMP Deutschland GmbH D - 63225 Langen	
DIMENSIONS: mm		CHK Adamski 18.01.89	AMP	
TOLERANCES UNLESS OTHERWISE SPECIFIED, ALL GEMEINTOLERANZEN n. ISO 8015		APVD -	Stiftgehäuse mit Flansch	
0 PLC ± 1 PLC ±0,2 mm 2 PLC ± 3 PLC ±		PRODUCT SPEC -	CPC, Grösse 11-4	
ANGLES /WINKEL ±2°		APPLICATION SPEC -	SIZE A3	CAGE CODE 00779
FINISH schwarz		WEIGHT -	DRAWING NO C-963304	RESTRICTED TO -
CUSTOMER DRAWING			2:1	1 OF 1 REV B

单击下面可查看定价，库存，交付和生命周期等信息

[>>TE Connectivity\(泰科\)](#)