

THIS DRAWING IS UNPUBLISHED. RELEASED FOR PUBLICATION AUG. 2006.
 COPYRIGHT BY TYCO ELECTRONICS CORPORATION. ALL RIGHTS RESERVED.

LOC	DIST	REVISIONS					
DW	—	P	LTR	DESCRIPTION	DATE	DWN	APVD
		A2		REVISED. (ECR-14-009374)	02OCT14	SW	SC

NOTE:

- 1. MATERIAL:
 HOUSING: THERMOPLASTIC (LCP) WITH 30% GF, UL 94V-0, BLACK COLOR.
 CAP: NYLON 9T WITH 33% GF, UL 94V-0, BLACK COLOR.
 CONTACTS: PHOSPHOR BRONZE.
 PEGS: BRASS.
- 2. FINISH:
 CONTACTS: 0.127 μm[5 μ"]MIN. GOLD PLATED OVER
 1.27 μm[50 μ"]MIN. NICKEL ON ENTIRE CONTACT.
 PEGS: 2.54 μm[100 μ"]MIN. MATTE-TIN PLATED.
- 3. REFLOW SOLDER CAPABLE TO 260°C AS PER TYCO SPEC. 109-201, CONDITION B.
- 4. NO TYCO LOGO AND DATE CODE ON THE PRODUCT.
- 5. RECEPTACLE PART NUMBERS (BASE NO.#): 1775187 THRU 1775190.

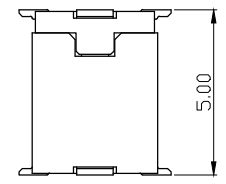
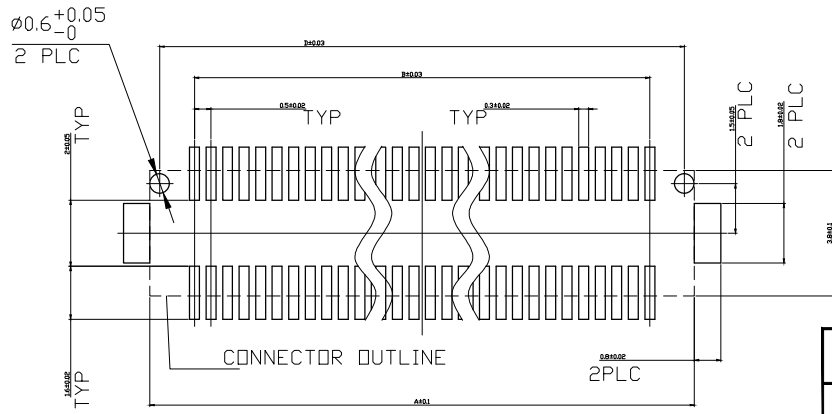
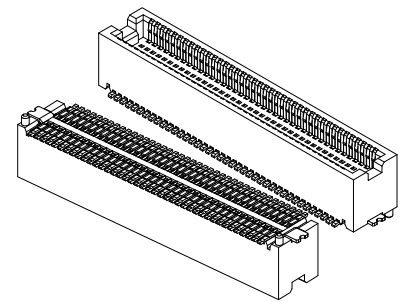
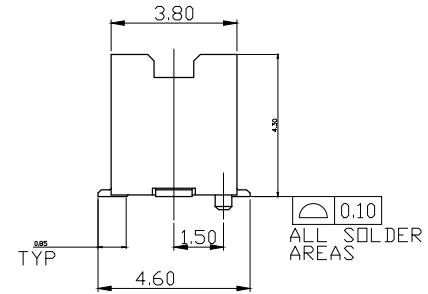
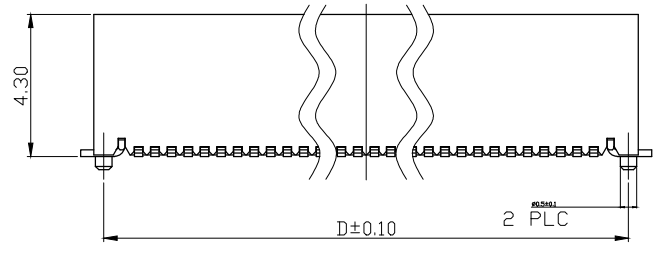
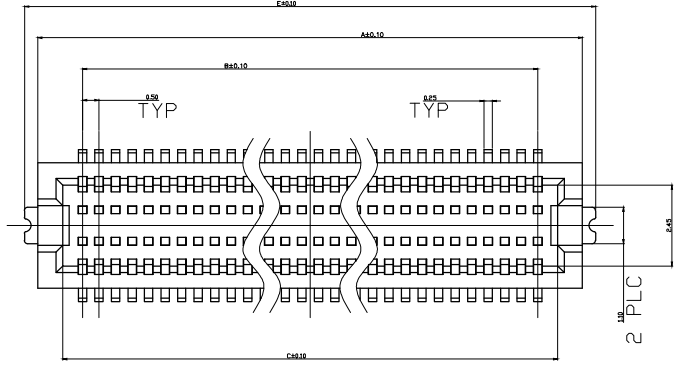

STACKING HEIGHT

EOL	WITHOUT	WEIGHT						NO. OF CONTACTS	PART NUMBER
		E	D	C	B	A	2		
		0.715g	18.00	16.60	15.70	14.50	17.20	60	6-1775184-0
		0.597g	15.50	14.10	13.20	12.00	14.70	50	5-1775184-0
		0.48g	13.00	11.60	10.70	9.50	12.20	40	4-1775184-0
		0.363g	10.50	9.10	8.20	7.00	9.70	30	3-1775184-0
		0.245g	8.00	6.60	5.70	4.50	7.20	20	2-1775184-0

THIS DRAWING IS A CONTROLLED DOCUMENT.

DWN H. HUANG 31AUG2007
 CHK S. HOU 31AUG2007
 APVD W.J. KE 31AUG2007

PRODUCT SPEC
 108-57578
 QUALIFICATION TEST REPORT
 501-57669

NAME
 BOARD TO BOARD CONNECTOR,
 0.5 MM PITCH, FINE-MATE, PLUG,
 5H, WITH BOSSES & PEG & CAP

SIZE A3 CAGE CODE 00779 DRAWING NO. C-1775184 RESTRICTED TO —

WEIGHT SEE TABLE
 CUSTOMER DRAWING SCALE — SHEET 1 OF 3 REV A2

DIMENSIONS: MM	TOLERANCES UNLESS OTHERWISE SPECIFIED:
2 PLC	0 PLC ± 0.5 1 PLC ± 0.38 2 PLC ± 0.25 3 PLC ± 0.15 4 PLC ANGLES ± 5°

MATERIAL SEE NOTE FINISH SEE NOTE

TE Connectivity

4

3

2

1

THIS DRAWING IS UNPUBLISHED. RELEASED FOR PUBLICATION
 COPYRIGHT BY TYCO ELECTRONICS CORPORATION. ALL RIGHTS RESERVED.

LOC	DIST	REVISIONS			
P	LTR	DESCRIPTION	DATE	DWN	APVD
DW	—	SEE SHEET 1			

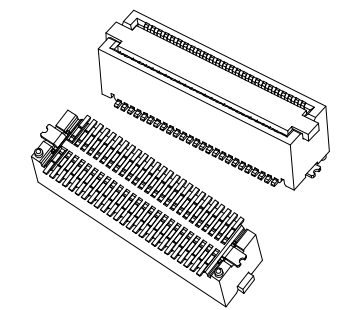
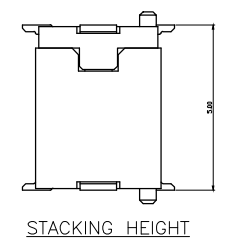
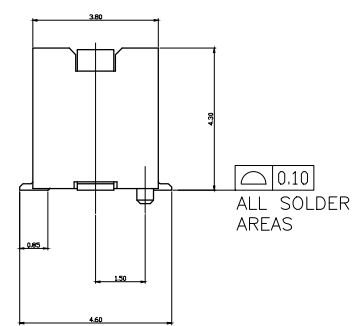
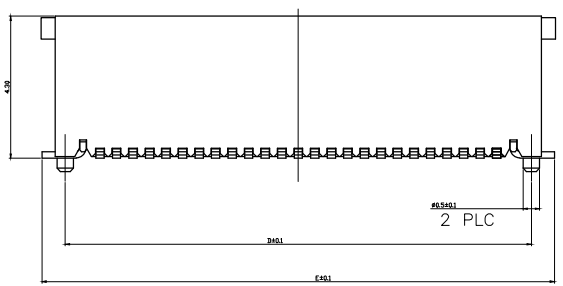
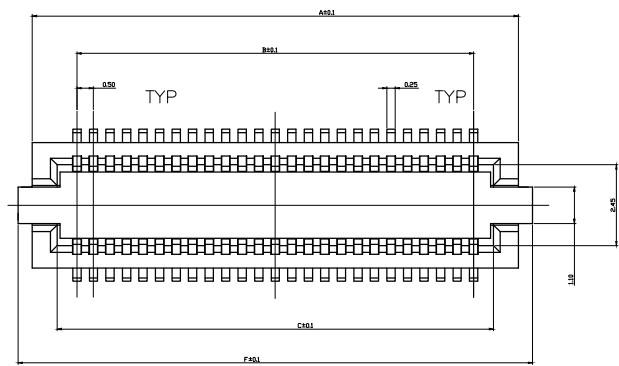

WITH	0.6g	15.56	15.50	14.10	13.20	12.00	14.70	50	5-1775184-1					
CAP FOR PICK/PLACE	WEIGHT	DIMENSIONS					F	E	D	C	B	A	NO. OF CONTACTS	PART NUMBER

THIS DRAWING IS A CONTROLLED DOCUMENT.		DWN H. HUANG 31AUG2007	TE Connectivity			
DIMENSIONS: MM		CHK S. HOU 31AUG2007				
TOLERANCES UNLESS OTHERWISE SPECIFIED:		APVD W.J. KE 31AUG2007	NAME BOARD TO BOARD CONNECTOR, 0.5 MM PITCH, FINE-MATE, PLUG, 5H, WITH BOSSES & PEG & CAP			
0 PLC ± 0.50 1 PLC ± 0.38 2 PLC ± 0.25 3 PLC ± 0.15 4. PLC ANGLES ± 5°		PRODUCT SPEC —	SIZE A3	CAGE CODE 00779	DRAWING NO C-1775184	RESTRICTED TO —
MATERIAL SEE NOTE	FINISH SEE NOTE	WEIGHT SEE TABLE	SCALE —		SHEET 2 OF 3	REV A2
		CUSTOMER DRAWING				

THIS DRAWING IS UNPUBLISHED. RELEASED FOR PUBLICATION AUG, 2006.
 © COPYRIGHT BY TYCO ELECTRONICS CORPORATION. ALL RIGHTS RESERVED.

LOC	DIST	REVISIONS			
P	LTR	DESCRIPTION	DATE	DWN	APVD
DW	—	SEE SHEET 1			

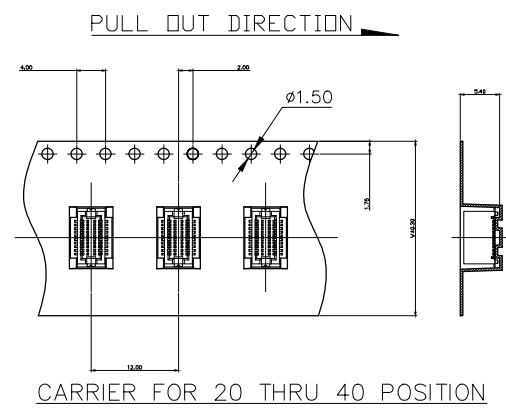
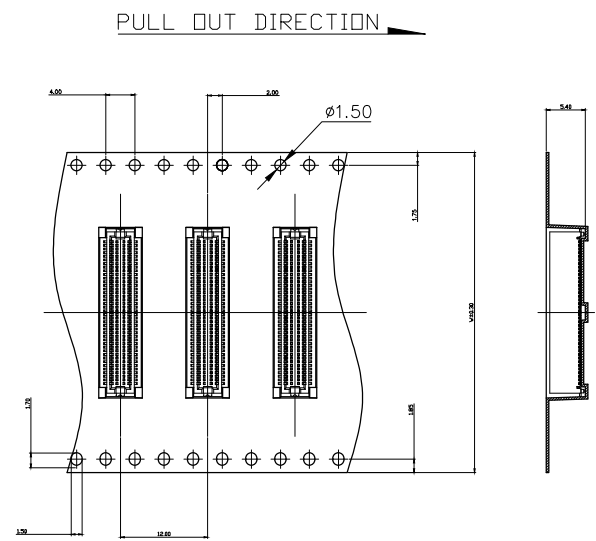
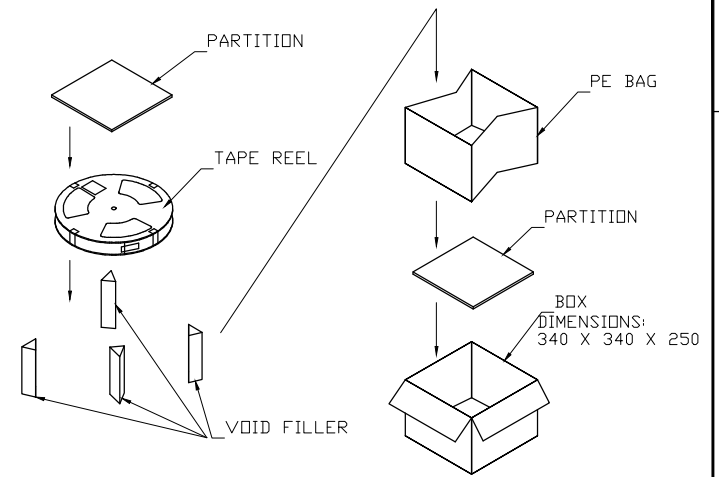
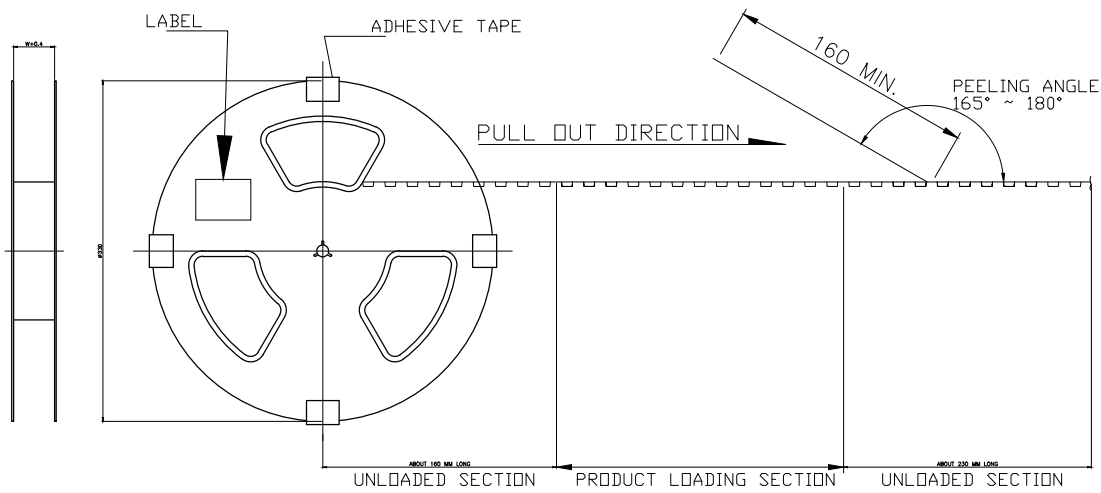

1000	6	6000	32	8.29	4.29	60
				7.59	3.58	50
1000	7	7000	24	7.74	3.36	40
				6.91	2.54	30
				6.09	1.71	20
PCS/REEL	REELS/BOX	QUANTITY	DIM W	G/W (KG)	N/W (KG)	NO. OF POS.

THIS DRAWING IS A CONTROLLED DOCUMENT.		DWN H. HUANG	31AUG2007	TE Connectivity BOARD TO BOARD CONNECTOR, 0.5 MM PITCH, FINE-MATE, PLUG, 5H, WITH BOSSES & PEG & CAP		
DIMENSIONS: MM		CHK S. HOU	31AUG2007			
TOLERANCES UNLESS OTHERWISE SPECIFIED:		APVD W.J. KE	31AUG2007	NAME		
2 PLC	0 PLC ± -	PRODUCT SPEC		DRAWING NO		
	1 PLC ± -	QUALIFICATION TEST REPORT		SIZE	CAGE CODE	RESTRICTED TO
	2 PLC ± -	WEIGHT		A3	00779	
	3 PLC ± -	CUSTOMER DRAWING		DRAWING NO C=1775184		
	4 PLC ± -			SCALE	SHEET	REV
	ANGLES ± -			—	3 OF 3	A2
MATERIAL SEE NOTE	FINISH SEE NOTE					

单击下面可查看定价，库存，交付和生命周期等信息

[>>TE Connectivity\(泰科\)](#)