

REVISIONS			
REV	DESCRIPTION	DATE	APPROVED
03 <sub>3</sub>	REVISED	10/18/80	[Signature]

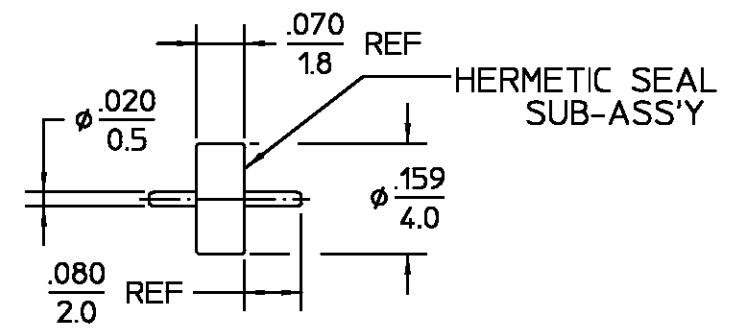
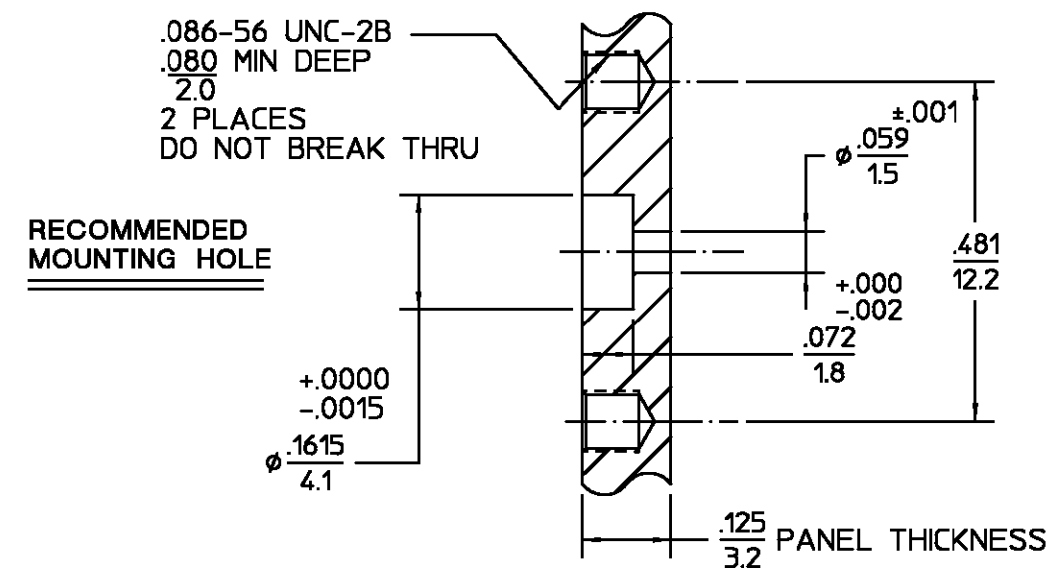

COMPONENT	MATERIAL	FINISH
HOUSING	STAINLESS STEEL PER ASTM-A484 AND ASTM-A582, TYPE 303	GOLD PLATE PER MIL-G-45204
DIELECTRIC	TFE FLUOROCARBON PER ASTM-D-1457	N/A
CENTER CONTACT	BERYLLIUM COPPER PER ASTM-B-196 OR ASTM-B-197, ALLOY C17300, CONDITION H	GOLD PLATE PER MIL-G-45204
CONTACT EXT BUSHING	IRON-NICKEL-COBALT ALLOY PER MIL-I-23011 CLASS 1 (KOVAR)	GOLD PLATE PER MIL-G-45204
HERMETIC SEAL	GLASS BEAD	N/A

UNLESS OTHERWISE SPECIFIED DIMENSIONS ARE IN INCHES TOLERANCE ON FRAC. DEC. ANGLES ± 1/64 ±.005 ± 1°	DRAWN BY SB	DATE 10/29/80	AMP Incorporated 140 Fourth Avenue Waltham, MA 02451-7599
	CHECKED BY KD	11/6/80	
	APPD BY TS	11/6/80	
These drawings and specifications are the property of M/A-COM Incorporated and shall not be reproduced or copied or used in whole or in part as the basis for the manufacture or sale of item(s) without written permission.	USE ASS'Y PROCEDURE	TITLE OSM 2-HOLE FLANGE MOUNT JACK RECEPTACLE WITH HERMETIC SUBASSY	
	NO. AP. 20-606	SIZE B	CODE IDENT NO. 26805
	408-04850	SCALE 4:1	2052-0435-00
			REV 03 <sub>3</sub>
			SHEET 1 OF 1

NOTES:  
1. CAPTURED CENTER CONTACT

.XXX = in  
XX.X = mm (REF)

CUSTOMER DRAWING

AMP PART # 1052455-1  
SHEET 1 OF 1 REV A

单击下面可查看定价，库存，交付和生命周期等信息

[>>TE Connectivity\(泰科\)](#)