

REVISIONS					
P	LTR	DESCRIPTION	DATE	DWN	APVD
D		REVISED PER ECO-21-001024	26JUL21	JY	SH

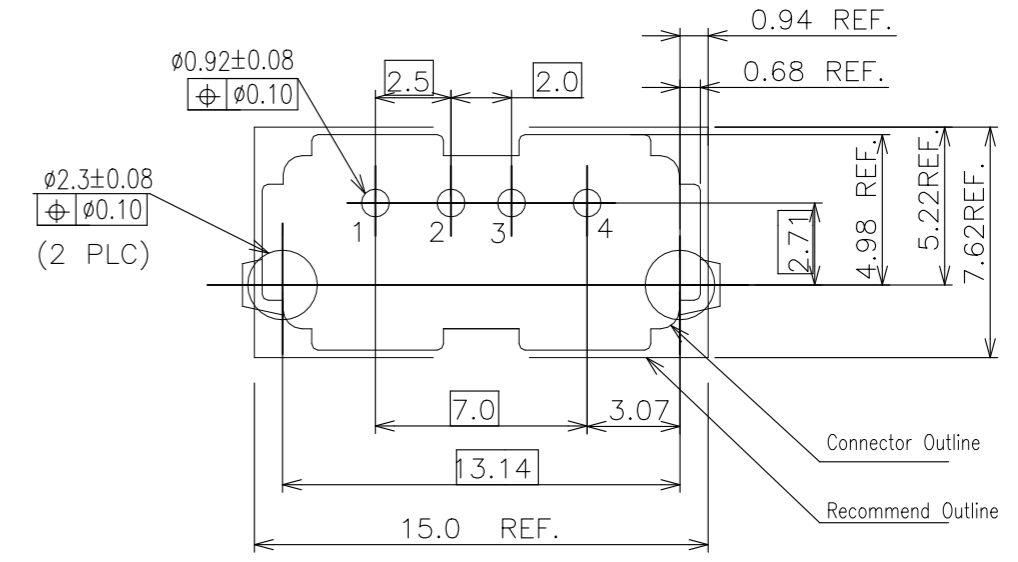

RECOMMENDED P.C. BOARD LAYOUT (T=1.6)

- NOTE:
- MATERIAL:
 - HOUSING: PBT (SOLDER CAPABLE, UL 94-V0, COLOR: SEE TABLE.)
 - HOUSING: PA9T (REFLOW CAPABLE, UL 94-V0, COLOR: SEE TABLE.)
 - CAP: LCP (REFLOW CAPABLE, UL 94-V0, COLOR: BLACK.)
 - BACK STOPPER: PBT (SOLDER CAPABLE, UL 94-V0, COLOR: BLACK.)
 - CONTACT: PHOSPHOR BRONZE, THICKNESS = 0.25mm.
 - SHIELD: STAINLESS STEEL, THICKNESS = 0.30mm.
 - FINISH:
 - CONTACT: GOLD FLASH OVER
 - 0.762um [30u"] MIN. PALLADIUM-NICKEL PLATED ON CONTACT
 - 2.54um [100u"] MIN. MATTE-TIN ON SOLDER TAILS.
 - 1.27um [50u"] MIN. NICKEL UNDERPLATED ALL OVER.
 - SHIELD: 2.54um [100u"] MIN. TIN PLATED OVER
 - 1.27um [50u"] MIN. NICKEL UNDERPLATED
 - SHIELD: 0.762-2.03um [30-80u"] SOLDERABLE NICKEL OVER 0.762-2.03um [30-80u"] COPPER

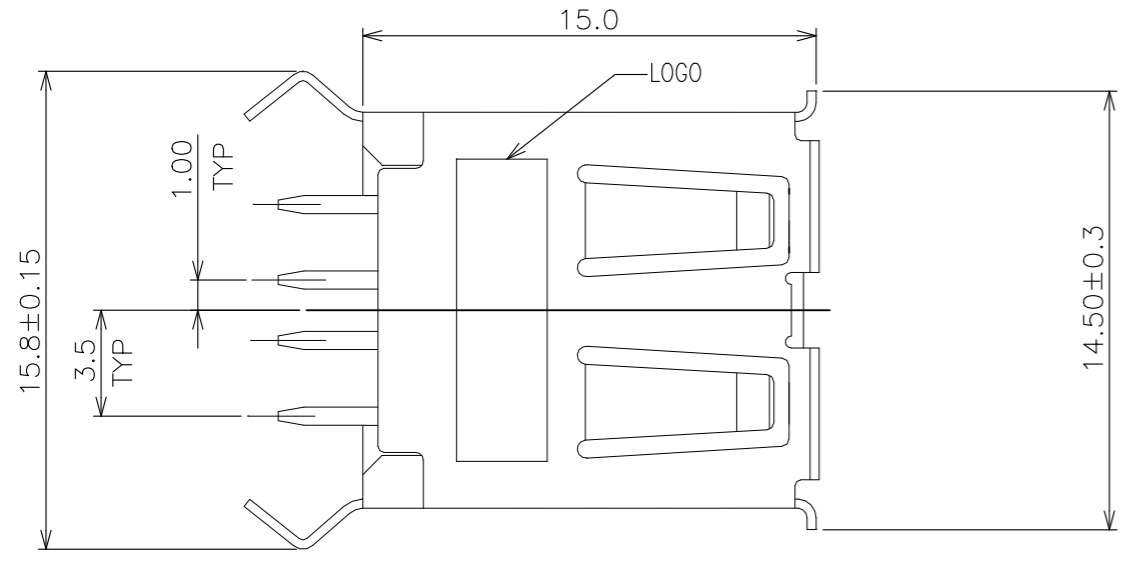
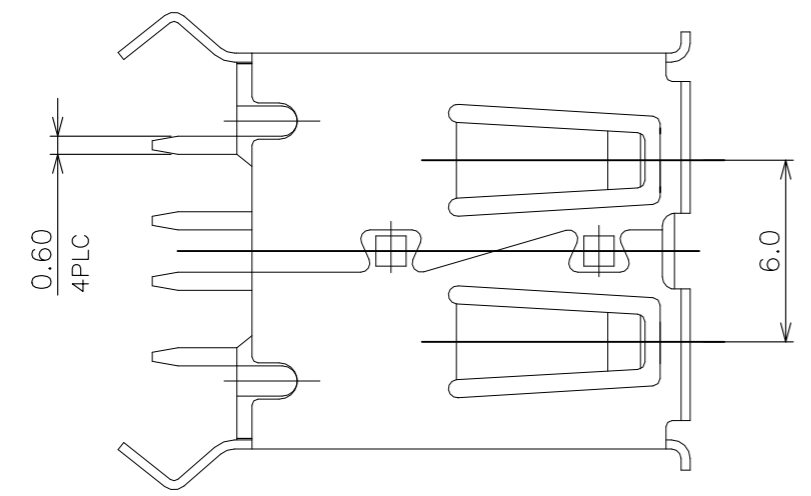
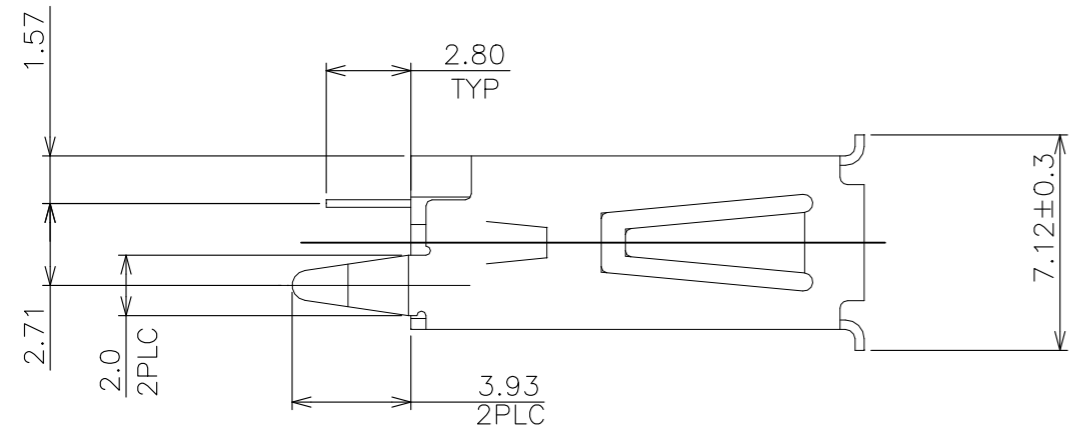
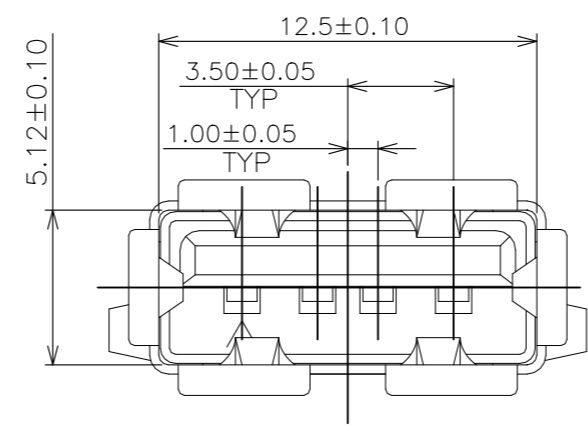

SEE SHEET 4	BLACK	1734366-5	△	△
SEE SHEET 5	BLACK	1734366-4	△	△
	BLUE	1734366-3		
SEE SHEET 4	WHITE	1734366-2	△	△
	BLACK	1734366-1		
PACKING	HSG'S COLOR	PART NUMBER	HOUSING MATERIAL	SHIELD FINISH

THIS DRAWING IS A CONTROLLED DOCUMENT.		DWN S. CHIEN 19SEP2008	TE Connectivity RECEIPT ASSY, VERTICAL, 4 POSITION THRU-HOLE, TYPE A USB		
DIMENSIONS: mm		CHK S. CHIEN 19SEP2008			
TOLERANCES UNLESS OTHERWISE SPECIFIED:		APVD W. KODAMA - NAME	PRODUCT SPEC 108-57547		
0 PLC ± 0.38 1 PLC ± 0.25 2 PLC ± 0.13 3 PLC ± 0.05 4 PLC ± - ANGLES ± 2°		PRODUCT SPEC 501-57635	SIZE	CAGE CODE	DRAWING NO
MATERIAL SEE NOTES		FINISH SEE NOTES	WEIGHT 1.82 GRAMS	A3 00779	C-1734366
		CUSTOMER DRAWING	SCALE 1:1	SHEET 1 OF 6	REV D

© 2021 TE Connectivity. All Rights Reserved.

REVISIONS					
P	LTR	DESCRIPTION	DATE	DWN	APVD
-	-	SEE SHEET 1	-	-	-

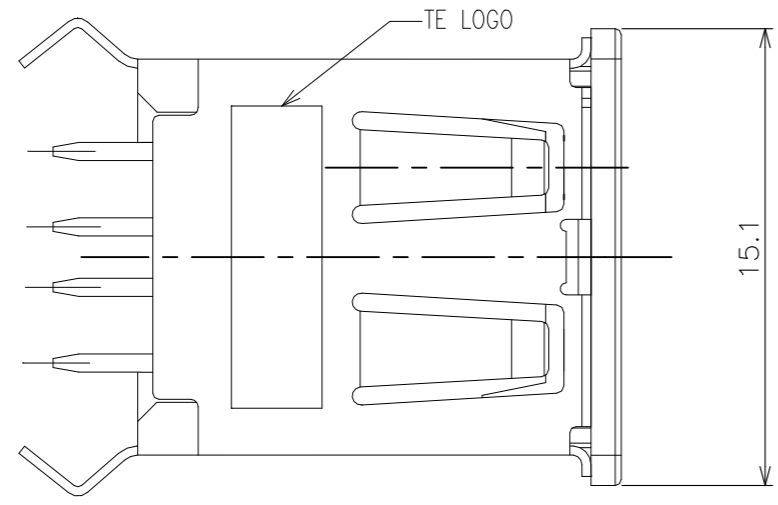

1734366-6 AS SHOW
OTHER DIMENSIONS ARE THE SAME AS SHEET1

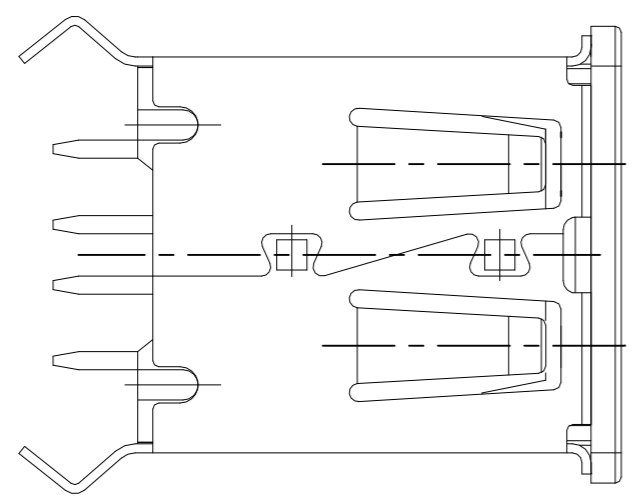
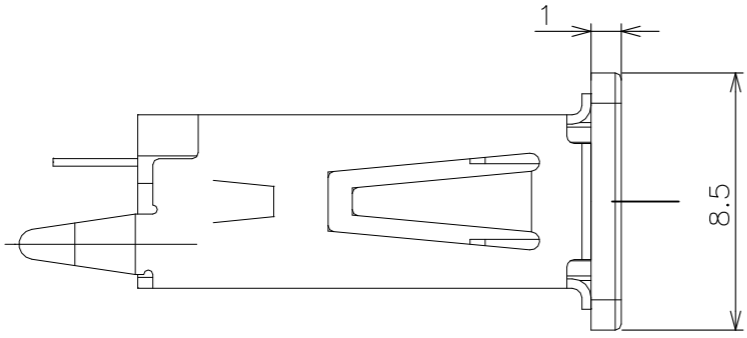

SEE SHEET 6	BLACK	1734366-6	△	△
PACKING	HSG'S COLOR	PART NUMBER	HOUSING MATERIAL	SHIELD FINISH

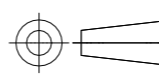
THIS DRAWING IS A CONTROLLED DOCUMENT.		DWN S. CHIEN 19SEP2008	 TE Connectivity		
		CHK S. CHIEN 19SEP2008			
DIMENSIONS: mm		APVD W.KODAMA	NAME		
		PRODUCT SPEC 108-57547	RECEPT ASSY,VERTICAL,4POSITION THRU-HOLE,TYPE A USB		
TOLERANCES UNLESS OTHERWISE SPECIFIED: 0 PLC ± 0.38 1 PLC ± 0.25 2 PLC ± 0.13 3 PLC ± 0.05 4 PLC ± - ANGLES ± 2°		APPLICATION SPEC 501-57635	SIZE	CAGE CODE	DRAWING NO
MATERIAL SEE NOTES		FINISH SEE NOTES	WEIGHT 1.82 GRAMS	A3	00779
		CUSTOMER DRAWING		SCALE 1:1	SHEET 2 OF 6
				RESTRICTED TO -	REV D

REVISIONS					
P	LTR	DESCRIPTION	DATE	DWN	APVD
-	-	SEE SHEET 1	-	-	-

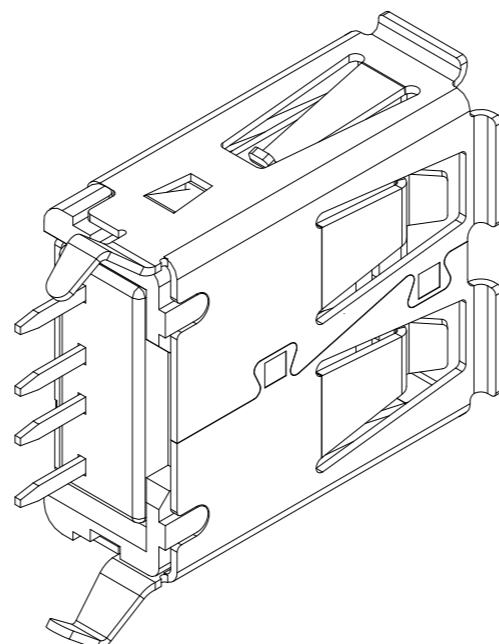
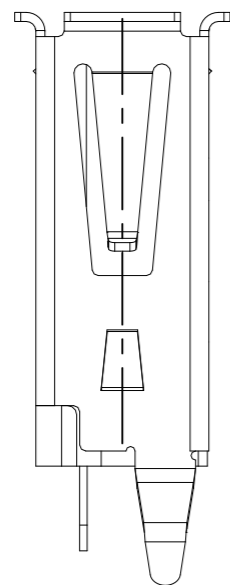

1734366-7 AS SHOW
OTHER DIMENSIONS ARE THE SAME AS SHEET1

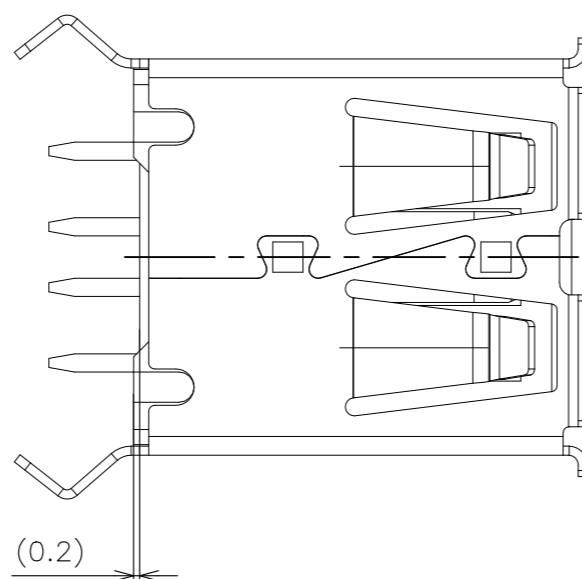
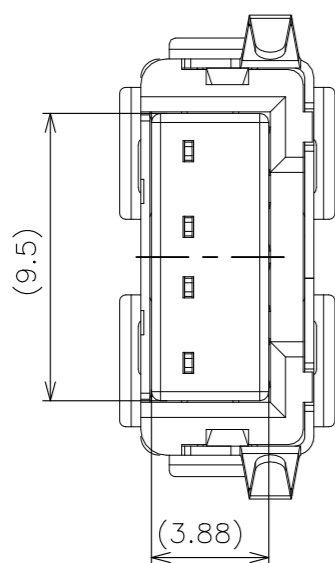

SEE SHEET 4	BLACK	1734366-7	△	△
PACKING	HSG'S COLOR	PART NUMBER	HOUSING MATERIAL	SHIELD FINISH

THIS DRAWING IS A CONTROLLED DOCUMENT.	
DIMENSIONS: mm	TOLERANCES UNLESS OTHERWISE SPECIFIED:
	0 PLC ± 0.38
	1 PLC ± 0.25
	2 PLC ± 0.13
	3 PLC ± 0.05
	4 PLC ± -
	ANGLES ± 2°
MATERIAL SEE NOTES	FINISH SEE NOTES

DWN S. CHIEN 19SEP2008	STE TE Connectivity			
CHK S. CHIEN 19SEP2008				
APVD W.KODAMA	NAME RECEPT ASSY,VERTICAL,4POSITION THRU-HOLE,TYPE A USB			
PRODUCT SPEC 108-57547	SIZE	CAGE CODE	DRAWING NO	RESTRICTED TO
APPLICATION SPEC 501-57635	A3	00779	C-1734366	-
WEIGHT 1.82 GRAMS	CUSTOMER DRAWING		SCALE 1:1	SHEET 3 OF 6
			REV D	

REVISIONS					
P	LTR	DESCRIPTION	DATE	DWN	APVD
	-	SEE SHEET 1	-	-	-

USE THE TAPE TO FIX THE TRAY(4X)

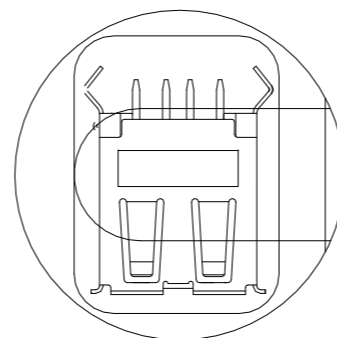
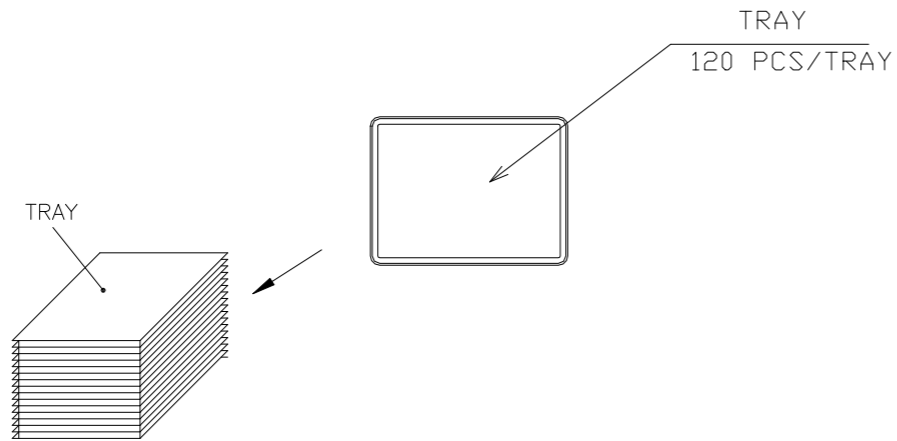

VIEW A:

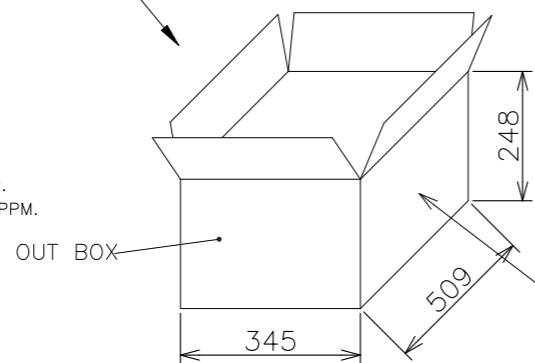
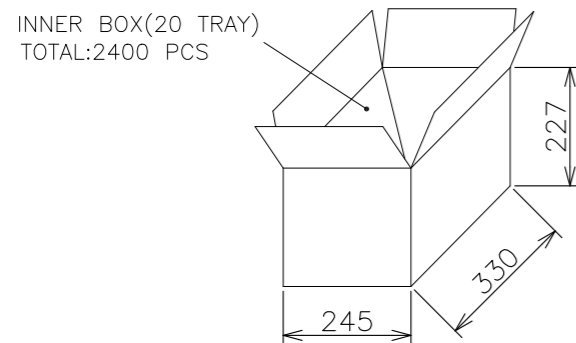
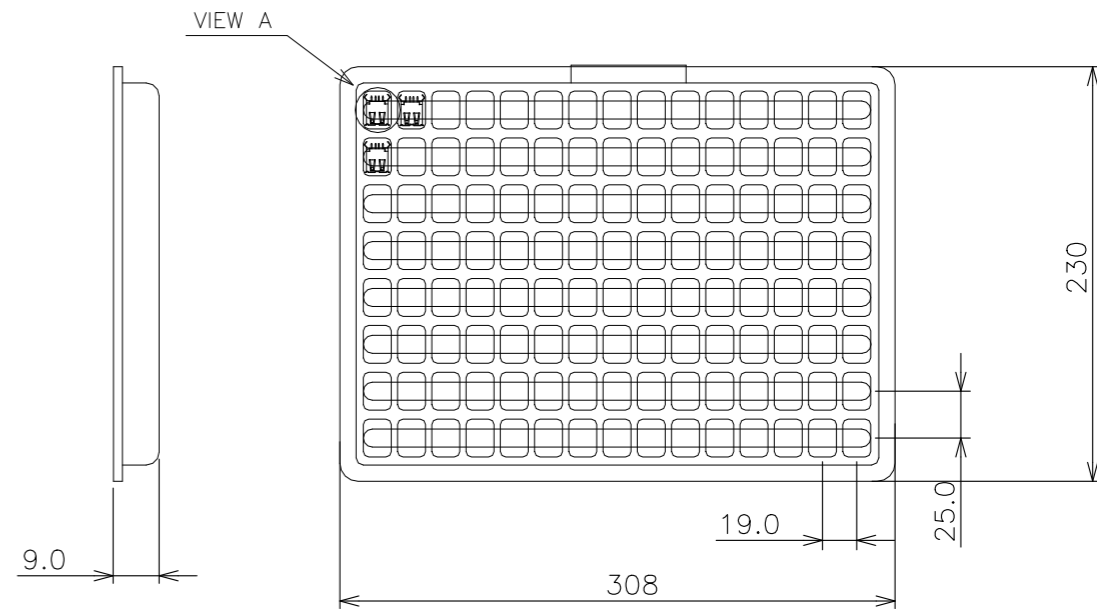

CARTON
 2:INNER BOX/CARTON
 TOTAL:4800PCS
 GROSS WEIGHT:12.2 KGS
 NET WEIGHT:11.2 KGS

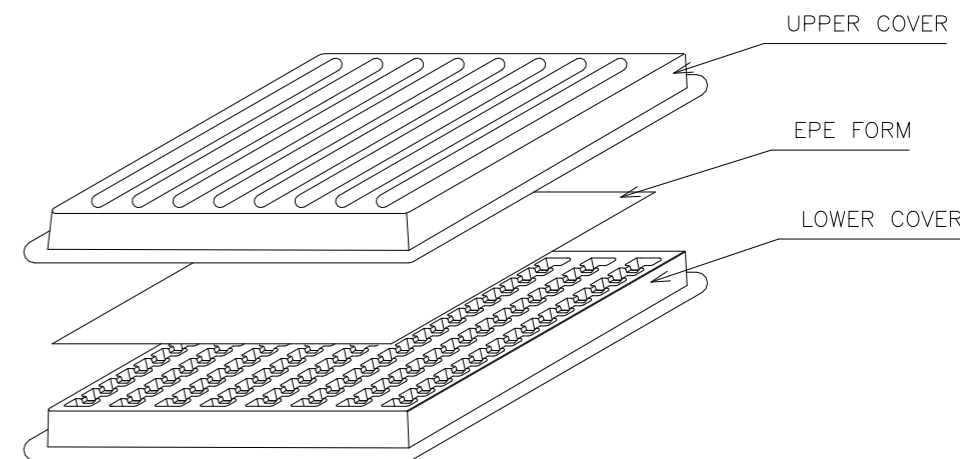

NOTE :
 1. PACKAGING MATERIAL IN PLASTIC, RUBBER,INK,PIGMENT AND PAINT
 MUST MEET CONTROLLED SUBSTANCES SPEC PER 230-702.
 * CADMIUM AND CADMIUM COMPOUNDS NOT TO EXCEED:5 PPM.
 * LEAD,CADMIUM,CHROM VI AND MERCURY NOT TO EXCEED:100 PPM(COMBINED).
 2. MATERIAL :
 TRAY: PVC, UPPER COVER THICKNE=0.3MM.
 LOWER COVER THICKNE=0.4MM

4800	1734366-7
4800	1734366-5
4800	1734366-2
4800	1734366-1
QTY	PART NUMBER

THIS DRAWING IS A CONTROLLED DOCUMENT.		DWN S. CHIEN 19SEP2008	TE Connectivity RECEIPT ASSY,VERTICAL,4POSITION THRU-HOLE,TYPE A USB		
DIMENSIONS: mm		CHK S. CHIEN 19SEP2008			
TOLERANCES UNLESS OTHERWISE SPECIFIED:		APVD W.KODAMA	PRODUCT SPEC	SIZE	CAGE CODE
0 PLC ± 0.38 1 PLC ± 0.25 2 PLC ± 0.13 3 PLC ± 0.05 4 PLC ± - ANGLES ± 2°		APPLICATION SPEC	108-57547	DRAWING NO	
MATERIAL SEE NOTES		FINISH	501-57635	WEIGHT	1.82 GRAMS
			CUSTOMER DRAWING	SCALE	1:1
				SHEET	4 OF 6
				REV	D

REVISIONS					
P	LTR	DESCRIPTION	DATE	DWN	APVD
-	-	SEE SHEET 1	-	-	-

USE THE TAPE TO FIX THE TRAY(4X)

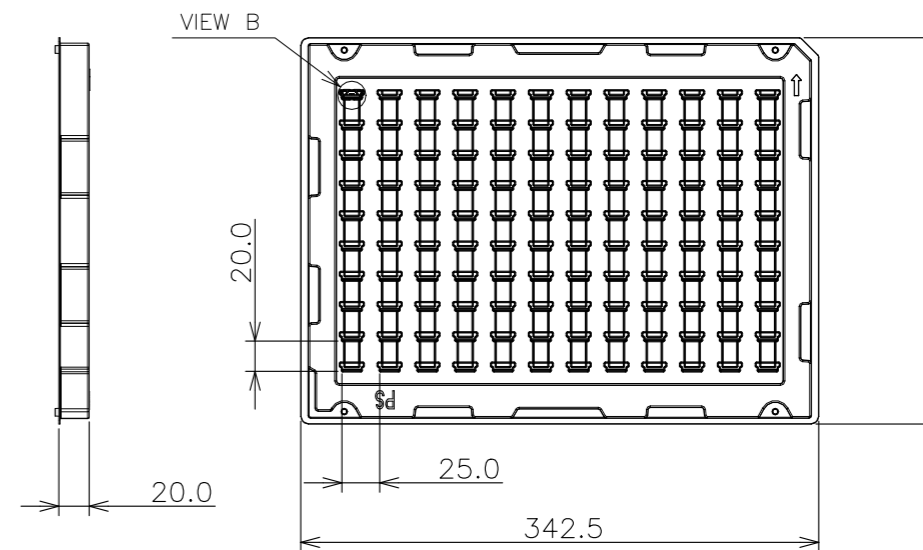
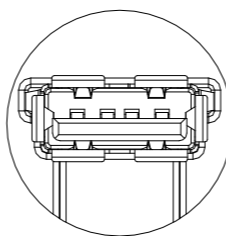
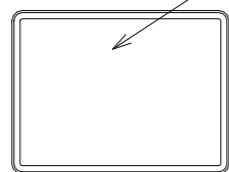
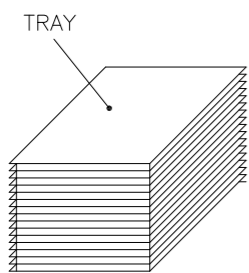

INNER BOX(10 TRAY)
TOTAL:1200 PCS

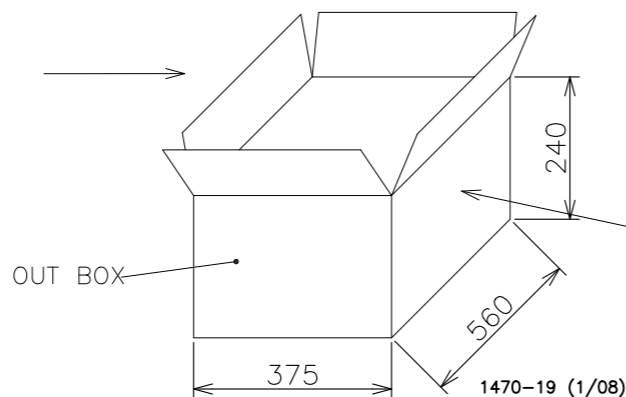
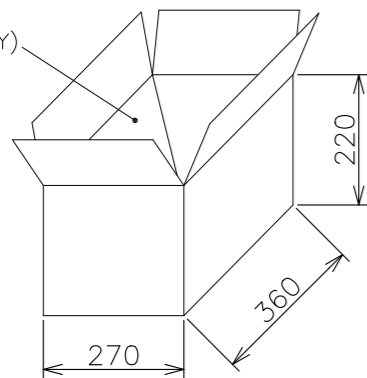

20 TRAYS/CARTON
TOTAL:2400PCS
GROSS WEIGHT:7.2KGS
NET WEIGHT:5.6KGS

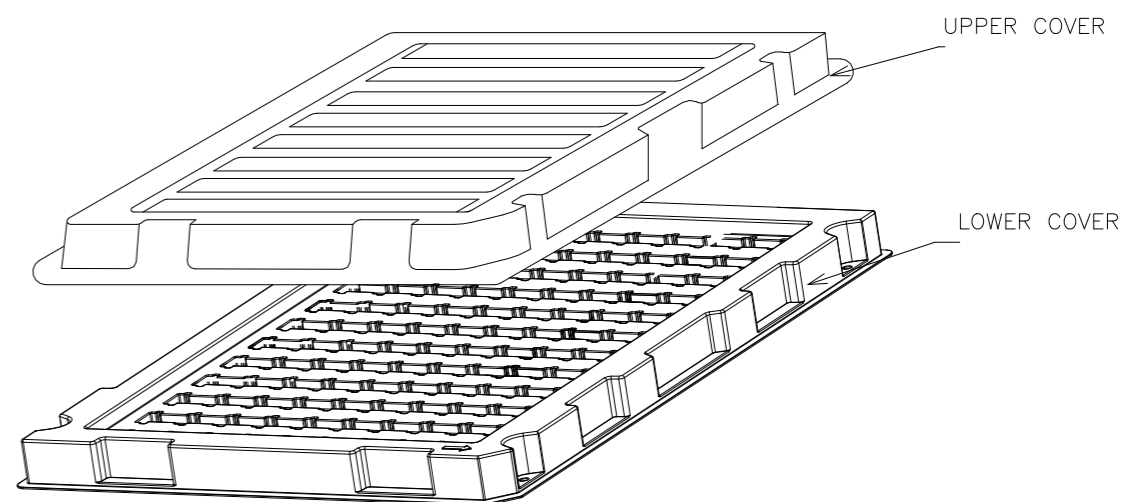

- NOTE :
- PACKAGING MATERIAL IN PLASTIC, RUBBER,INK,PIGMENT AND PAINT
MUST MEET CONTROLLED SUBSTANCES SPEC PER 230-702.
* CADMIUM AND CADMIUM COMPOUNDS NOT TO EXCEED:5 PPM.
* LEAD,CADMIUM,CHROM VI AND MERCURY NOT TO EXCEED:100 PPM(COMBINED).
 - MATERIAL :
TRAY: PS, UPPER COVER THICKNE=0.5MM.
LOWER COVER THICKNE=0.7MM

2400	1734366-4
2400	1734366-3
QTY	PART NUMBER

THIS DRAWING IS A CONTROLLED DOCUMENT.		DWN S. CHIEN 19SEP2008	TE Connectivity RECEIPT ASSY,VERTICAL,4POSITION THRU-HOLE,TYPE A USB		
DIMENSIONS: mm		CHK S. CHIEN 19SEP2008			
TOLERANCES UNLESS OTHERWISE SPECIFIED:		APVD W.KODAMA	NAME		
0 PLC ± 0.38 1 PLC ± 0.25 2 PLC ± 0.13 3 PLC ± 0.05 4 PLC ± - ANGLES ± 2°		PRODUCT SPEC 108-57547	SIZE		
MATERIAL SEE NOTES		APPLICATION SPEC 501-57635	CAGE CODE A300779	DRAWING NO C-1734366	RESTRICTED TO
FINISH SEE NOTES		WEIGHT 1.82 GRAMS	SCALE 1:1		
		CUSTOMER DRAWING	SHEET 5 OF 6		REV D

P	LTR	DESCRIPTION	DATE	DWN	APVD
-	-	SEE SHEET 1	-	-	-

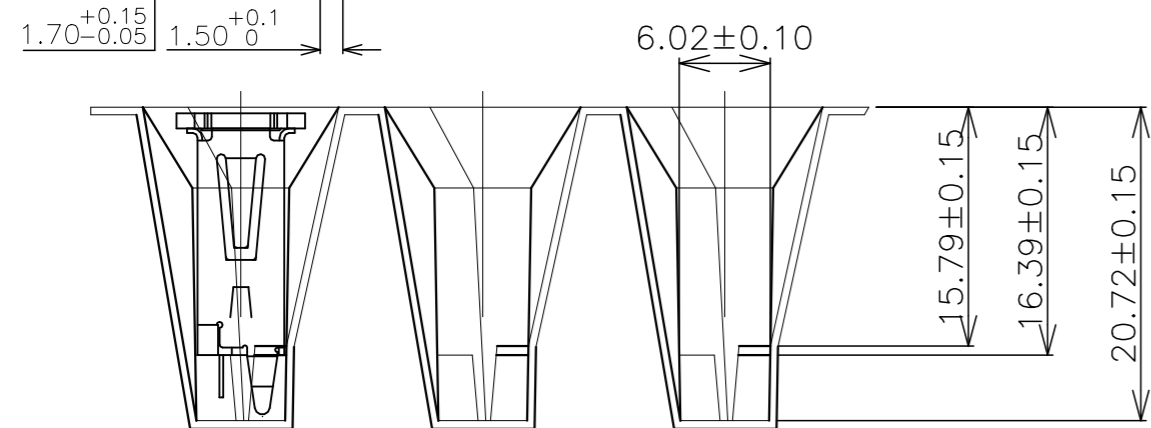
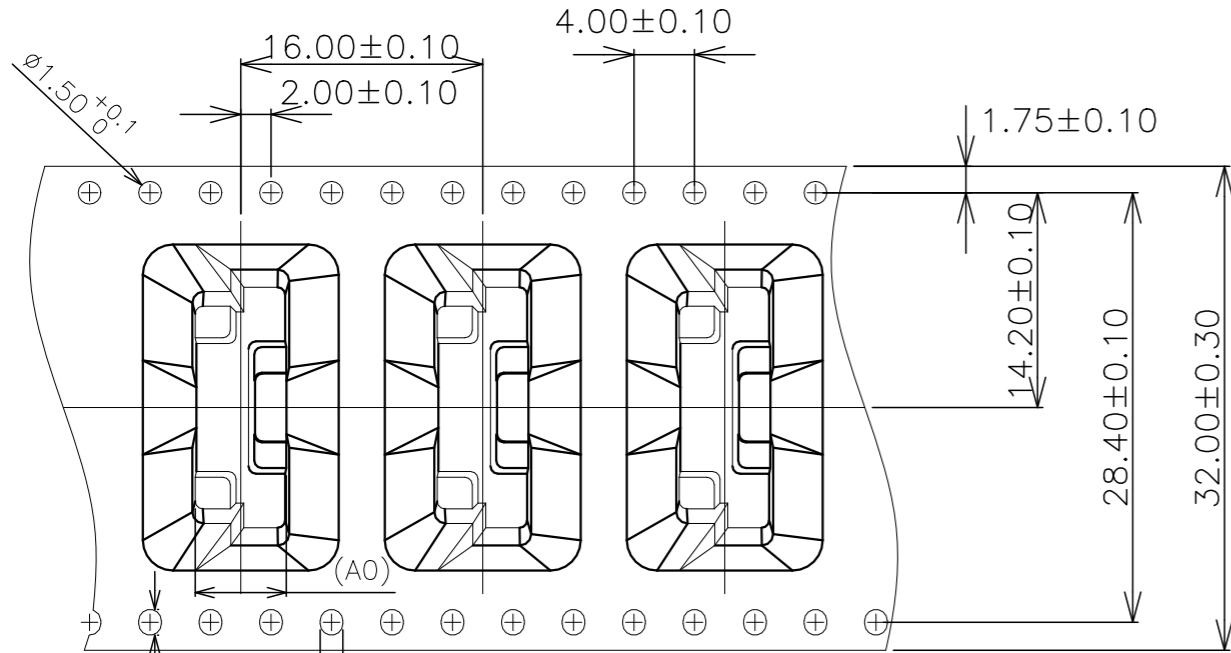

NOTE :

1. PACKAGING MATERIAL IN PLASTIC, RUBBER,INK,PIGMENT AND PAINT
MUST MEET CONTROLLED SUBSTANCES SPEC PER 230-702.
* CADMIUM AND CADMIUM COMPOUNDS NOT TO EXCEED:5 PPM.
* LEAD,CADMIUM,CHROM VI AND MERCURY NOT TO EXCEED:100 PPM(COMBINED).
2. MATERIAL :
REEL:BLACK CONDUCTIVE POLYSTYRENE ALLOY

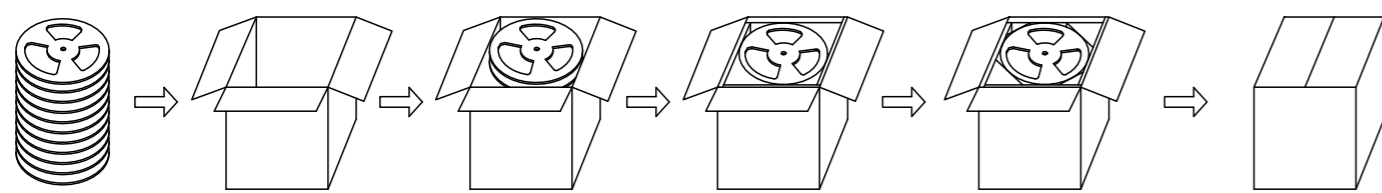
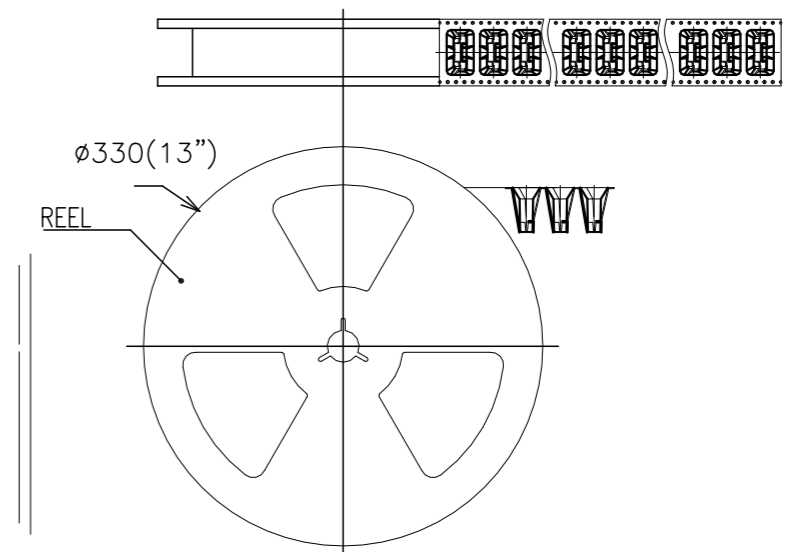
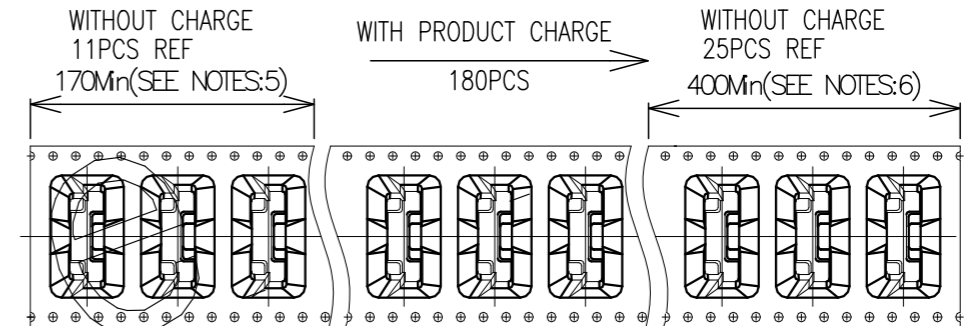

OUT BOX PACKAGE DIAGEAM DRAWING

1440	1734366-6
QTY	PART NUMBER

THIS DRAWING IS A CONTROLLED DOCUMENT.		DWN S. CHIEN 19SEP2008	TE Connectivity RECEIPT ASSY,VERTICAL,4POSITION THRU-HOLE,TYPE A USB		
DIMENSIONS: mm		CHK S. CHIEN 19SEP2008			
TOLERANCES UNLESS OTHERWISE SPECIFIED:		APVD W.KODAMA	PRODUCT SPEC		
0 PLC ± 0.38		APPLICATION SPEC		108-57547	
1 PLC ± 0.25		WEIGHT		501-57635	
2 PLC ± 0.13		SIZE		A3	
3 PLC ± 0.05		CAGE CODE		00779	
4 PLC ± -		DRAWING NO		C-1734366	
ANGLES ± 2°		RESTRICTED TO		-	
MATERIAL SEE NOTES		CUSTOMER DRAWING		SCALE 1:1	
FINISH SEE NOTES		SHEET 6 OF 6		REV D	

单击下面可查看定价，库存，交付和生命周期等信息

[>>TE Connectivity\(泰科\)](#)