

THIS DRAWING IS UNPUBLISHED. RELEASED FOR PUBLICATION, 19 .  
 © COPYRIGHT 19 BY AMP INCORPORATED. ALL INTERNATIONAL RIGHTS RESERVED.

| LOC | DIST | P | F | ZONE | LTR | DESCRIPTION                    | DATE    | APPD    |
|-----|------|---|---|------|-----|--------------------------------|---------|---------|
| G   | 14   |   |   |      | D   | REV & REDRAWN PER 0720-0061-93 | 4-19-93 | APP DAP |

**METRIC**  
 DIMENSIONS LISTED IN mm [ INCHES ]

|                                |                            |
|--------------------------------|----------------------------|
| <b>AMP</b><br>WIRE RANGE       | <b>UL</b> E13288<br>Listed |
| 22-16 AWG<br>SOLID OR STRANDED | NOT<br>APPLICABLE          |
| <b>SR</b> LR7189<br>Certified  | MILITARY P/N<br>AND CLASS  |
| NOT<br>APPLICABLE              | NOT APPLICABLE             |

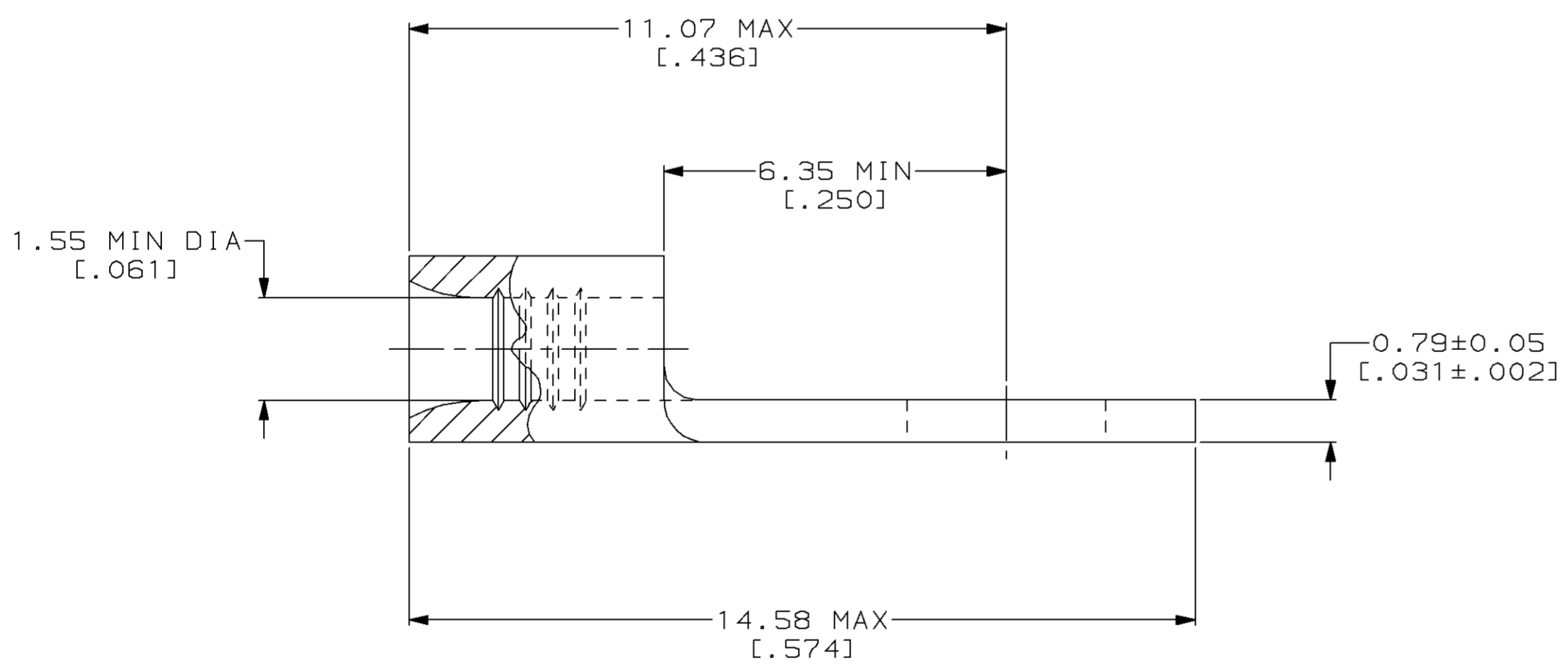
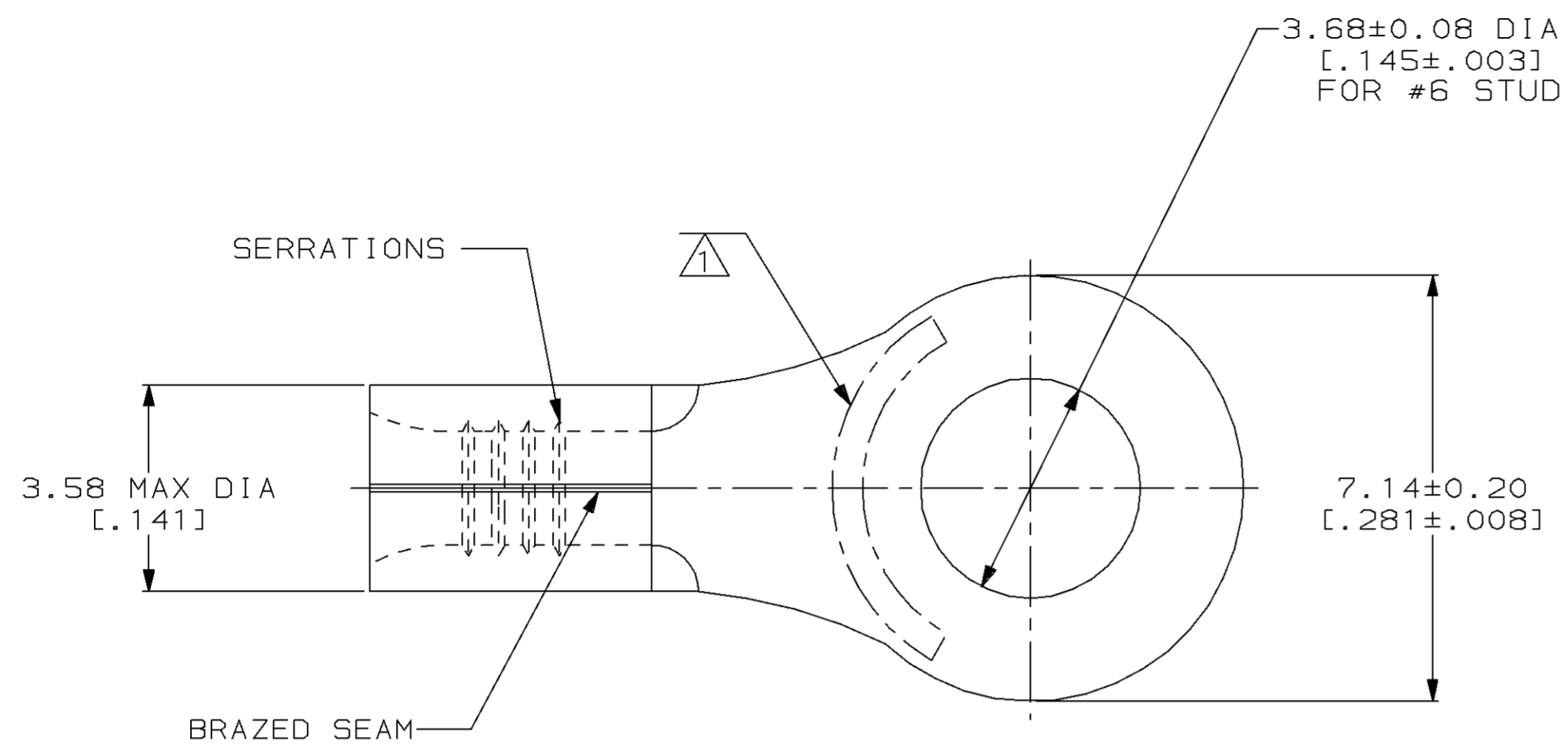

|  |  |   |  |                             |  |                       |                        |
|--|--|---|--|-----------------------------|--|-----------------------|------------------------|
| AMP INCORPORATED<br>CUSTOMER SERVICE SYSTEMS                                     |  | MAX RECOMMENDED OPERATING TEMPERATURE:<br>343°C MAX   | DO NOT SCALE PRINT.<br>UNLESS SPECIFIED<br>DIMENSIONS IN mm [INCHES]<br>TOLERANCES ON:<br>2 PLC DEC ± -<br>3 PLC DEC ± -<br>ANGLES ± - | DR 4-19-93<br>TA BRINKMAN   | <b>AMP</b> AMP Incorporated<br>Harrisburg, PA 17105-3608           |                       |                        |
| FOR ADDITIONAL PRODUCT INFORMATION OR COPIES OF DRAWINGS AND TECHNICAL DOCUMENTS | PRODUCT INFORMATION CENTER<br>1-800-522-6752 | VOLTAGE RATING:<br>NOT APPLICABLE   | MATERIAL<br>COPPER PER<br>ASTM B-152<br>ANNEALED   | CHK 4-19-93<br>DA PATTERSON | NAME<br>TERMINAL, RING TONGUE,<br>HEAT RESISTANT,<br>STRATO-THERM™ |                       |                        |
| FOR APPLICATION TOOLING INFORMATION  | TOOLING ASSISTANCE CENTER<br>1-800-722-1111  | WIRE CROSS SECTIONAL AREA RANGE:<br>0.26-1.65mm <sup>2</sup> [509-3,260] CIR MILS<br>SOLID OR STRANDED  | FINISH<br>NICKEL PLATE<br>0.00762[.000300] MIN<br>THK PER QQ-N-290   | APPD 4-19-93<br>DE MILLER   | SIZE<br>00779  | CAGE CODE<br>C=323219 | DRAWING NO<br>C=323219 |
| FOR ORDER ENTRY  | 1-800-526-5142                               | THIS DRAWING IS A CONTROLLED DOCUMENT FOR AMP INCORPORATED. IT IS SUBJECT TO CHANGE AND THE CONTROLLING ENGINEERING ORGANIZATION SHOULD BE CONTACTED FOR THE LATEST REVISION. |  | APPD 4-19-93<br>JL MECKLEY  | SCALE<br>10:1  |                       | SHEET<br>1 OF 1        |

单击下面可查看定价，库存，交付和生命周期等信息

[>>TE Connectivity\(泰科\)](#)