

LOC	DIST	REVISIONS			
P	U/R	DESCRIPTION	DATE	DWN	APVD
GP	00	L	REV PER EC 0512-0217-03	12MAY03	AWF AWF

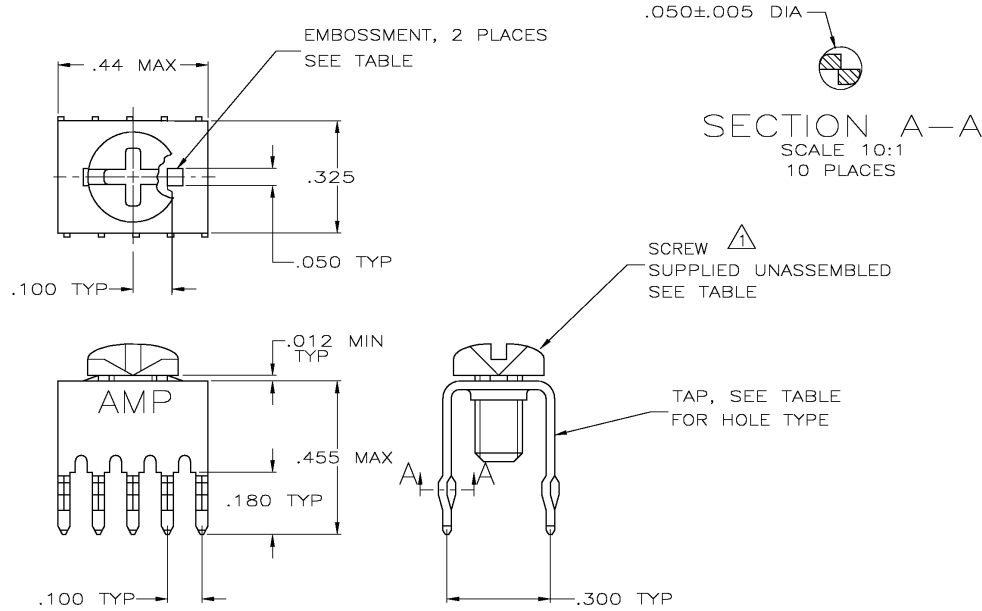

- ① TO PREVENT THREAD STRIPPING, SCREW TORQUE SHOULD NOT EXCEED 9 IN LBS.
- ② TAP HOLE IS 6-32UNC-2B, TWO MIN THREADS.
- ③ TAP HOLE IS M4 X 0.7, TWO MIN THREADS.
- ④ TAP: .000150 TIN-LEAD OVER .000050 NICKEL.
- ⑤ TAP: .000150 TIN OVER .000050 NICKEL.

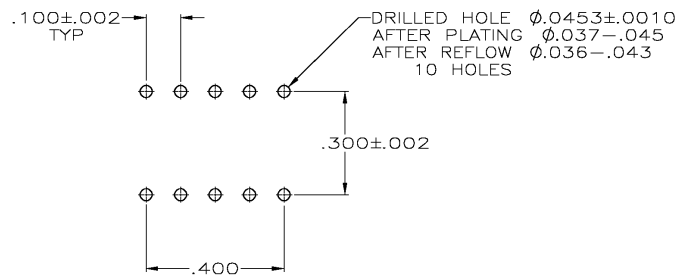

SUPERSEDED BY -4	FINISH	HOLE TYPE	SCREW	EMBOSSMENT	PART NUMBER
					9-55558-0
	④	③	NO	YES	1-55558-1
	④	②	993879-1	NO	55558-8
		②	NO	NO	55558-7
	④	②	993879-1	YES	55558-4
		②	NO	YES	55558-3

THIS DRAWING IS A CONTROLLED DOCUMENT.		DWN J. McCLINTON 1-11-88	Tyco Electronics Corporation City, State, Zip	
DIMENSIONS: INCHES		CHK R. STONE 1-11-88	NAME M. GALLOWAY 1-11-88	
TOLERANCES UNLESS OTHERWISE SPECIFIED:		PRODUCT SPEC		
0 PLC	± .005	APPLICATION SPEC		
1 PLC	± .004	SIZE		
2 PLC	± .003	CAGE CODE		
3 PLC	± .002	DRAWING NO		
4 PLC	± .001	RESTRICTED TO		
ANGLES	± .001	A2 00779 ©-55558		
MATERIAL COPPER ALLOY 725.	FINISH ④⑤	WEIGHT	SCALE 4:1 SHEET 1 OF 1 REV L	
CUSTOMER DRAWING				

单击下面可查看定价，库存，交付和生命周期等信息

[>>TE Connectivity\(泰科\)](#)