

REVISIONS				
P	LTR	DESCRIPTION	DATE	OWN
E		REVISED PER ECO-16-017894	26APR2017	PHM CT

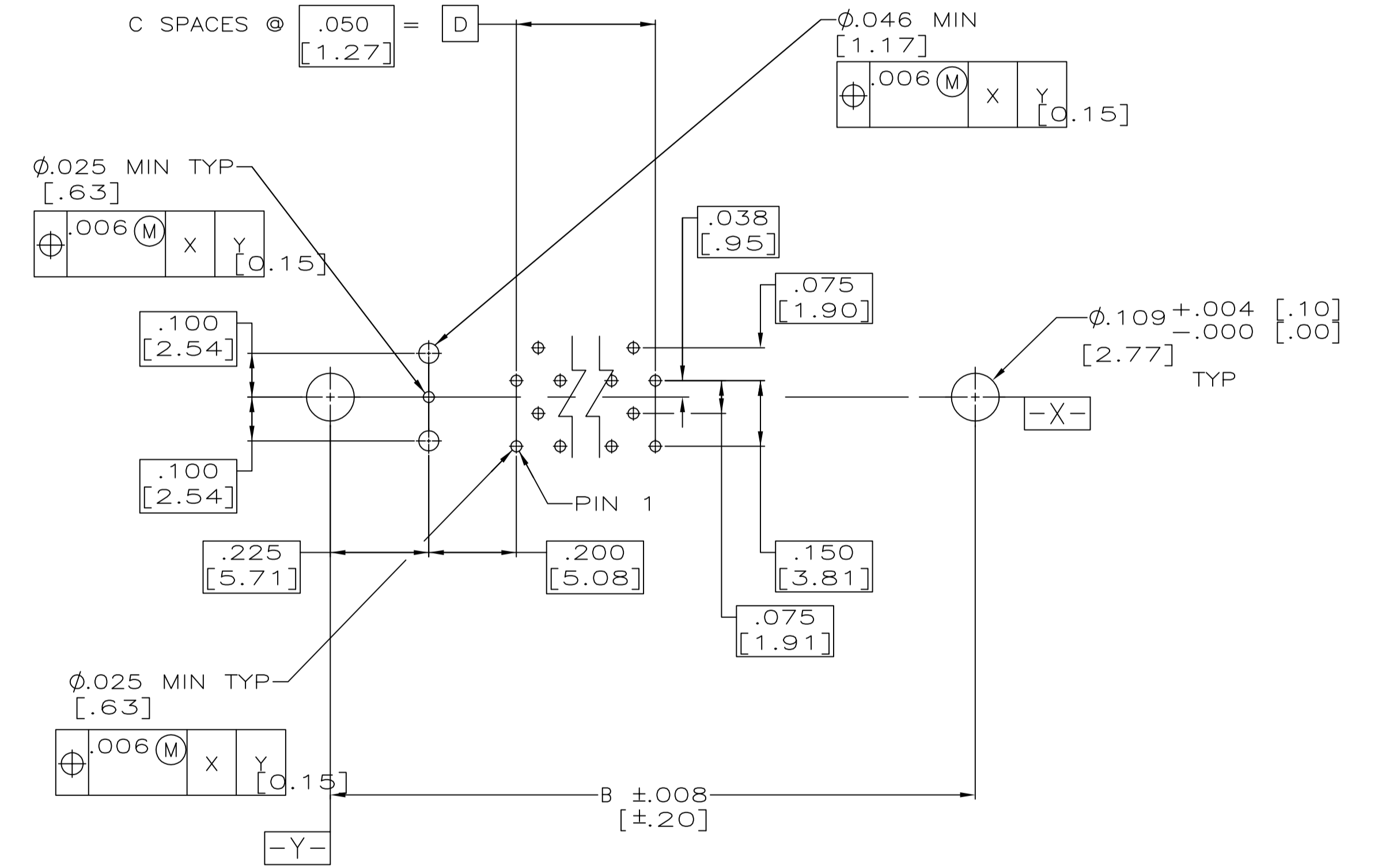
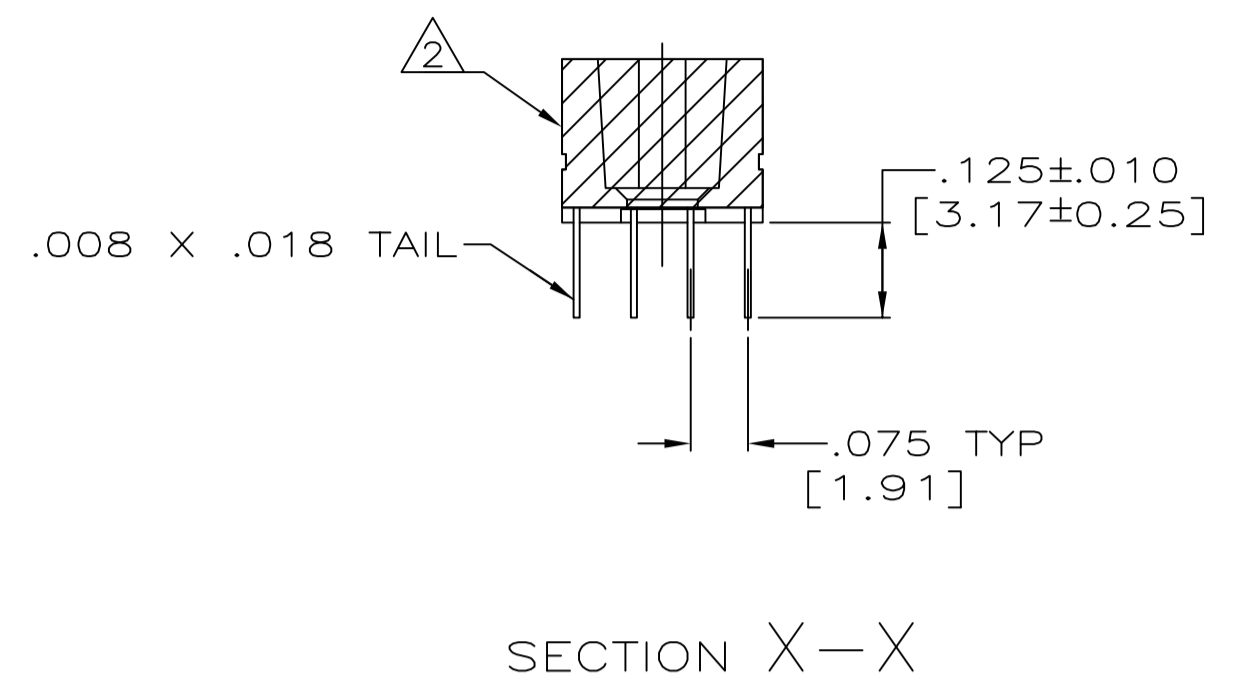
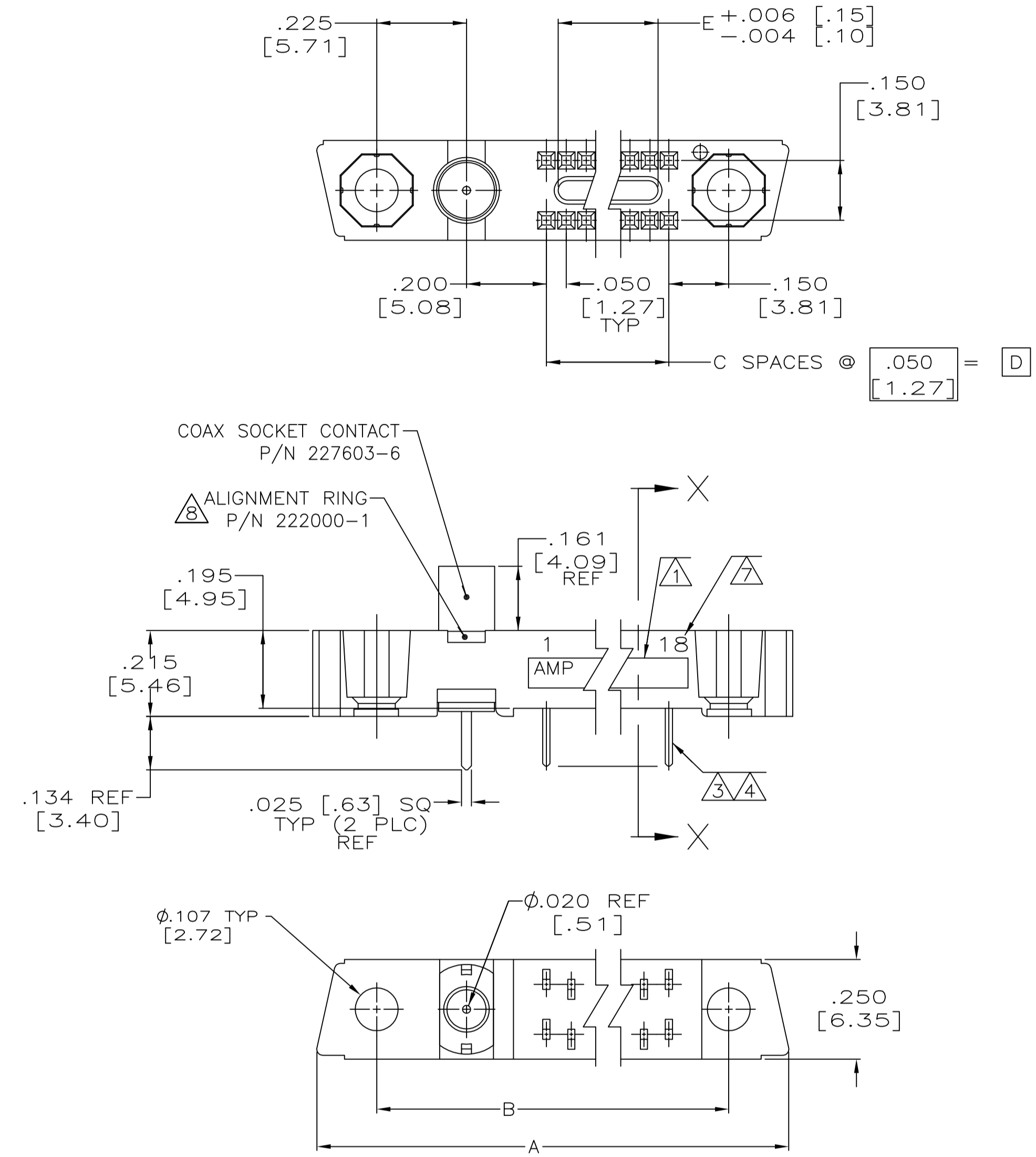

P.C. BOARD LAYOUT (CONNECTOR SIDE)

- ① AMP, AMP PART NO. AND DATE CODE MARKED IN THIS APPROXIMATE AREA.
- ② HOUSING MATERIAL: LIQUID CRYSTAL POLYMER PER MIL-M-24519, GLCP-30F; COLOR: GRAY.
- ③ CONTACT: MATERIAL = PHOS BRONZE
- ④ PLATED .000030 GOLD IN THE CONTACT AREA, .000100 MIN TIN LEAD ON THE TAILS, ALL OVER .000050 NICKEL UNDER PLATE.
- ⑤ MICRO-MINATURE COAX CONTACT PER AMP DATA SHEET 80-600, PC BOARD MOUNTED CONTACTS MUST BE MATED BEFORE SOLDERING.

- 6. GROUP "A" INSPECTION PER MIL-C-55302 PERFORMED.
- ⑥ NUMBERS INDICATING END POSITIONS MARKED THIS SIDE ONLY.
- ⑦ ALIGNMENT RING MUST BE FLUSH TO BELOW MATING FACE.
- 9. MEETS SEALING EFFECTIVENESS TEST REQUIREMENT.

.700 [17.78]	.850 [21.59]	17	1.425 [36.20]	1.715 [43.56]	1	36	449874-1
E	D	C	B	A	NUMBER OF COAX POS.	NUMBER OF BOX POS.	PART NUMBER
THIS DRAWING IS A CONTROLLED DOCUMENT.					OWN T. ALEXANDER 4-5-94		
DIMENSIONS:					D.W. D. GUTTER 4-12-94		
INCHES:					APVD D. GUTTER 4-12-94		
0 PLC ± -					NAME		
1 PLC ± -					RECEPTACLE ASSEMBLY, MINI-BOX		
2 PLC ± -					W/ ONE COAX PORT, AND LOW FORCE CONTACTS		
3 PLC ± .010 [0.25]					SPECIAL		
4 PLC ± -					APPLICATION SPEC		
ANGLES ± -					SIZE CAGE CODE DRAWING NO		
FINISH					RESTRICTED TO		
MATERIAL					WEIGHT		
② ③					A1 00779 C=449874		
CUSTOMER DRAWING					SCALE 4:1 SHEET 1 OF 1 REV E		

单击下面可查看定价，库存，交付和生命周期等信息

[>>TE Connectivity\(泰科\)](#)