

THIS DRAWING IS UNPUBLISHED.

RELEASED FOR PUBLICATION

ALL RIGHTS RESERVED.

© COPYRIGHT - By -

LOC	DIST	REVISIONS					
		P	LTR	DESCRIPTION	DATE	DWN	APVD
AF	50		F	REVISED PER ECR-12-013518	23NOV2012	KH	PD

- 1 CONTINUOUS STRIP ON REELS.
- 2 ACCEPTS [#20-#16] AWG. WIRE SIZE
- 3 INSULATION RANGE TO BE 2.79-4.32 [.110-.170] DIA
- 4 FEED IS 16.38±0.13 [.645±.005]
- 5 MATING TAB THK IS 0.81±0.025 [.032±.001].
- △ 6 PREPRODUCTION - FASR REQUIRED

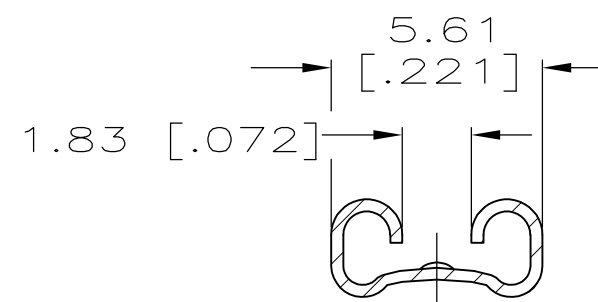
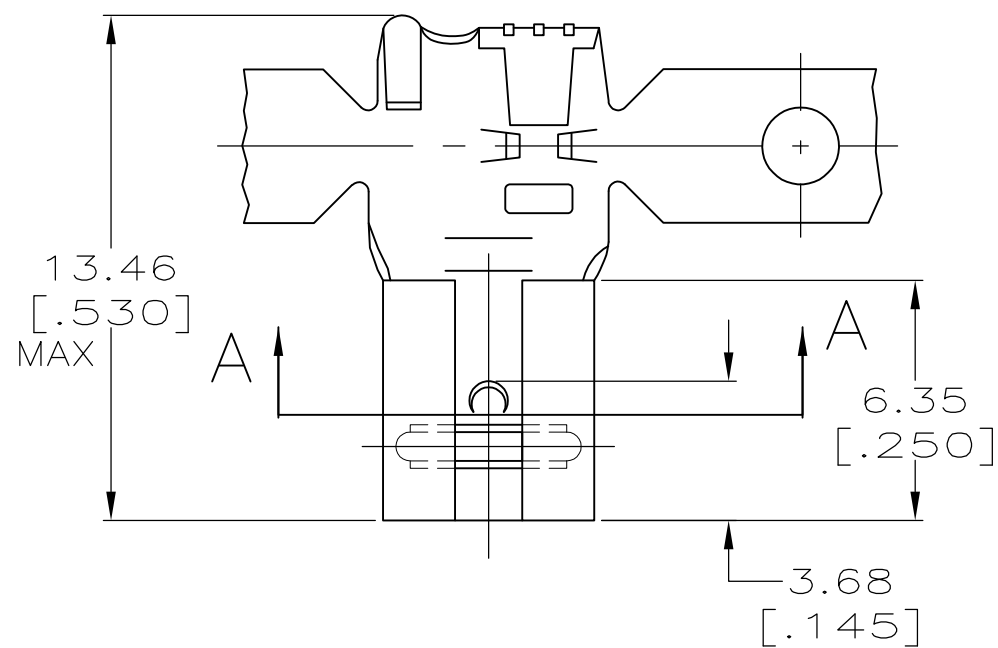

SECTION A-A

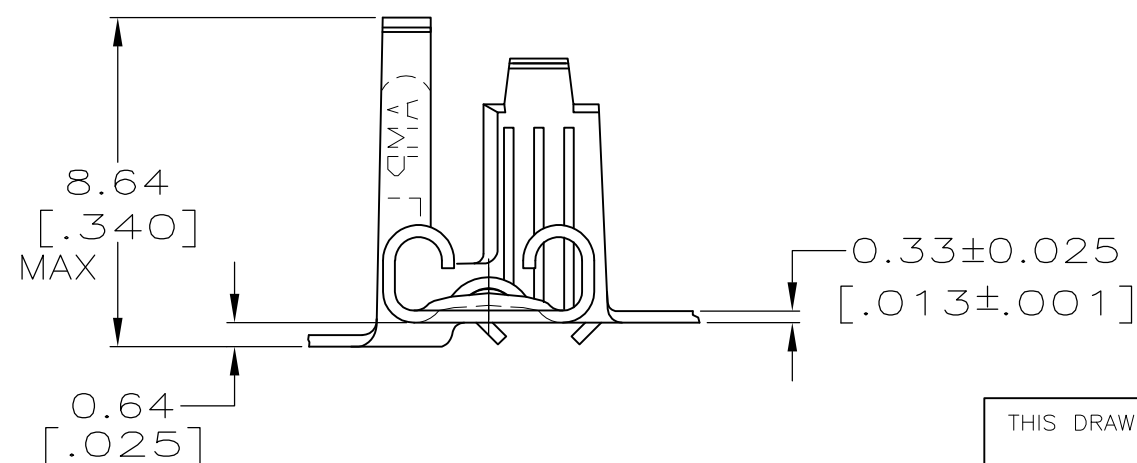

TIN	H04 PHOS BRONZE	△ 6 63748-3
TIN	BRASS	63748-2
---	BRASS	63748-1
FINISH	MATERIAL	PART NO.

THIS DRAWING IS A CONTROLLED DOCUMENT.		DWN	JR RUTH	7/27/93	STE TE Connectivity		
DIMENSIONS: mm [INCHES]		CHK	MS FEHER	7/27/93			
TOLERANCES UNLESS OTHERWISE SPECIFIED:		APVD	R KUZO	7/27/93	NAME		
0 PLC	± -	PRODUCT SPEC		RECEPTACLE, LIF, FASTON, FLAG, 4.75 [.187] SERIES			
1 PLC	± -	APPLICATION SPEC		-			
2 PLC	± 0.25 [.010]	SIZE	A3	CAGE CODE	00779	DRAWING NO	C-63748
3 PLC	± -	WEIGHT		RESTRICTED TO		-	
4 PLC	± -	CUSTOMER DRAWING					
ANGLES	± -	SCALE		5:1		SHEET 1 OF 1	
MATERIAL	SEE TABLE	FINISH		SEE TABLE		REV F	

单击下面可查看定价，库存，交付和生命周期等信息

[>>TE Connectivity\(泰科\)](#)