

REVISIONS					
P	LTR	DESCRIPTION	DATE	DMN	APVD
A		REVISED PER ECO-15-015252	16NOV15	BJ	FY

- 1 HOUSING MATERIAL: THERMOPLASTIC.
- 2 CONTACT MATERIAL: COPPER ALLOY.
- 3 FINISH:
MATING AREA: MEETS THE PERFORMANCE REQUIREMENTS OF PRODUCT SPECIFICATION 108-9063; BASED ON TELCORDIA DR-1217-CORE APPLICATIONS IN UNCONTROLLED ENVIRONMENTS.
SOLDER TAILS AREA: TIN PLATED.
- 4 SOLDER TAILS MUST FIT HOLE PATTERN AS SHOWN ON THE RECOMMENDED P.C. BOARD LAYOUT.
- 5 QUANTITIES OF VOID CORING ARE DEPENDENT ON THE POSITION SIZE OF THE HOUSING.
- 6 OBSOLETE PARTS: OBSOLETE CIS STREAMLINING PER D.RENAUD/D.SINISI

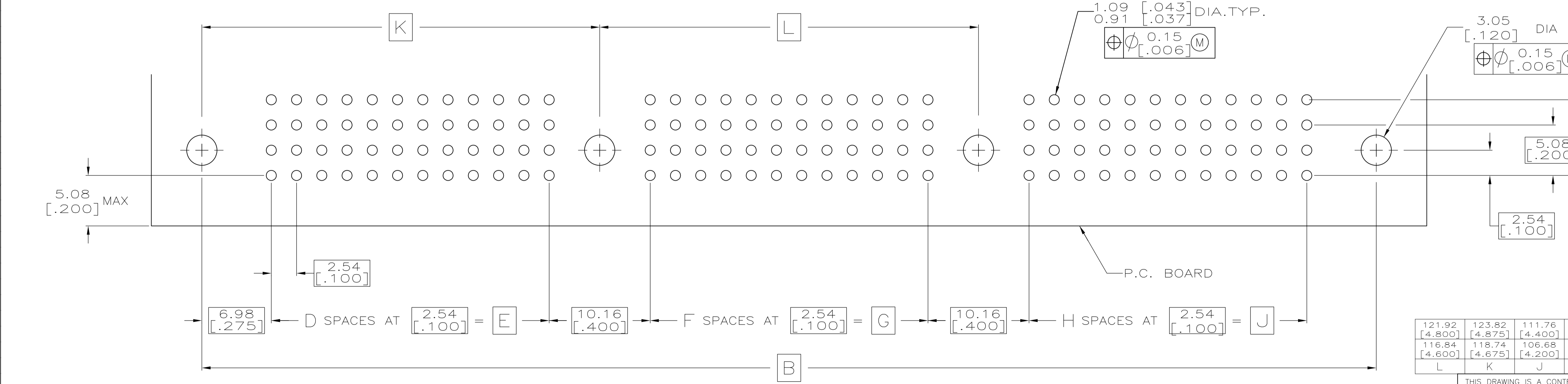
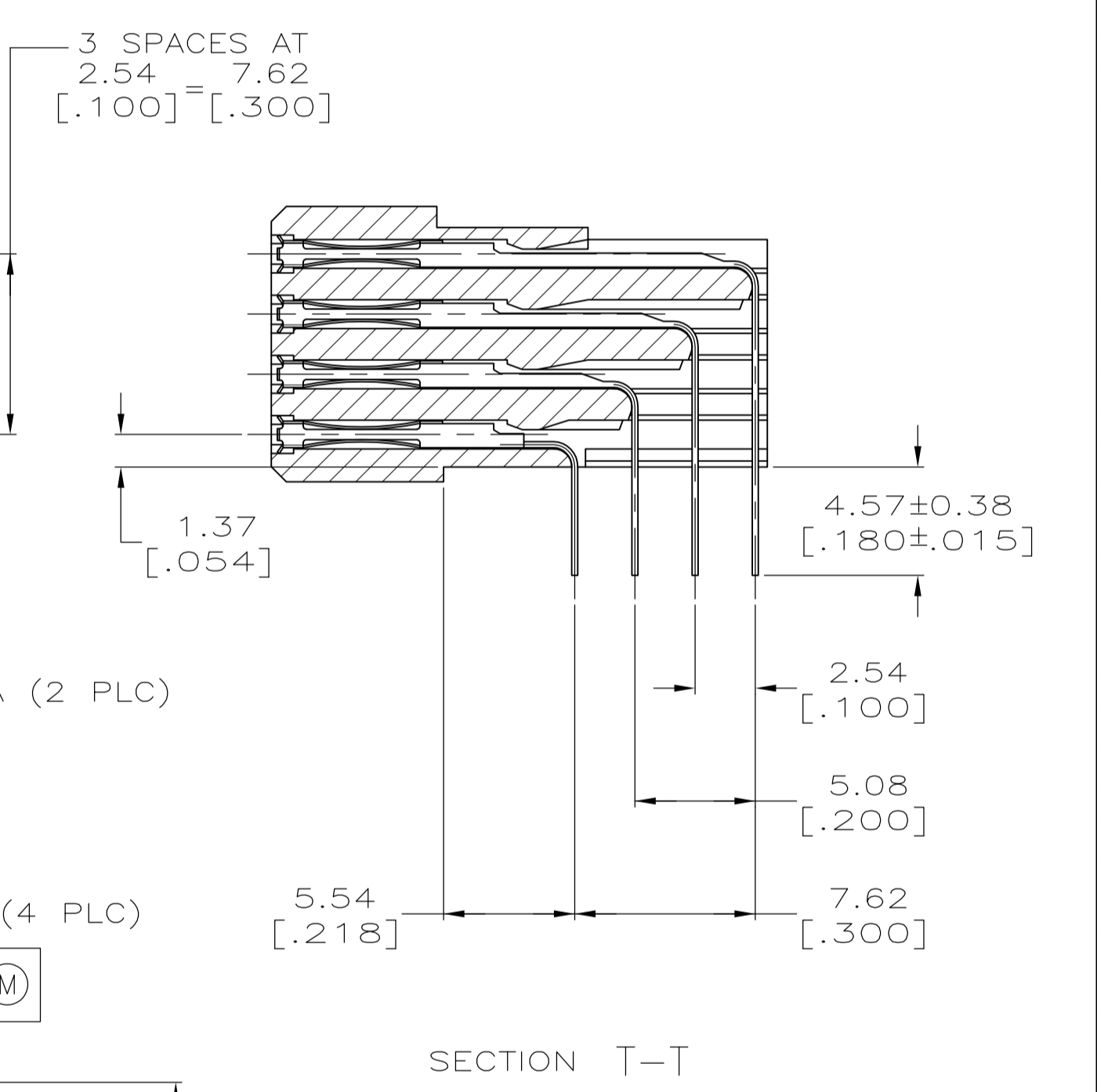
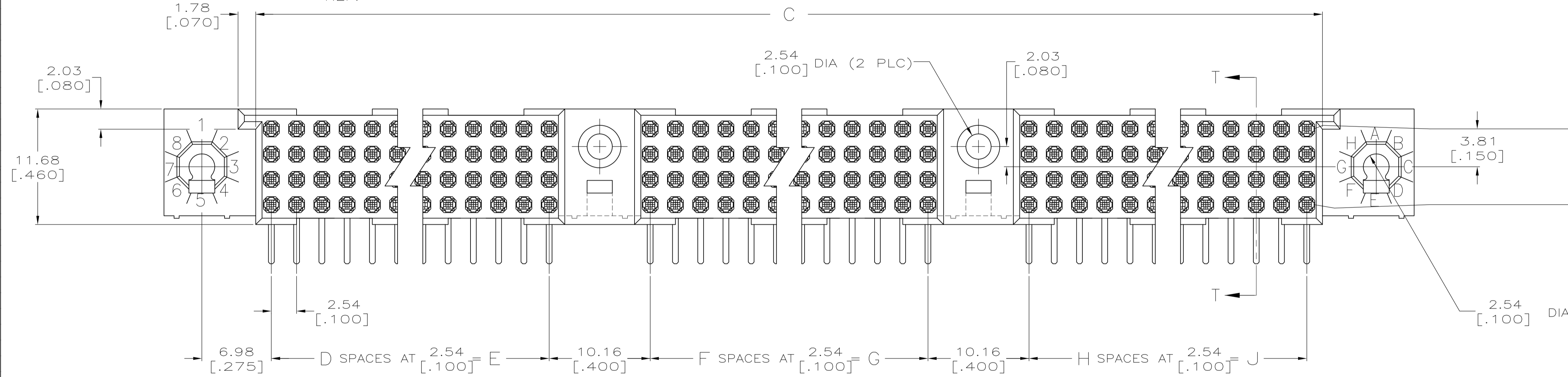
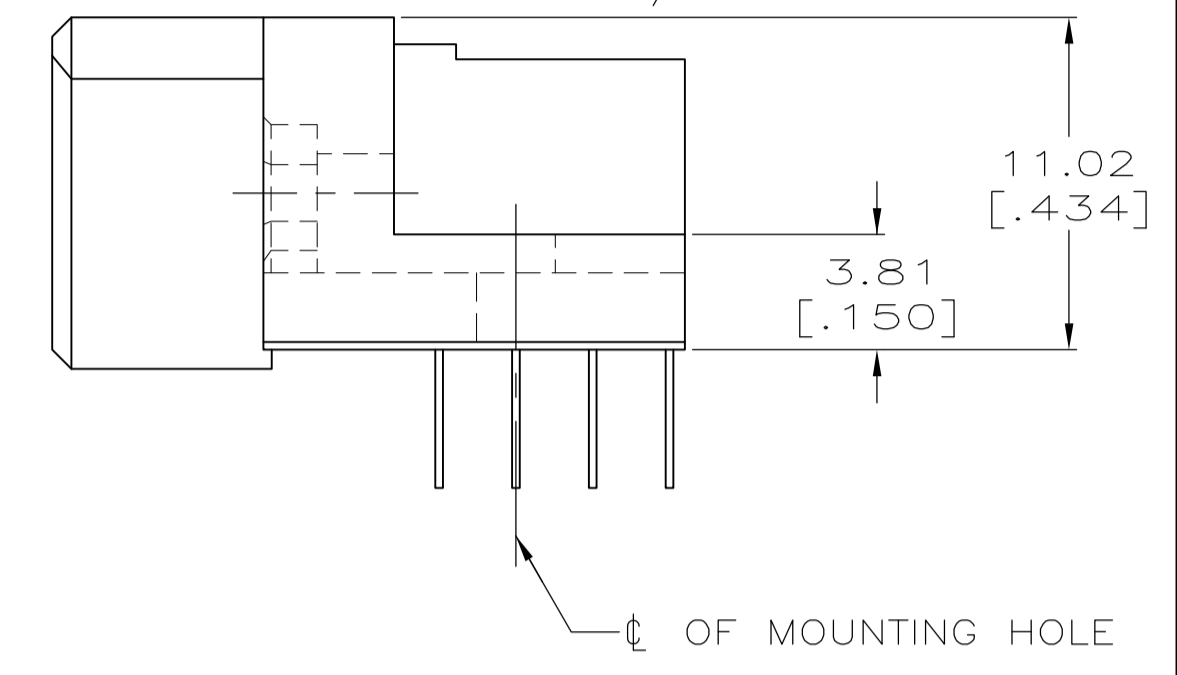
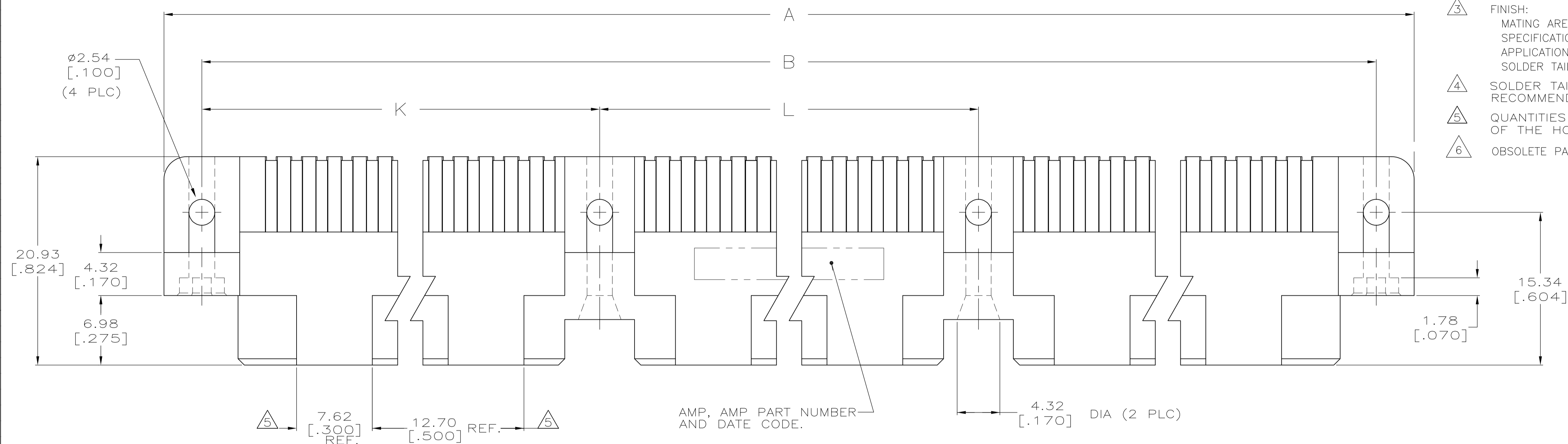

RECOMMENDED P.C. BOARD LAYOUT 4

121.92 [4.800]	123.82 [4.875]	111.76 [4.400]	44	111.76 [4.400]	44	111.76 [4.400]	44	358.75 [14.124]	369.57 [14.550]	377.19 [14.850]	540	5532840-2
116.84 [4.600]	118.74 [4.675]	106.68 [4.200]	42	106.68 [4.200]	42	106.68 [4.200]	42	343.51 [13.524]	354.33 [13.950]	361.95 [14.250]	516	5532840-1
L	K	J	H	G	F	E	D	C	B	A	POSN	PART NUMBER

THIS DRAWING IS A CONTROLLED DOCUMENT.

DIMENSIONS: mm [INCHES]

TOLERANCES UNLESS OTHERWISE SPECIFIED:

0 PLC	± .005
1 PLC	± .005
2 PLC	± .010
3 PLC	± .015
4 PLC	± .020
ANGLES	± .005

MATERIAL: 1 2 FINISH: 3

APPROVED: J. POLIGNONE, A. SHARPE

NAME: ASSEMBLY, RECEPTACLE, RIGHT ANGLE, HDI, LEAD-FREE, 4 ROW, 2 GUIDES, 4.57[.180] SOLDER POSTS

SIZE: A1 00779 C=5532840

CUSTOMER DRAWING SCALE: 4:1 SHEET: 1 OF 1 REV: A

单击下面可查看定价，库存，交付和生命周期等信息

[>>TE Connectivity\(泰科\)](#)