

- 208210 MATES WITH 208209.
- MOUNTING SCREW INFORMATION SEE 208211.
- 208210-1 WILL BE MOLDED WITH AMP PART NUMBER 208210-2 SINCE IT IS AN INK STAMPED VERSION OF 208210-2.

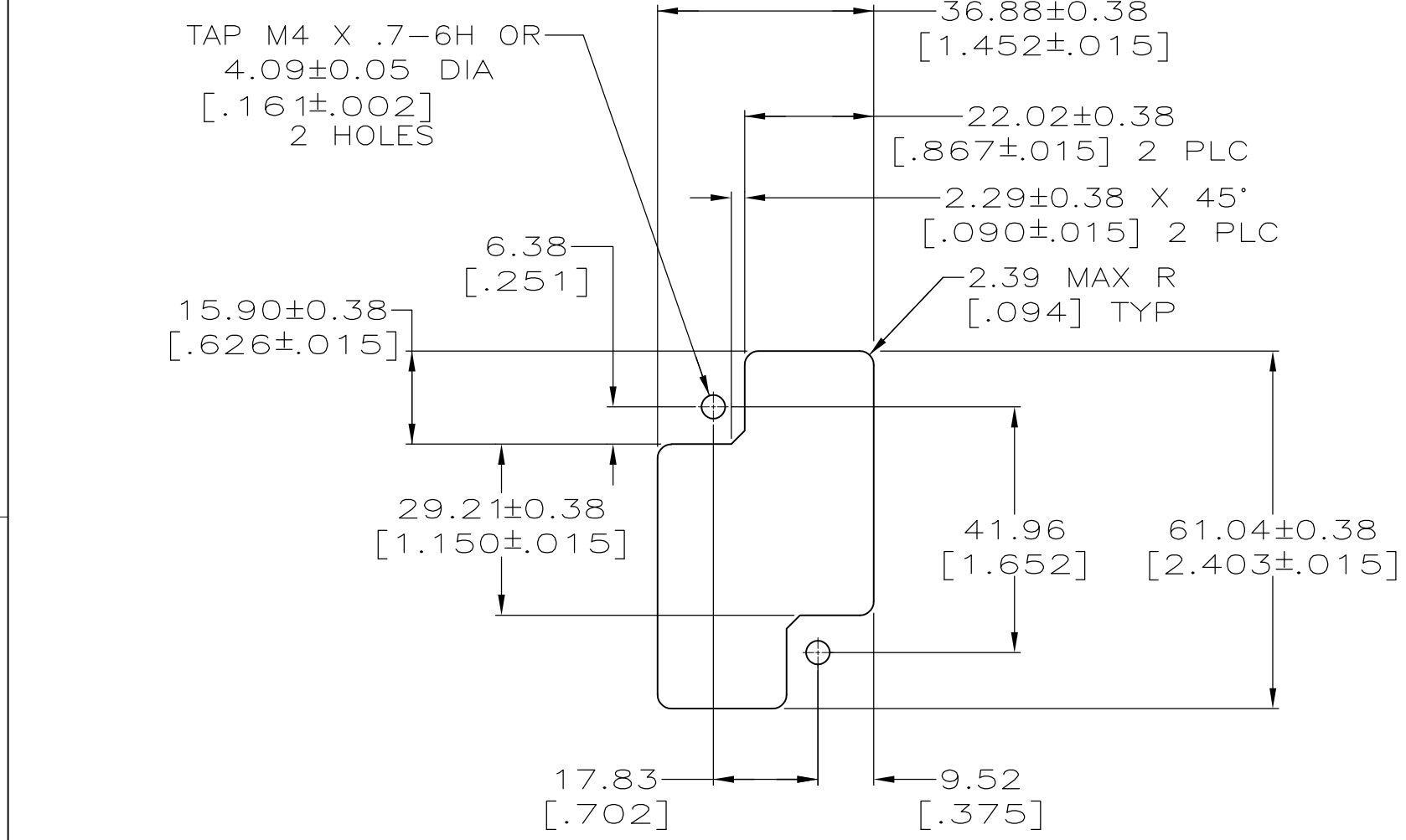

SUGGESTED
PANEL CUTOUT

208210-5	-	POLYESTER, BLUE	208210-5
208210-2	-	POLYESTER, BLACK	208210-2
208210-2 Δ	113P10188	POLYESTER, BLACK	208210-1
MOLDED PART NO	CUST IDENT	MATERIAL	PART NO

THIS DRAWING IS A CONTROLLED DOCUMENT.		DWN R. SHIREY 09/05/91	STE TE Connectivity	
DIMENSIONS: MM[INCHES]		CHK R. STONE 09/23/91		
TOLERANCES UNLESS OTHERWISE SPECIFIED:		APVD A. TRAVIS 09/23/91	NAME	
0 PLC	± -	PRODUCT SPEC	SOCKET HOUSING, 19 POSN, METRIMATE	
1 PLC	± -	APPLICATION SPEC	RESTRICTED TO	
2 PLC	± 0.13 [.005]	114-10039	SIZE	CAGE CODE
3 PLC	± -	WEIGHT -	A2	00779
4 PLC	± -	CUSTOMER DRAWING	DRAWING NO	208210
ANGLES	± 1°	SCALE 1:1	SHEET	1 of 1
FINISH -	-	REV	K1	

单击下面可查看定价，库存，交付和生命周期等信息

[>>TE Connectivity\(泰科\)](#)