

REVISIONS				
P	LTR	DESCRIPTION	DATE	APVD
	B	REV PER ECO 19-015129	10-4-19	CT RL

- 1 . ITEMS PACKAGED IN POLY BAG & LABELED WITH AMP PART NUMBER AND DATE CODE.
- 2 KEYING POST
 MAT'L: ZINC ALLOY PER ASTM B 86
 FINISH: ELECTROLESS NICKEL PER MIL-C-26074
- KEYING PLATE
 MAT'L: ALUMINUM ALLOY PER AMS-QQ-A-250
 FINISH: BLUE ANODIZED PER MIL-A-8625
- KEYING SCREWS
 MAT'L: PASSIVATED STAINLESS STEEL

THIS DRAWING IS UNPUBLISHED.

ALL RIGHTS RESERVED.

© COPYRIGHT - TE Connectivity Ltd.

448012-1
 PART NUMBER

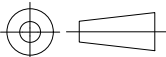
DIMENSIONS: INCHES	DWN	W.P.LEUFERT	7-23-91	MATERIAL	-	FINISH	-
	CHK	S.E.WRIGHT	7-24-91	 TE Connectivity			
TOLERANCES UNLESS OTHERWISE SPECIFIED:	APVD	S.E.WRIGHT	7-24-91				
0 PLC ± -	PRODUCT SPEC			NAME			
1 PLC ± -	-			KEYING KIT, ARINC 600, PLUG			
2 PLC ± -	APPLICATION SPEC			-			
3 PLC ± -	-			SIZE	CAGE CODE	DRAWING NO	RESTRICTED TO
4 PLC ± -	-			A4	00779	C-448012	-
ANGLES ± -	WEIGHT			SCALE			
	0.000000			1:1			
CUSTOMER DRAWING				SHEET		1 OF 1	
						REV B	

单击下面可查看定价，库存，交付和生命周期等信息

[>>TE Connectivity\(泰科\)](#)