

THIS DRAWING IS UNPUBLISHED. RELEASED FOR PUBLICATION ,19 .  
 © COPYRIGHT 19 BY AMP INCORPORATED. ALL INTERNATIONAL RIGHTS RESERVED.

LOC		DIST		P		F		REVISIONS		DATE	APPD
G	14							ZONE	LTR	DESCRIPTION	
								C		REV PER 063A-0124-02	06MAR02 JS MS

**METRIC**  
 DIMENSIONS LISTED IN mm [ INCHES ]

<b>AMP</b> WIRE RANGE	<b>UL</b> E13288 Listed
26-22 AWG STRANDED	NOT LISTED
<b>SP</b> LR7189 Certified	MILITARY P/N AND CLASS
NOT CERTIFIED	NOT APPLICABLE

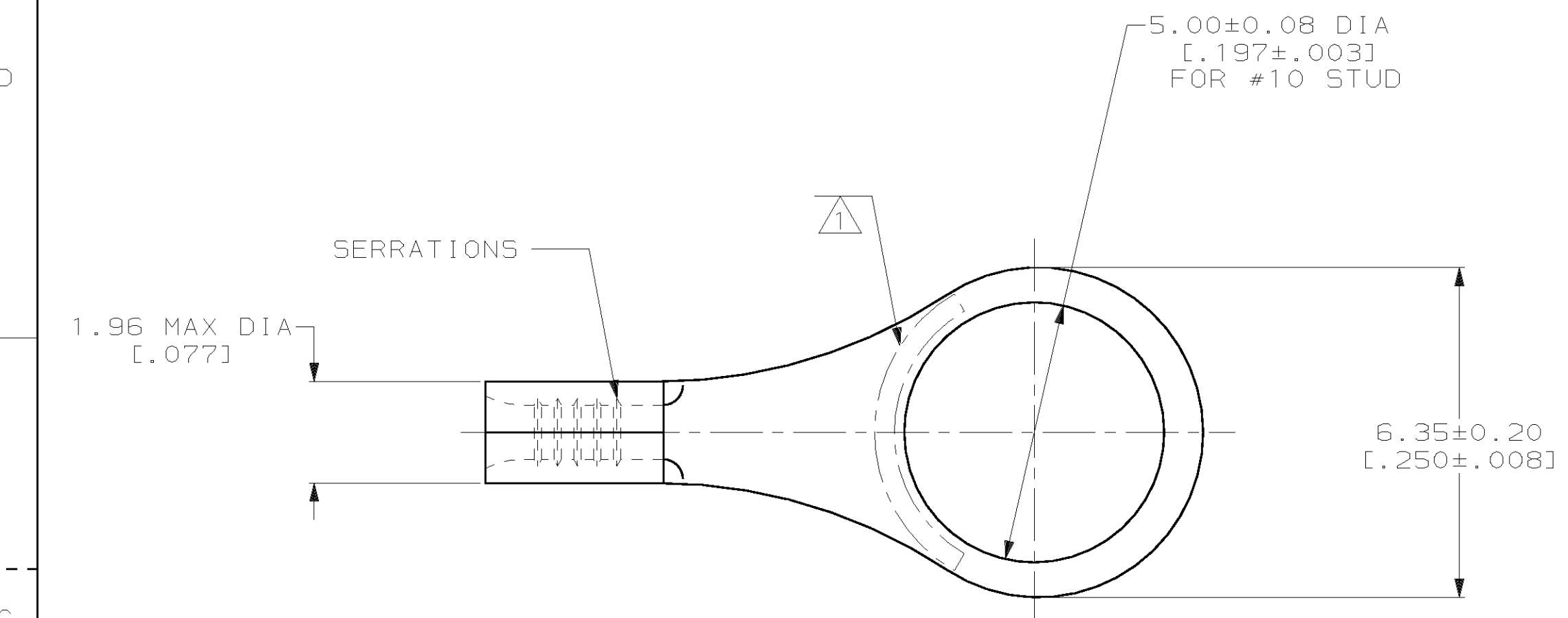

- ① STAMP AMP APPROX AS SHOWN
- ② 0.00254 [.000100] MIN TIN PER ASTM B-545
- ③ CLEANED, UNPLATED

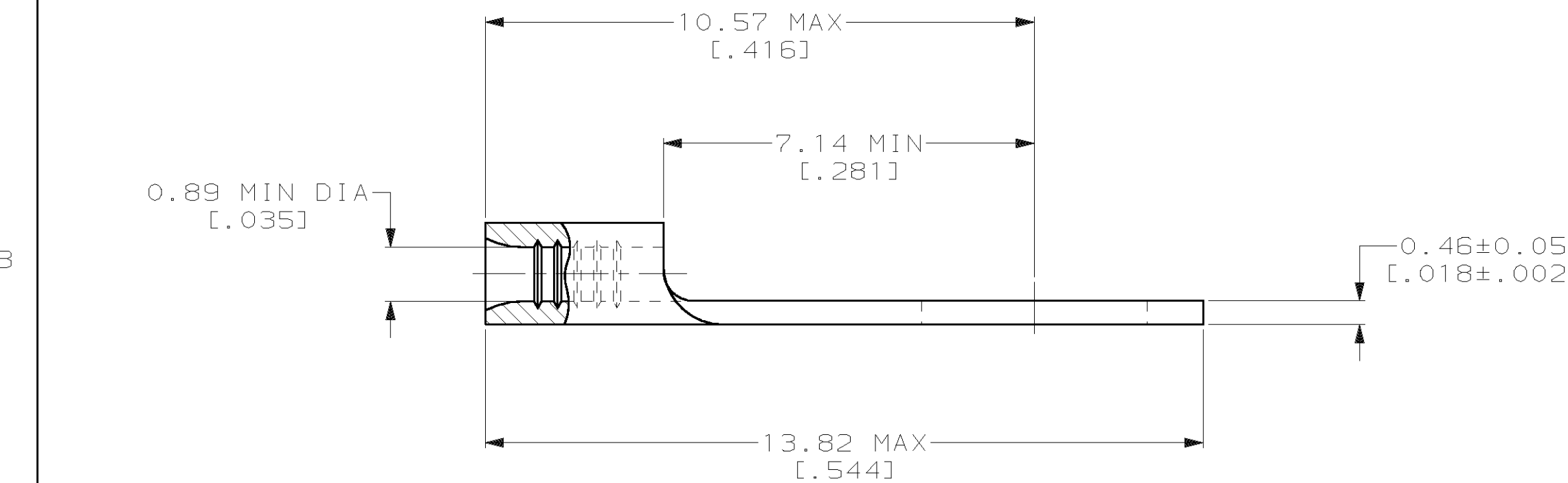

③	32860-1
②	32860
FINISH	PART NO

**AMP INCORPORATED**  
**CUSTOMER SERVICE SYSTEMS**

FOR ADDITIONAL PRODUCT INFORMATION OR COPIES OF DRAWINGS AND TECHNICAL DOCUMENTS	PRODUCT INFORMATION CENTER 1-800-522-6752
FOR APPLICATION TOOLING INFORMATION	TOOLING ASSISTANCE CENTER 1-800-722-1111
FOR ORDER ENTRY	1-800-526-5142

MAX RECOMMENDED OPERATING TEMPERATURE:  
 170°C MAX

VOLTAGE RATING:  
 NOT APPLICABLE

WIRE CROSS SECTIONAL AREA RANGE:  
 0.1-0.41mm<sup>2</sup> [202-810] CIR MILS  
 STRANDED

THIS DRAWING IS A CONTROLLED DOCUMENT FOR AMP INCORPORATED. IT IS SUBJECT TO CHANGE AND THE CONTROLLING ENGINEERING ORGANIZATION SHOULD BE CONTACTED FOR THE LATEST REVISION.

DO NOT SCALE PRINT. UNLESS SPECIFIED DIMENSIONS IN mm [INCHES] TOLERANCES ON:

2 PLC DEC ± -  
 3 PLC DEC ± -  
 ANGLES ± -

MATERIAL  
 COPPER PER ASTM B-152 ANNEALED

FINISH  
 -  
 -  
 -

DR 2-2-93 TA BRINKMAN  
 CHK 2-2-93 DA PATTERSON  
 APPD 2-2-93 DE MILLER  
 APPD 2-2-93 JL MECKLEY  
 PRODUCT SPEC -  
 APPLICATION SPEC -  
 WEIGHT -

**AMP** AMP Incorporated  
 Harrisburg, PA 17105-3608

NAME  
 TERMINAL, RING TONGUE, BUDGET

SIZE	CAGE CODE	DRAWING NO
C	00779	C-32860
SCALE	10:1	SHEET 1 OF 1

单击下面可查看定价，库存，交付和生命周期等信息

[>>TE Connectivity\(泰科\)](#)