

THIS DRAWING IS UNPUBLISHED.

RELEASED FOR PUBLICATION

REVISIONS

© COPYRIGHT - TE Connectivity Ltd.

ALL RIGHTS RESERVED.

P	LTR	DESCRIPTION	DATE	DWN	APVD
	A2	REVISED PER ECR-19-002313	13FEB2019	ED	RS

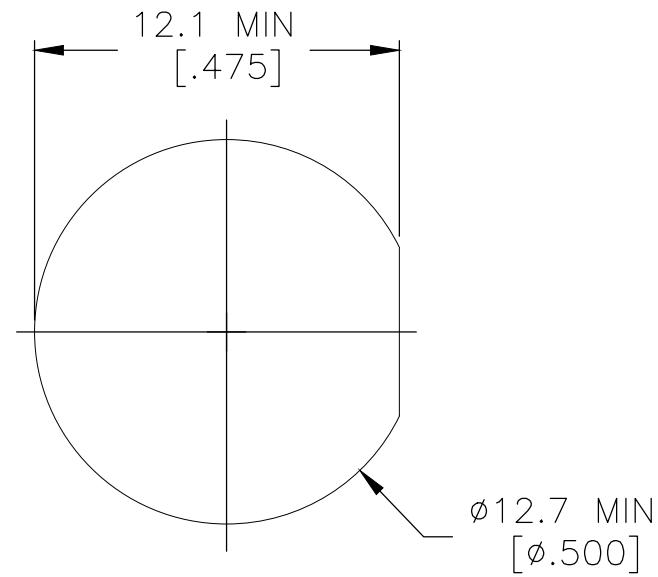
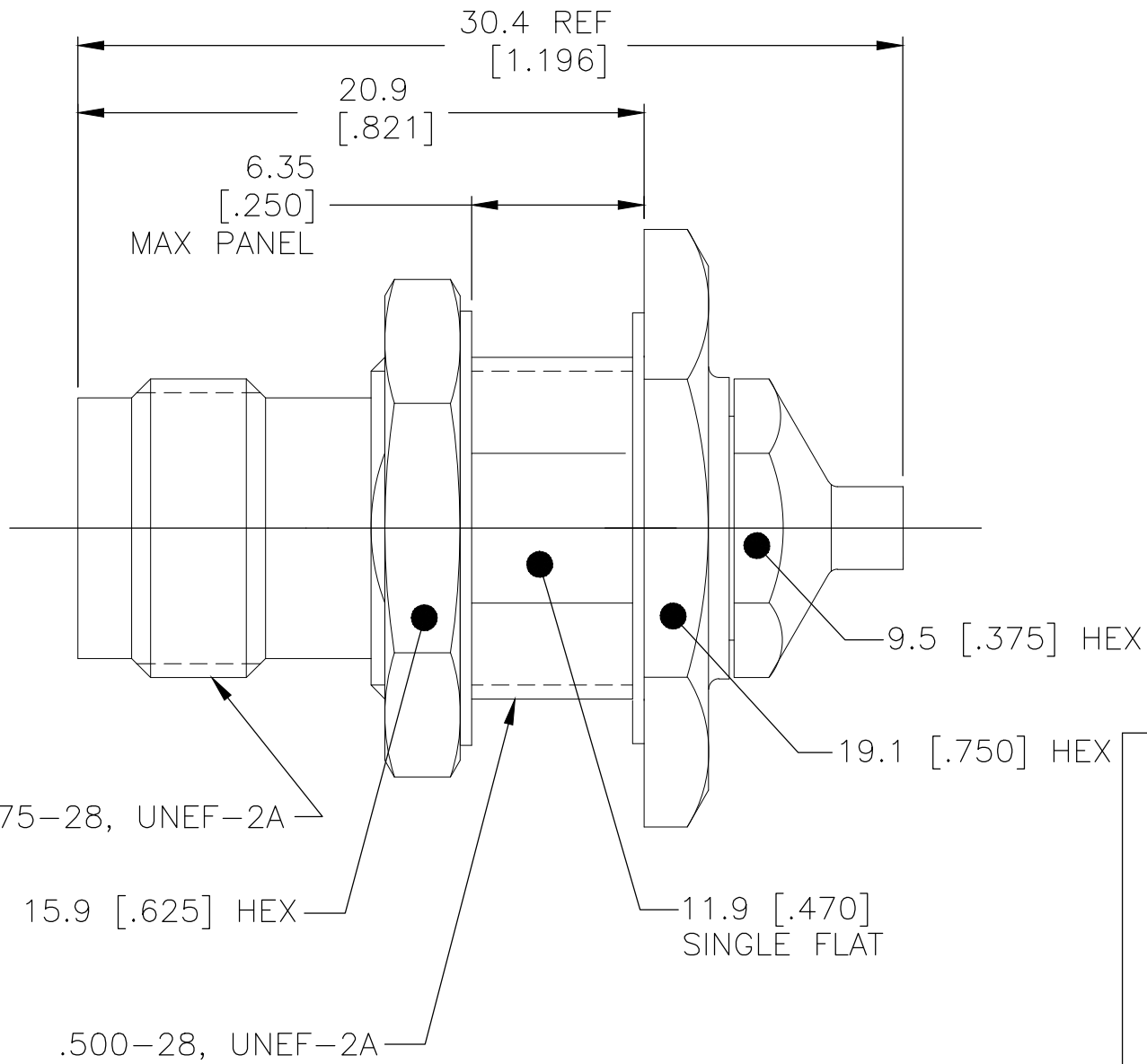

RECOMMENDED MOUNTING HOLE

1. SEE INSTRUCTION SHEET 408-8205.

COMPONENT	MATERIAL	FINISH
REAR HOUSING MOUNTING NUT LOCKWASHER	STAINLESS STEEL PER ASTM-A484 AND ASTM-A582	PASSIVATE PER QQ-P-35
FRONT HOUSING	BRASS PER ASTM-B-16	GOLD PLATE PER ASTM-B488
DIELECTRIC	TFE FLUOROCARBON PER ASTM-D-1710	N/A
CENTER CONTACT	BERYLLIUM COPPER PER ASTM-B-196 OR ASTM-B-197	GOLD PLATE PER ASTM-B488
GASKET	SILICONE RUBBER PER ZZ-R-765	N/A

DESIGNED FOR USE WITH .141" S.R.	
CABLE ENTRY DIAMETER MINIMUM	
HOUSING	3.61 [.142]
CONTACT	1.07 [.042]

THIS DRAWING IS A CONTROLLED DOCUMENT.		DWN R.M.K. 3/5/70	TE Connectivity NAME TNC STRAIGHT BULKHEAD CABLE JACK DIRECT SOLDER VERSION					
DIMENSIONS: mm [INCHES]		CHK B.W.C. 6/29/70				APVD T.A.R. 6/29/70	SIZE	CAGE CODE
TOLERANCES UNLESS OTHERWISE SPECIFIED:		PRODUCT SPEC				DRAWING NO	RESTRICTED TO	
0 PLC ± - 1 PLC ± 0.13 [.005] 2 PLC ± - 3 PLC ± - 4 PLC ± - ANGLES ± 1° FINISH		APPLICATION SPEC				00779	—	
MATERIAL		WEIGHT 0.000000		G-1057676				
		CUSTOMER DRAWING		SCALE 4:1	SHEET 1 OF 1			
				REV A2				

单击下面可查看定价，库存，交付和生命周期等信息

[>>TE Connectivity\(泰科\)](#)