

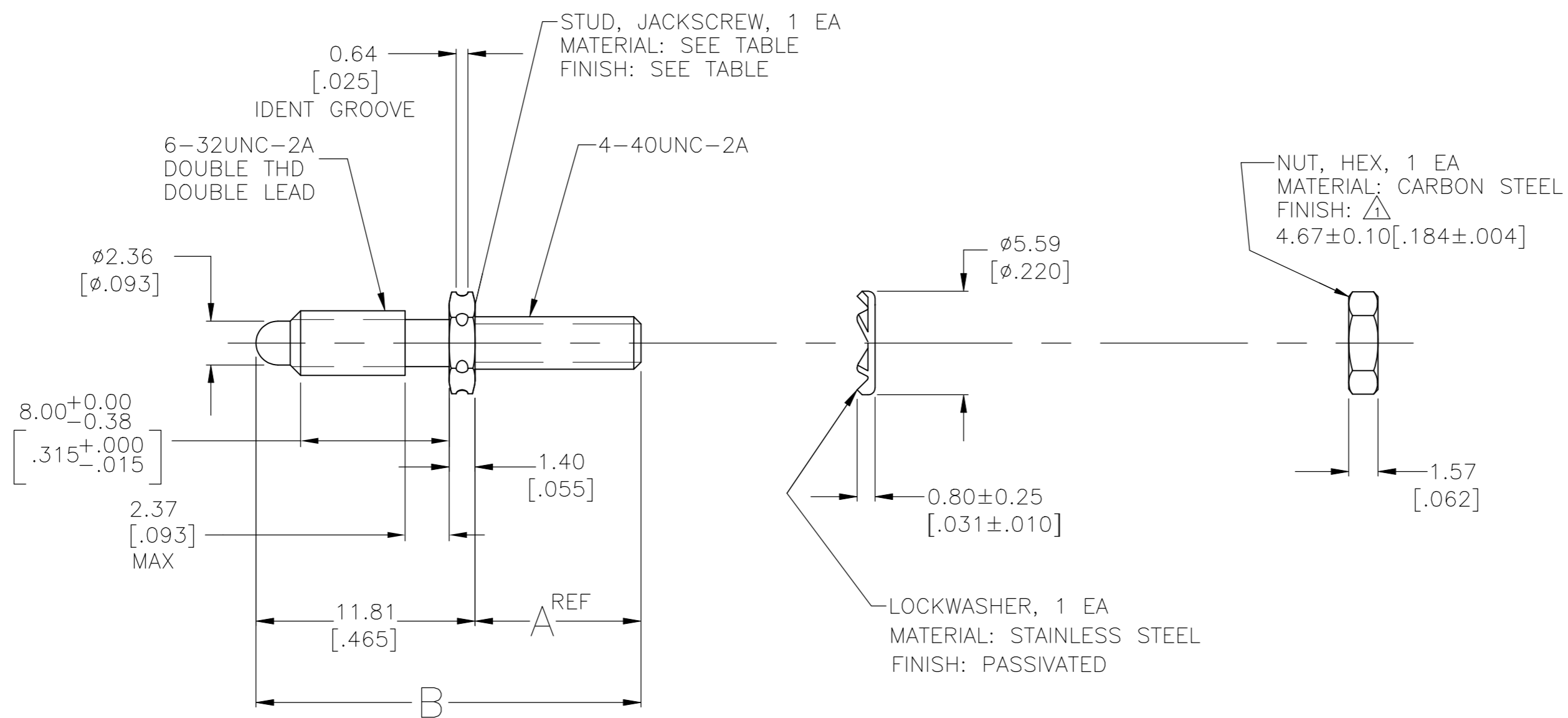

THIS DRAWING IS UNPUBLISHED. RELEASED FOR PUBLICATION
 © COPYRIGHT - TE Connectivity Ltd. ALL RIGHTS RESERVED.

REVISIONS					
P	LTR	DESCRIPTION	DATE	DWN	APVD
	AG	REVISED PER ECO-10-021995	12JAN11	HMR	MG
	AH	REVISED PER ECO-18-005806	24APR2018	RS	MZ

 ZINC PLATE

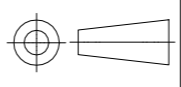

	-	STAINLESS STL	20.62 [.812]	8.81 [.347]	1-200874-2
	-	STAINLESS STL	23.80 [.937]	11.99 [.472]	200874-3
	SUPERCEDED TO 200874-1	ZINC CARBON STEEL	20.62 [.812]	8.81 [.347]	200874-2
	SUPERCEDED TO 1-200874-2	- STAINLESS STL	20.62 [.812]	8.81 [.347]	200874-1
	FINISH	MATERIAL	B	A	PART NUMBER
JACKSCREW STUD					

THIS DRAWING IS A CONTROLLED DOCUMENT.		DWN C.OBERMAN 02/25/92	 TE Connectivity Ltd.		
DIMENSIONS: mm [INCHES]		CHK R.STONE 2-28-92			
		TOLERANCES UNLESS OTHERWISE SPECIFIED:	NAME		
MATERIAL SEE CALLOUT		FINISH SEE CALLOUT	JACKSCREW KIT, UNASSEMBLED, STUD, FIXED, M SERIES		
		APVD -	SIZE A2	CAGE CODE 00779	DRAWING NO C=200874
		PRODUCT SPEC -	RESTRICTED TO -		
		APPLICATION SPEC -	SCALE 4:1	SHEET 1 of 1	REV AH
		ANGLES ± -	CUSTOMER DRAWING		

单击下面可查看定价，库存，交付和生命周期等信息

[>>TE Connectivity\(泰科\)](#)