

THIS DRAWING IS UNPUBLISHED. RELEASED FOR PUBLICATION
 © COPYRIGHT - By - ALL RIGHTS RESERVED.

LOC		DIST		REVISIONS					
AJ		16		P	LTR	DESCRIPTION	DATE	DWN	APVD
				N2		REVISED PER ECO-11-005030	11MAR11	RK	HMR

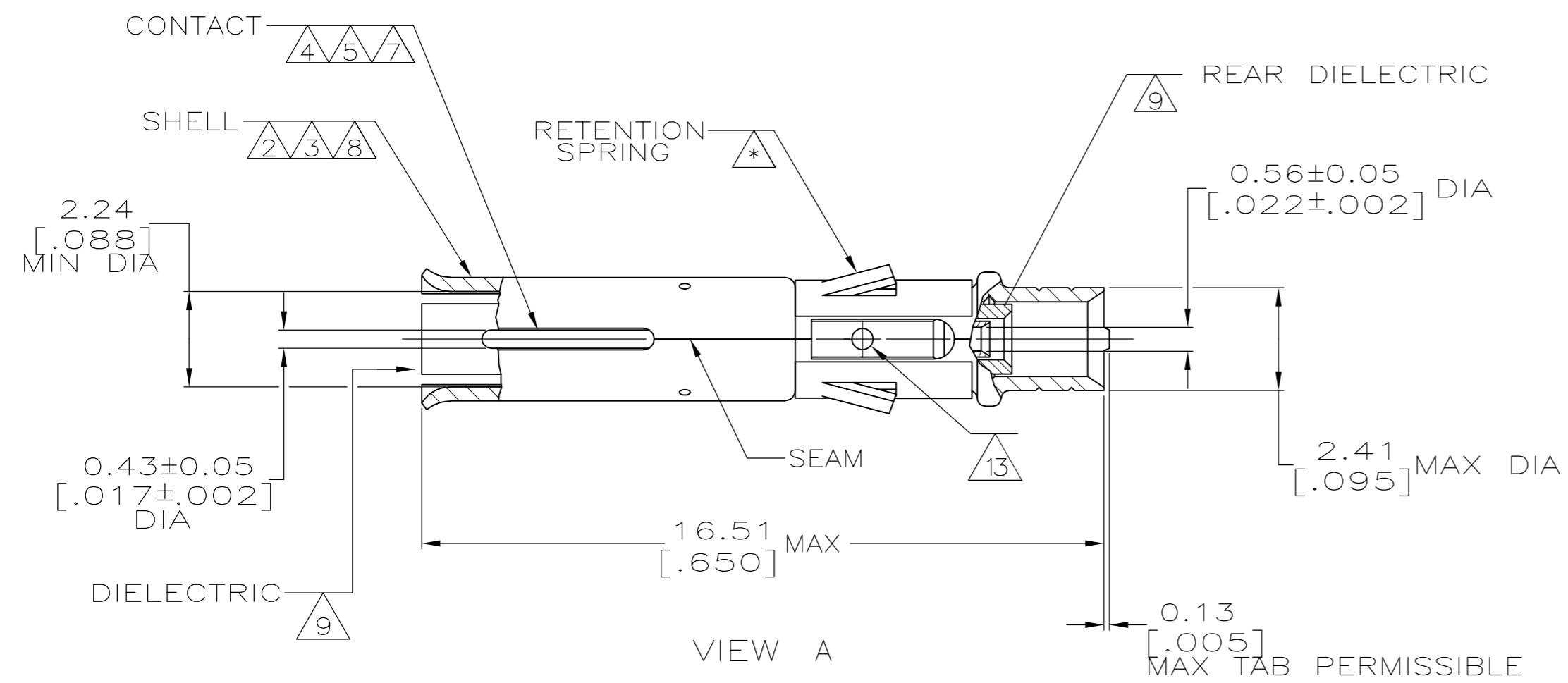

VIEW A

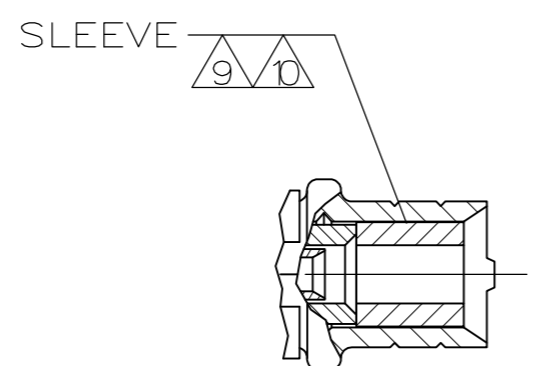

VIEW B

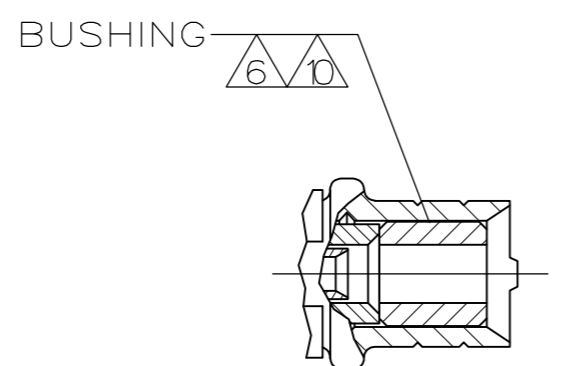

VIEW C

1. FOR CABLE SELECTION, FERRULE AND HANDTOOL PART NUMBERS, SEE I.S. 2024-2

- △2 GOLD PLATE PER MIL-G-45204,.000027 MINIMUM THICKNESS
- △3 GOLD PLATE PER MIL-G-45204,.000045 MINIMUM THICKNESS
- △4 GOLD PLATE PER MIL-G-45204,.000030 MINIMUM THICKNESS
- △5 GOLD PLATE PER MIL-G-45204,.000050 MINIMUM THICKNESS
- △6 TIN PLATE PER MIL-T-10272
- △7 BRASS PER QQ-B-626
- △8 BRASS PER MIL-C-50
- △9 POLYPROPYLENE,GENERAL PURPOSE
- △10 BRASS PER ASTM-B-135
- △11 STAINLESS STEEL,SPRING TEMPER PER QQ-S-766
- △12 PTFE PER MIL-P-19468
- △13 SIGHT HOLE VISIBLE THROUGH THE PORT SLOT ON RETENTION SPRING
- △14 OBSOLETE PARTS: OBSOLETE CIS STREAMLINING PER D.RENAUD/D.SINISI

△13	OBSOLETE	A	△2 △4	△7 △8 △9 △11	1-51565-5
△14	OBSOLETE	A	△2 △4	△7 △8 △9 △11	1-51565-4
	OBSOLETE	B	△3 △5	△7 △8 △9 △11 △12	1-51565-3
	OBSOLETE	C	△3 △5 △6	△7 △8 △9 △10 △11	51565-6
	OBSOLETE	B	△3 △5	△7 △8 △9 △11	51565-5
	OBSOLETE	A	△3 △5	△7 △8 △9 △11	51565-4
	OBSOLETE	C	△2 △4 △6	△7 △8 △9 △10 △11	51565-3
	OBSOLETE	B	△2 △4	△7 △8 △9 △11	51565-2
	OBSOLETE	A	△2 △4	△7 △8 △9 △11	51565-1
		VIEW	FINISH	MATERIAL	PART NUMBER

THIS DRAWING IS A CONTROLLED DOCUMENT. DWN 4-23-91 B. WERNER
 CHK 5-3-91 D. DOYE
 APVD -
 PRODUCT SPEC -
 APPLICATION SPEC -
 WEIGHT -

STE TE Connectivity

SOCKET ASSEMBLY, SERIES SUBMINIATURE

SIZE A2 CAGE CODE 00779 DRAWING NO C=51565 RESTRICTED TO -
 SCALE 8:1 SHEET 1 of 1 REV N2

DIMENSIONS: INCHES TOLERANCES UNLESS OTHERWISE SPECIFIED:
 0 PLC ± -
 1 PLC ± -
 2 PLC ± -
 3 PLC ± -
 4 PLC ± -
 ANGLES ± -
 MATERIAL SEE TABLE FINISH SEE TABLE

CUSTOMER DRAWING

单击下面可查看定价，库存，交付和生命周期等信息

[>>TE Connectivity\(泰科\)](#)