

THIS DRAWING IS UNPUBLISHED. RELEASED FOR PUBLICATION
 © COPYRIGHT - By - ALL RIGHTS RESERVED.

LOC	DIST	REVISIONS			
P	LTR	DESCRIPTION	DATE	DWN	APVD
AF	50	E1	REVISE PER ECR-14-007779	28MAY2014	GRZ JL

- CONTINUOUS STRIP ON REEL.
- CRIMP WIDTH 1.07 [.042], F (AMPLIVAR TYPE)
 CRIMP HEIGHT ± 0.05 [.002] = (TOTAL CMA + 1,600) / 74,000
 GENERAL APPLICATION GUIDELINES MUST BE FOLLOWED AS SPECIFIED IN CATALOG #82221
 FOR APPLICATOR INFO CALL, 1-800-722-1111
 FOR PRODUCT INFO CALL, 1-800-522-6752

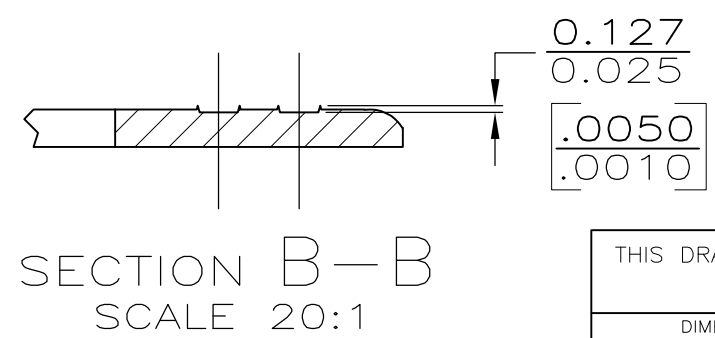
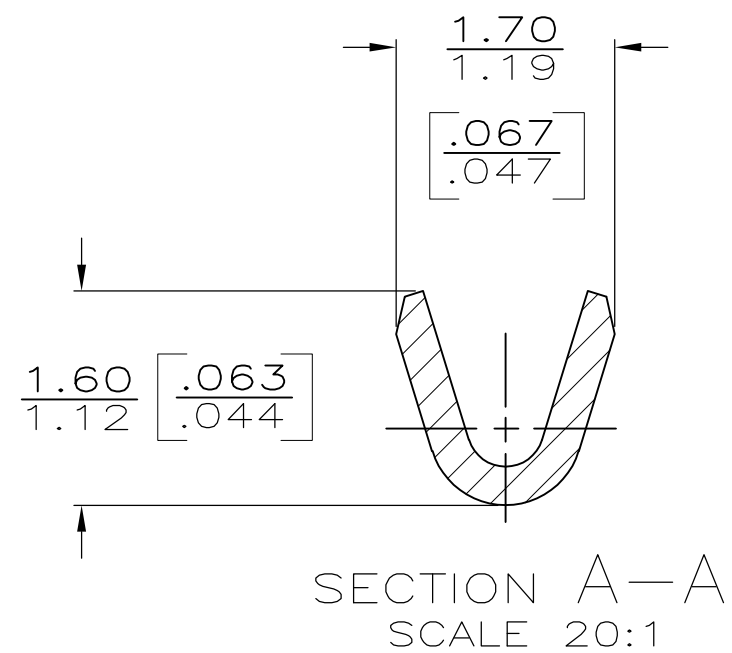
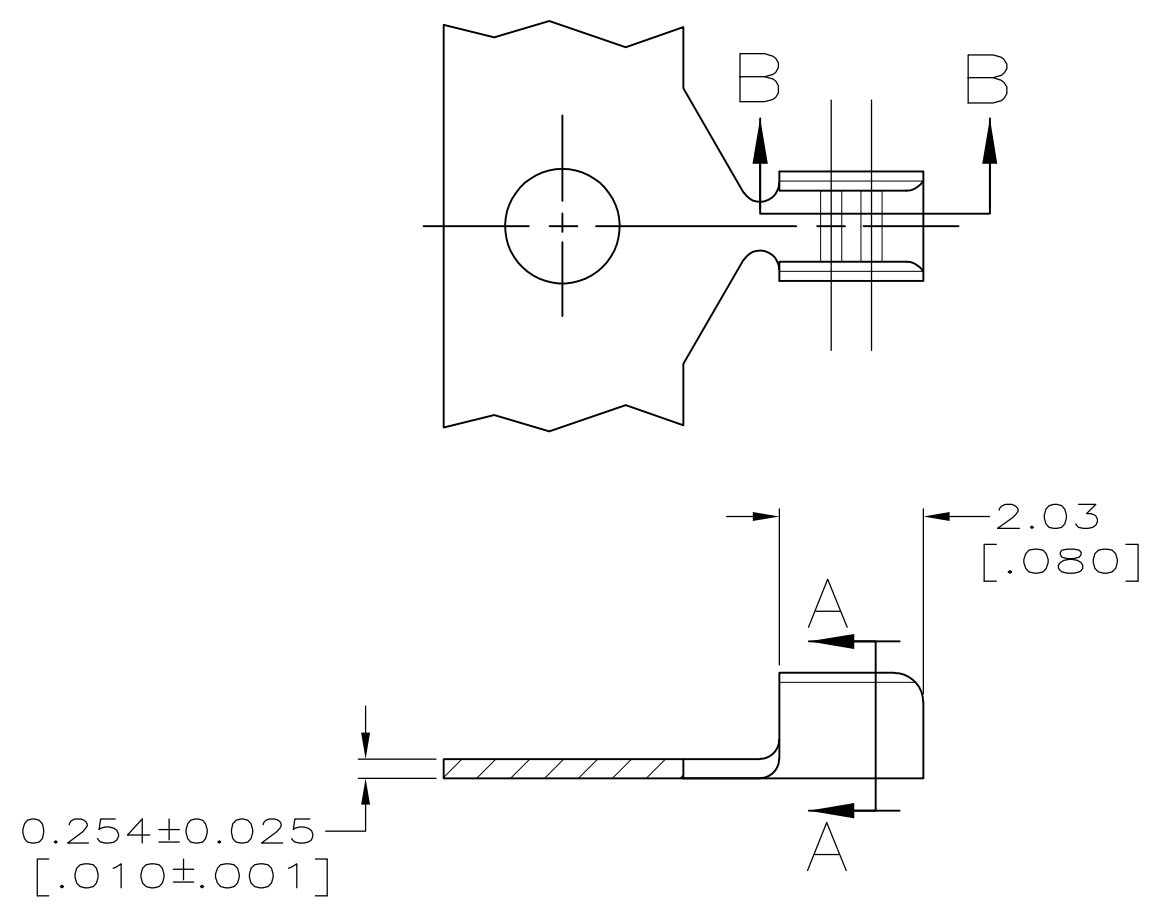

OBSOLETE

TIN PLATE	100-300 CMA	63621-2
		63621-1
FINISH	WIRE RANGE	PART NUMBER

THIS DRAWING IS A CONTROLLED DOCUMENT.		DWN P FORTNEY 8/8/91	STE TE Connectivity			
DIMENSIONS: INCHES		CHK MS FEHER 8/8/91				
TOLERANCES UNLESS OTHERWISE SPECIFIED:		APVD - 8/8/91 D SCHWENK	NAME SPLICE,AMPLIVAR, SUB-MINIATURE			
0 PLC ± -		PRODUCT SPEC - 8/8/91 R WEAVILL				
1 PLC ± -		APPLICATION SPEC -	SIZE	CAGE CODE	DRAWING NO	RESTRICTED TO
2 PLC ± 0.25 [.010]		WEIGHT -	A3	00779	C-63621	-
3 PLC ± -		CUSTOMER DRAWING				
4 PLC ± -		SCALE	10:1	SHEET	1 OF 1	REV
ANGLES ± -		E1				
MATERIAL BRASS		FINISH SEE TABLE				

单击下面可查看定价，库存，交付和生命周期等信息

[>>TE Connectivity\(泰科\)](#)