

- 1 POSITION TOLERANCE APPLIES AT CONTACT TIP.
- 2 POSITION NUMBERS SHOWN FOR REFERENCE ONLY.
- 3 MATERIAL:
HOUSING - POLYPHTHALAMIDE, BLACK, UL 94-V0 RATED.
SHELL - CARBON STEEL.
CONTACTS - PHOSPHOR BRONZE.
BRACKET - ZINC.
- 4 FINISH:
SHELL - 5.08µm [.000200] MIN NICKEL OVER 1.27µm [.000050] MIN COPPER.
BRACKET - 3.81µm [.000150] MIN NICKEL OVER 5.08µm [.000200] MIN COPPER.
CONTACTS - EITHER 0.76µm [.000030] MIN GOLD PLATE OR GOLD FLASH OVER PALLADIUM NICKEL PLATE, 0.76µm [.000030] MIN TOTAL, FOR A LENGTH OF 0.64 [.025] MIN, 0.13 [.005] MAX FROM MATING END, 1.27µm [.000050] MIN TIN ON OPPOSITE END FOR A LENGTH OF 7.49 [.295] MIN, BOTH OVER 1.27µm [.000050] MIN NICKEL.
- 5 PC BOARD HOLE RECOMMENDATIONS:
A. HOLES SHOULD BE DRILLED WITH A 0.701 [.0276] DRILL.
B. PC BOARD PLATING TO BE 7.62µm [.000300] MIN TIN OVER 0.025-0.038 [.0010-.0015] COPPER.
C. RECOMMENDED HOLE SIZE AFTER TIN PLATING IS 0.56-0.66 [.022-.026].

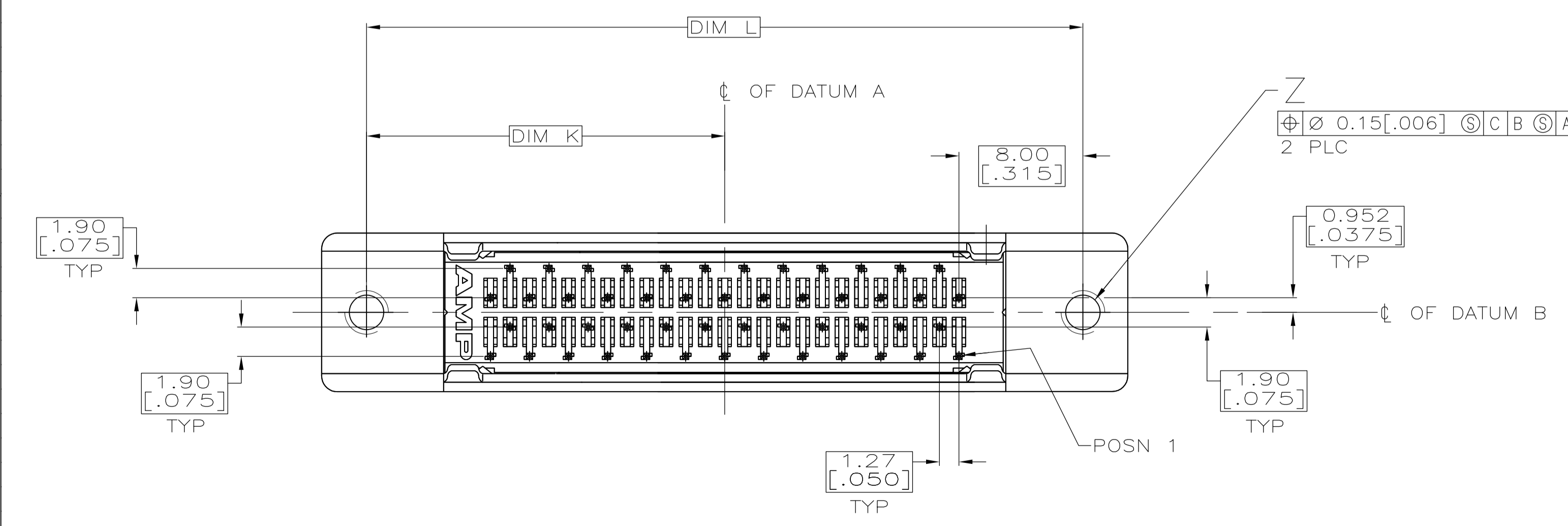

PER DETAIL X	3.07 DIA [.121]	63.88 [2.515]	41.91 [1.650]	46.13 [1.816]	57.91 [2.280]	28.96 [1.140]	68	1-5786557-1
PER DETAIL X	4-40 UNC-2B	84.20 [3.315]	62.23 [2.450]	66.45 [2.616]	78.23 [3.080]	39.12 [1.540]	100	5786557-9
PER DETAIL X	4-40 UNC-2B	63.88 [2.515]	41.91 [1.650]	46.13 [1.816]	57.91 [2.280]	28.96 [1.140]	68	5786557-7
PER DETAIL Y	4-40 UNC-2B	52.45 [2.065]	30.48 [1.200]	34.70 [1.366]	46.48 [1.830]	23.24 [.915]	50	5786557-5
RECOMMENDED PCB MTG DIMENSIONS	Z	R	P	N	L	K	NO OF POSN	PART NUMBER

COPYRIGHT 2005 TYCO ELECTRONICS CORP ALL RIGHTS RESERVED

THIS DRAWING IS A CONTROLLED DOCUMENT.

DIMENSIONS: mm [INCHES]	TOLERANCES UNLESS OTHERWISE SPECIFIED:	DIN G. ATTADIA - DOCKS	02-25-05
0 PLC ± -	1 PLC ± -	S. SHUFLEY	13DEC05
2 PLC ± 0.13 [.005]	3 PLC ± -	M. WALMSLEY	02-25-05
4 PLC ± -	ANGLES ± -	NAME	
MATERIAL	FINISH	APPROD	

RECEPTACLE ASSEMBLY, SHIELDED, VERTICAL, FLAT TOP, ACTION PIN FOR .125 TO .200 THICK BD, AMPLIMITE .050 SERIES

108-1228

114-40029

00779

5786557

CUSTOMER DRAWING SCALE 4:1 SHEET 1 OF 1 REV B

单击下面可查看定价，库存，交付和生命周期等信息

[>>TE Connectivity\(泰科\)](#)