

THIS DRAWING IS UNPUBLISHED. RELEASED FOR PUBLICATION JUNE ,2006.  
 © COPYRIGHT 2006 By - ALL RIGHTS RESERVED.

LOC	DIST	REVISIONS			
P	LTR	DESCRIPTION	DATE	DWN	APVD
E	B	B	ECR-05-013423	13DEC05	JMS FWK
		C	ECO-11-010168	17MAY2011	TITAN MARTIN

NOTES:

- 1 PACK IN ACCORDANCE WITH AMP SPEC 107-3275
- 2 100 TRAY PACK IN ACCORDANCE WITH AMP SPEC 107-3275
- 3 Au PLATING
- 4 Ni PLATING
- 5 Sn PLATING

6 ELECTRICAL CHARACTERISTICS  
 FREQUENCY RANGE: DC - 1 GHz  
 NOMINAL IMPEDANCE: 75 Ohms  
 INSULATION RESISTANCE: 5000 MOhms Min.  
 WORKING VOLTAGE: 500 Volts RMS at Sea Level  
 DIELECTRIC WITHSTAND VOLTAGE: 1500 Volts RMS Max  
 CONTACT RESISTANCE:  
 CENTRE CONTACT: 1.50 mOhms Max  
 OUTER CONTACT: 1.0 mOhms Max  
 VSWR @ xGHz: 1.5 MAX. @0.3 GHz  
 INSERTION LOSS xdb: 0.5 dB MAX. @0.3 GHZ

7 MECHANICAL CHARACTERISTICS  
 DURABILITY: 500 MATINGS

8 ENVIRONMENTAL CHARACTERISTICS  
 OPERATING TEMPERATURE: -40 to +60 DegC

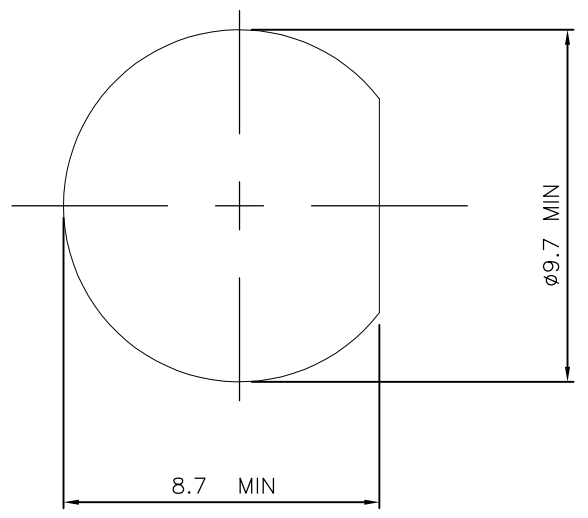
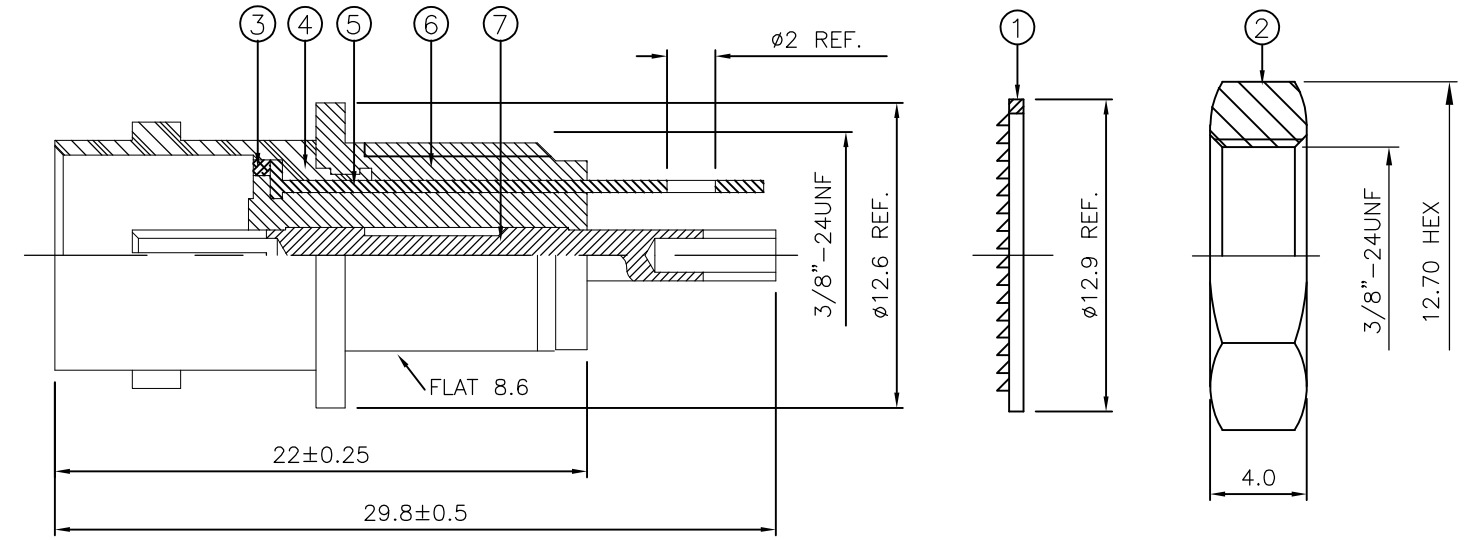

MOUNTING HOLE

QTY	QTY PER ASSY	MATERIAL	DESCRIPTION	ITEM
1	1	BRASS	CENTER CONTACT	7
1	1	ABS	BODY II	6
1	1	BRASS	GROUNDING TAB	5
1	1	BRASS	BODY I	4
1	1	BRASS	WASHER	3
1	1	BRASS	NUT	2
1	1	STEEL	WASHER	1
6--0	1--0	MATERIAL	DESCRIPTION	ITEM

THIS DRAWING IS A CONTROLLED DOCUMENT.		DWN J.SANDWELL 14JUN06	<b>STE</b> TE Connectivity	
DIMENSIONS: mm		CHK S.PARLOW 14JUN06		
TOLERANCES UNLESS OTHERWISE SPECIFIED:		APVD F.WHEELER-KING 14JUN06	NAME	
0 PLC ± -		PRODUCT SPEC	BNC INSULATED BULKHEAD JACK	
1 PLC ± 0.2		APPLICATION SPEC	FRONT MOUNT 75 OHM	
2 PLC ± 0.1		WEIGHT -	SIZE A3	CAGE CODE 00779
3 PLC ± 0.05		CUSTOMER DRAWING	DRAWING NO C-1478048	RESTRICTED TO -
4 PLC ± -			SCALE NTS	SHEET 1 OF 1
ANGLES ± 5°			REV C	
MATERIAL SEE TABLE				
FINISH SEE TABLE				

单击下面可查看定价，库存，交付和生命周期等信息

[>>TE Connectivity\(泰科\)](#)