

THIS DRAWING IS UNPUBLISHED. RELEASED FOR PUBLICATION
 © COPYRIGHT BY TYCO ELECTRONICS CORPORATION. ALL INTERNATIONAL RIGHTS RESERVED.

HOUSING MOUNTING NUT CLAMP NUT	STAINLESS STEEL PER ASTM-A484 AND ASTM- A582, TYPE 303	GOLD PLATE PER MIL-G-45204
DIELECTRIC	TFE FLUOROCARBON PER ASTM-D-1457	N/A
CENTER CONTACT	BERYLLIUM COPPER PER ASTM-B-196 OR ASTM-B-197, ALLOY C17300, CONDITION H	GOLD PLATE PER MIL-G-45204
SHRINK TUBING	HEAT SHRINKABLE POLYOLEFIN COMPOUND MIL-I-23053/4	N/A
CRIMP SLEEVE	COPPER OR BRASS ALLOY ROCKWELL F65 MAX	GOLD PLATE PER MIL-G-45204
COMPONENT	MATERIAL	FINISH

DESIGNED FOR USE WITH
RG174/U,179,187,188,& 316

CABLE ENTRY DIAMETER
MINIMUM

SLEEVE	.067
CONTACT	.024
DIELECTRIC	.066

LOC	DIST	REVISIONS			
P	LTR	DESCRIPTION	DATE	DWN	APVD
	A	RELEASE	11SEP08	PY	DW

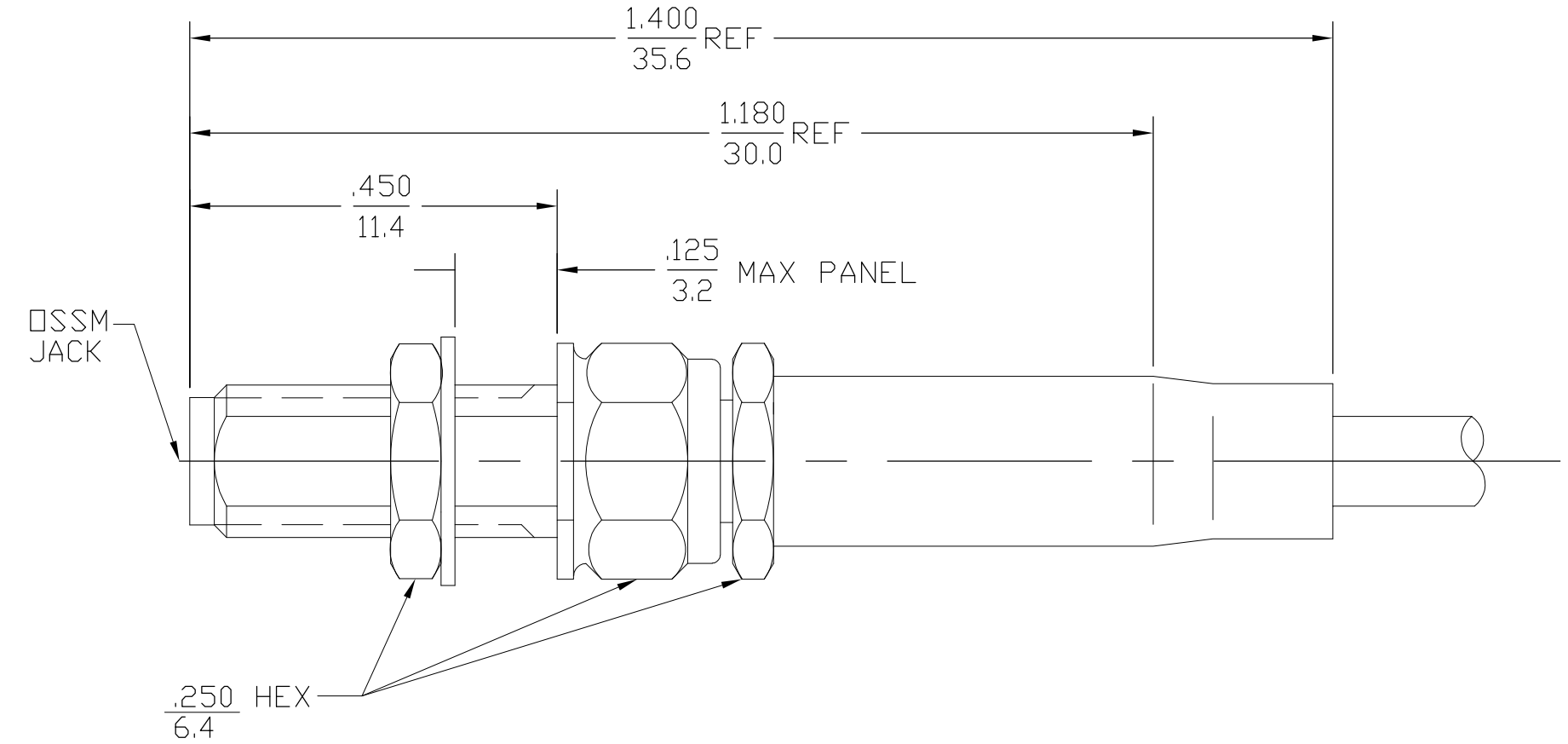
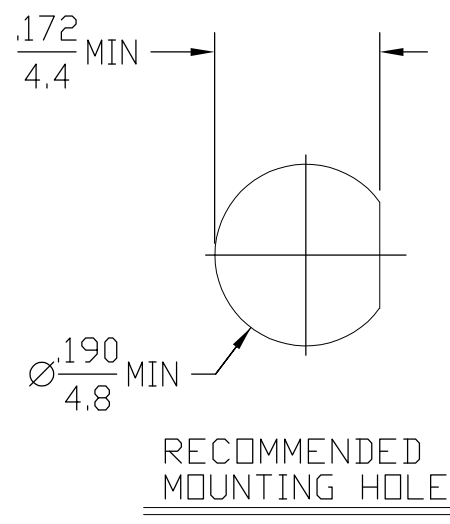

ELECTRICAL	MECHANICAL	ENVIRONMENTAL
Nominal Impedance (Ohms) <u>50</u>	Interface Dimensions MIL-STD-348A, Fig. 319-2	TEMPERATURE RATING <u>-65°C TO +165°C</u>
Frequency Range (GHz) DC to max operating frequency of cable	Recommended Mating Torque <u>5 In. Lbs.</u>	Vibration MIL-STD-202, Method 204, Condition D
Volt Rating (VRMS MAX) @ Sea Level <u>250</u>	Mating Characteristics: Insertion (MAX Lbs) <u>3</u>	Shock MIL-STD-202, Method 213, Condition I
VSWR <u>1.07+.015f</u> (f in GHz)	Withdrawal (MIN Oz) <u>1</u>	Thermal Shock MIL-STD-202, Method 107, Condition B, EXCEPT HIGH TEMP <u>-85°C</u>
Insertion Loss (dB MAX) <u>.04 √fGHz</u>	Force to Engage and Disengage (In-Lbs MAX) <u>2.0</u>	Moisture Resistance MIL-STD-202, Method 106
RF Leakage (dB MIN) <u>-60</u>	Center Contact Captivation Axial (Lbs) <u>6.0</u>	Corrosion - MIL-STD-202, Method 101, Condition B, 5% salt spray
Corona, 70,000 Ft (VRMS MIN) <u>190</u>	Radial (In-Oz) <u>N/A</u>	
Dielectric Withstanding Voltage (VRMS MIN) @ Sea Level <u>750</u>	Cable Retention Axial Force (Lbs) <u>20</u>	
Contact Resistance (Milliohms MAX) Center Contact <u>4.0</u>	Torque (In-Oz) <u>N/A</u>	
Outer Contact <u>2.0</u>	Weight (Grams) <u>2.4</u>	
Cable to Housing <u>0.5</u>		
RF High Potential @ Sea Level (VRMS MIN @ 5 MHz) <u>500</u>		
I.R.(Megohms MIN) <u>5,000</u>		

.XXX = in
XX.X = mm (REF)

1062253-1
PART NO.

THIS DRAWING IS A CONTROLLED DOCUMENT.		DWN P. YEAGER 11SEP2008	Tyco Electronics Corporation Harrisburg, PA 17105-3608	
DIMENSIONS: INCHES		CHK D. WILSON 11SEP08	NAME ASSM BULKHEAD FEEDTHRU CABLE JACK, CRIMP ATTACHMENT	
TOLERANCES UNLESS OTHERWISE SPECIFIED:		APVD D. WILSON 11SEP08	SIZE A2	
0 PLC ± -		PRODUCT SPEC	CAGE CODE 00779	DRAWING NO C=1062253
1 PLC ± -		APPLICATION SPEC	RESTRICTED TO	
2 PLC ± -		WEIGHT	SCALE 5:1	SHEET 1 of 1
3 PLC ± .005		CUSTOMER DRAWING	REV A	
4 PLC ± -				
ANGLES ± 1°				
MATERIAL SEE TABLE		FINISH SEE TABLE		

单击下面可查看定价，库存，交付和生命周期等信息

[>>TE Connectivity\(泰科\)](#)