

THIS DRAWING IS UNPUBLISHED. RELEASED FOR PUBLICATION JUNE ,2006.
 © COPYRIGHT 2006 BY TYCO ELECTRONICS CORPORATION. ALL RIGHTS RESERVED.

LOC	DIST	REVISIONS					
E	B	P	LTR	DESCRIPTION	DATE	DWN	APVD
		B		ECR-06-013423	22JUN06	JMS	FWK

NOTES:

- 1 PACK IN ACCORDANCE WITH AMP SPEC 107-3275
- 2 100 TRAY PACK IN ACCORDANCE WITH AMP SPEC 107-3275
- 3 Au PLATING
- 4 Ni PLATING
- 5 THIS ITEM MUST BE WHITE
- 6 HAND TOOL : 9-1478240-0
- 7 DIE SET : 9-1478245-0
- 8 ELECTRICAL CHARACTERISTICS
 FREQUENCY RANGE: DC - 2 GHz
 NOMINAL IMPEDANCE: 75 Ohm
 INSULATION RESISTANCE: 5000 MOhm
 WORKING VOLTAGE: 500 Volts RMS at Sea Level
 DIELECTRIC WITHSTAND VOLTAGE: 1500 Volts RMS Max
 CONTACT RESISTANCE:
 CENTRE CONTACT: 1.50 mOhm Max
 OUTER CONTACT: 0.20 mOhm Max
 VSWR @ 2GHz: 1.20:1 Max
 INSERTION LOSS dB @ x 2 GHz: 0.20 Max
- 9 MECHANICAL CHARACTERISTICS
 COUPLING RETENTION FORCE: N/A
 CABLE RETENTION FORCE: 85N Min
 MOUNT NUT RECOMMENDED TORQUE: 4N
 DURABILITY: 500 Cycles Min
- 10 ENVIRONMENTAL CHARACTERISTICS
 OPERATING TEMPERATURE: -65 to +165 DegC
- 11 FOR TECHNICAL DATA REFER TO YOUR LOCAL TYCO ELECTRONICS SALES OFFICE
- 12 ALL DIMENSIONS ARE NOMINAL FOR REFERENCE ONLY UNLESS OTHERWISE STATED

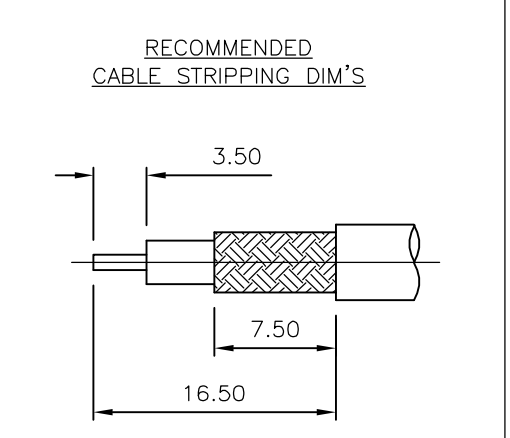
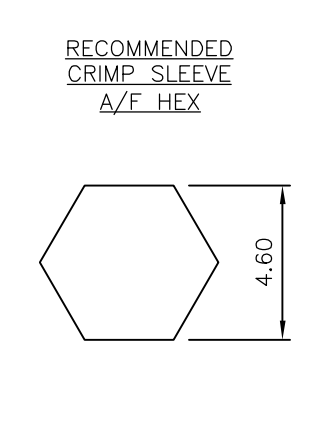
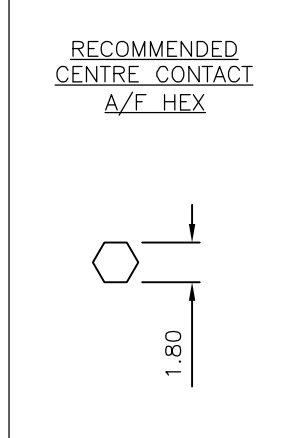
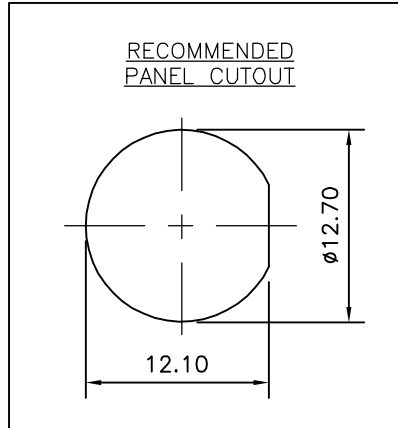
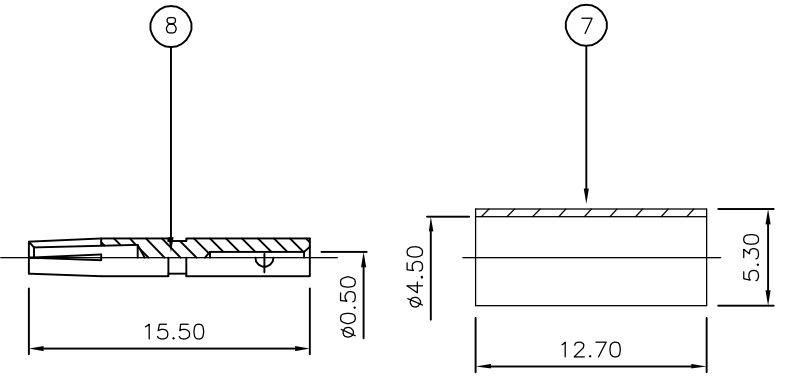
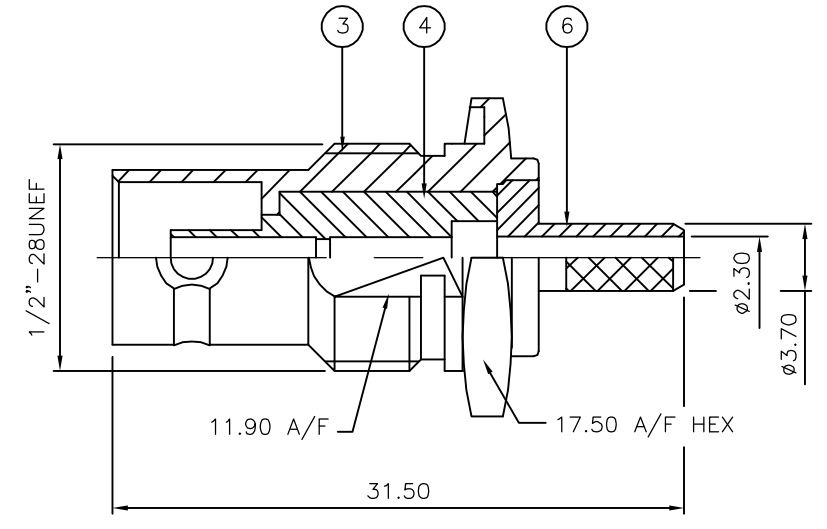
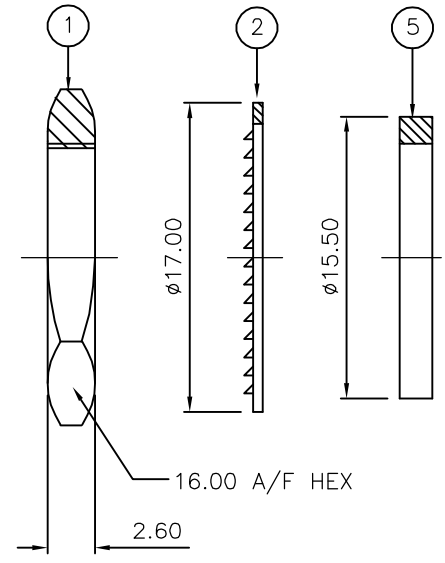

QTY	QTY	MATERIAL	DESCRIPTION	ITEM
1	1	BRASS	CONTACT	8
1	1	BRASS	FERRULE	7
1	1	BRASS	CHASSIS	6
1	1	SILICONE RUBBER	GASKET	5
1	1	PTFE	INSULATION	4
1	1	BRASS	BODY	3
1	1	STEEL	LOCKWASHER	2
1	1	BRASS	HEX NUT	1
6--0	1--0	MATERIAL	DESCRIPTION	ITEM

THIS DRAWING IS A CONTROLLED DOCUMENT.		DWN J.SANDWELL 22JUN06	Tyco Electronics Corporation Bideford EX39 4HE	
DIMENSIONS: mm		CHK S.PARLOW 22JUN06		
TOLERANCES UNLESS OTHERWISE SPECIFIED:		APVD F.WHEELER-KING 22JUN06	NAME BNC BULKHEAD JACK REAR MOUNT CRIMP 75 OHM BT3002	
0 PLC ± -		PRODUCT SPEC	SIZE A3 CAGE CODE 00779 DRAWING NO C-1478094 RESTRICTED TO -	
1 PLC ± -		APPLICATION SPEC	SCALE NTS SHEET 1 OF 1 REV B	
2 PLC ± -		WEIGHT -		
3 PLC ± -		CUSTOMER DRAWING		
4 PLC ± -				
FINISH -				
MATERIAL SEE TABLE				

单击下面可查看定价，库存，交付和生命周期等信息

[>>TE Connectivity\(泰科\)](#)